

Cornell University  
Library

The original of this book is in  
the Cornell University Library.

There are no known copyright restrictions in  
the United States on the use of the text.

<http://www.archive.org/details/cu31924075437594>

CORNELL UNIVERSITY LIBRARY



3 1924 075 437 594



THE  
EXCAVATION OF GEZER

VOL. III





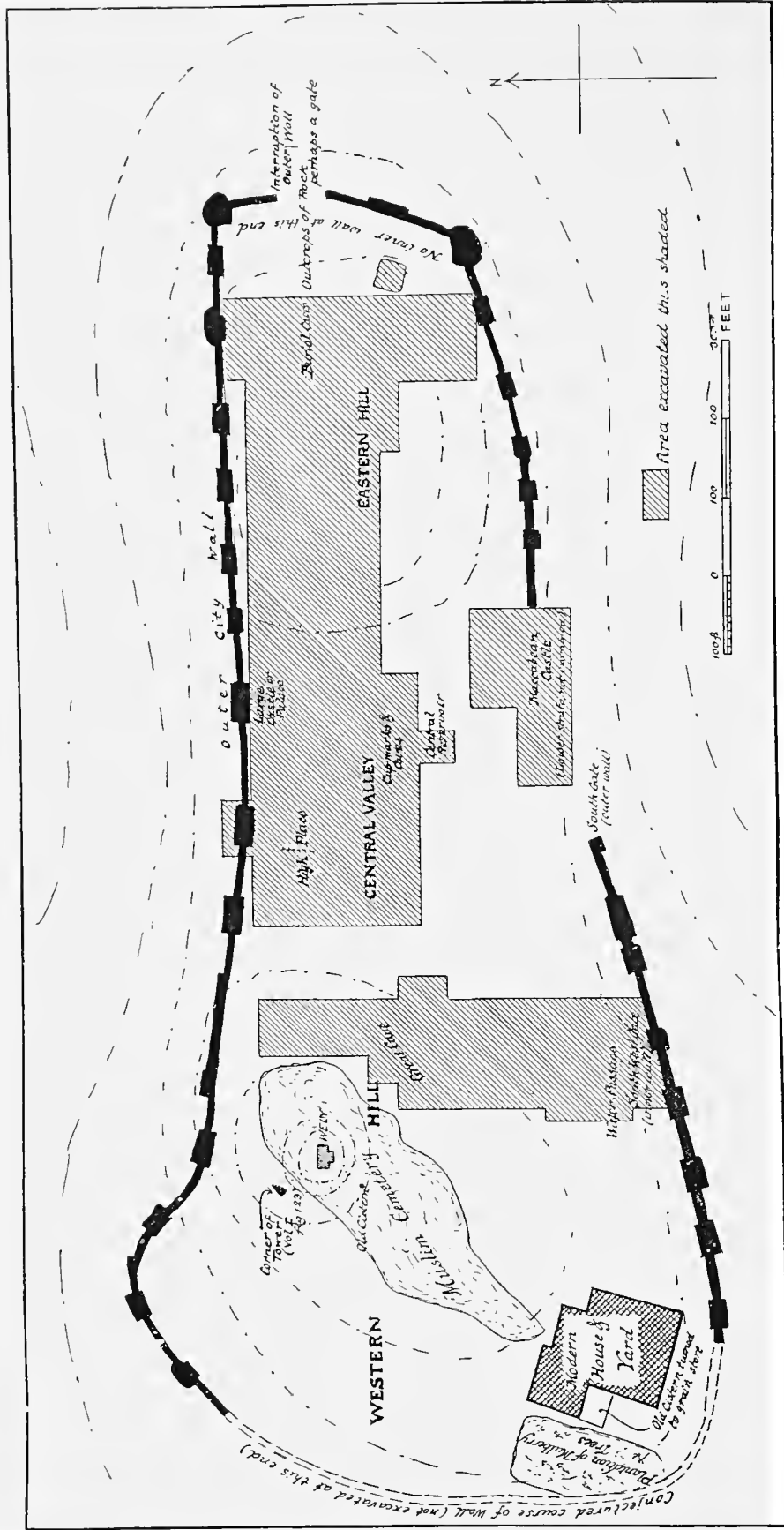

KEY PLAN OF THE EXCAVATIONS  
 Shewing their relation to the area of the city



THE  
EXCAVATION OF GEZER

1902—1905 AND 1907—1909

BY R. A. STEWART MACALISTER

M.A., F.S.A.,

PROFESSOR OF CELTIC ARCHAEOLOGY, UNIVERSITY COLLEGE, DUBLIN

WITH NUMEROUS ILLUSTRATIONS

IN TWO VOLUMES OF LETTERPRESS AND  
ONE VOLUME OF ILLUSTRATIONS

VOL. III

TWO HUNDRED AND TWENTY-SIX PLATES  
WITH INDEX

PUBLISHED FOR THE COMMITTEE OF THE PALESTINE EXPLORATION FUND

BY

JOHN MURRAY, ALBEMARLE STREET, LONDON, W.

1912

✓.



## INDEX TO PLATES

\*.\* The reference following the titles of the plates will help the reader to find the volume and page where the description of the objects illustrated will be found. Additional particulars elsewhere in the book regarding individual figures on the plate are referred to in the line below the title, in the form "17 (I. 126)," which means "for fig. 17 see vol. I. p. 126."

PLATE	PLATE
<p><i>Frontispiece</i> KEY PLAN OF THE EXCAVATION</p> <p>I-VII PLANS OF THE SUCCESSIVE STRATA OF BUILDINGS, WITH THE THREE INTERMEDIATE STRATA ON THE WESTERN HILL (I. 158-167) For the references on the plans see the list at the end of this Index.</p> <p>VIII PLAN OF THE SURROUNDINGS OF GEZER For sites and objects marked on this plan see the appropriate headings in the General Index.</p> <p>IX 1. HILLS SOUTH OF GEZER (I. 2) 2. THE "HAJAR IBRAHÎM" (I. 5, II. 50)</p> <p>X, XI BOUNDARY INSCRIPTIONS (I. 37-39) xi 3 (I. 40)</p> <p>XII MODERN FELLAHÎN OF THE DISTRICT (I. 64)</p> <p>XIII CAVE PLANS 1 (I. 109), 2 (I. 269), 3 (I. 271), 4 (I. 107), 5 (I. 270), 6 (I. 93), 7 (I. 76), 8 (I. 90), 9 (I. 109), 10 (I. 103), 11 (I. 143)</p> <p>XIV CAVE PLANS 1 (I. 82), 2 (I. 83), 3 (I. 84), 4-6 (I. 85), 7, 8 (I. 99), 9 (I. 86), 10 (I. 142), 11 (I. 143), rock surface (I. 86)</p>	<p>XV DETAILS OF CAVE 2 I [THE CREMATORIUM] (I. 74, 76)</p> <p>XVI CAVE 3 III AND ITS CONTENTS (I. 77, 78, II. 153), 9 (II. 149)</p> <p>XVII ROCK-SCARP WITH CUP-MARKS [ASSOCIATED WITH CAVE 4 I] (I. 78)</p> <p>XVIII CONTENTS OF CAVE 8 I (I. 81, 82 *) 20 (II. 166)</p> <p>XIX 1-9. CONTENTS OF CAVE 11 II (I. 84, II. 153) 10-24. CONTENTS OF WATER-PASSAGE (I. 264, 265) 25-28. CONTENTS OF CISTERN EAST OF TOMB NO. 11 (I. 273) 5 (II. 133), 9 (II. 150), 15 (II. 343)</p> <p>XX-XXII CONTENTS OF CAVE 15 I (I. 89-93, II. 176) xxii 5 (II. 135)</p> <p>XXIII 1-17. CONTENTS OF CAVE 15 I (<i>continued</i>) 18-21. CONTENTS OF CAVE 30 II a (I. 143) 22. PECULIAR LEDGE-HANDLE (II. 144)</p> <p>XXIV CONTENTS OF CISTERN IN CAVE 15 II (I. 94-96)</p> <p>XXV, XXVI CAVE 15 IV AND ITS CONTENTS (I. 96-98) xxvi 2 (II. 70), xxvi 9, 10 (II. 314)</p>

\* In vol. I. p. 82, line 12, for "bracket" read "bucket."

- PLATE  
XXVII  
ROCK-SURFACE WITH CUPS AND CAVES  
(I. 100-103)
- XXVIII  
CONTENTS OF CAVE 27 I (I. 110)  
1-3 (II. 370), 9 (II. 184), 20 (II. 449)
- XXIX  
1, 2. CONTENTS OF CAVE 27 I (*continued*)  
3-7. CONTENTS OF CAVE 30 III (I. 143)  
1 (II. 159)
- XXX  
DETAILS OF CAVE 28 II (I. 111-115)
- XXXI  
OBJECTS FROM CHAMBER (2),\* CAVE 28  
II (I. 120)  
1 (II. 260), 2 (I. 127), 3 (I. 129), 4-27  
(II. 314), 4-8 (I. 129), 11-14 (I. 126),  
13 (II. 450), 15 (I. 127), 16, 17 (I. 126),  
18 (I. 129), 19 (I. 119), 20, 23 (II. 260),  
24 (I. 127), 25 (I. 126, II. 450), 27 (I.  
120, 129), 30 (I. 129)
- XXXII  
POTTERY, ETC., FROM (2, 3, 4) \* CAVE 28  
II (I. 129, 130)  
1 (I. 120), 6 (I. 119, 124), 8-24 (I. 120)
- XXXIII  
POTTERY FROM THE CISTERN IN CHAMBER  
(2), CAVE 28 II (I. 120, 130)
- XXXIV  
IVORY, ETC., FROM CAVE 28 II (I. 122-  
125: *see also* II. 247, 248)  
13 (II. 243)
- XXXV  
SCARABS, ETC., FROM CAVE 28 II (I. 123,  
126-129, 141, II. 314)
- XXXVI  
POTTERY, ETC., FROM CAVE 28 II (I. 122-  
126, 129, 130)
- XXXVII-XLI  
POTTERY [FROM CAVE 28 II] (I. 122, 123,  
126, 130-135, II. 176)
- XLII  
ALABASTER [FROM CAVE 28 II] (I. 125, 135,  
II. 339)
- XLIII  
LATER OBJECTS [FROM CAVE 28 II] (I. 136)  
1 (I. 120), 3 (II. 198)
- XLIV  
1-6. CONTENTS OF CAVE 30 II (I. 143)  
7-10. CONTENTS OF CISTERN, S. END  
OF TRENCH 30 (I. 271)
- PLATE  
XLIV—*continued*.  
11-17. CONTENTS OF CISTERN IN CAVE  
14 I (185, 86)  
14, 15 (II. 329)
- XLV  
INTERIOR OF CAVE 30 IV SHEWING POSI-  
TIONS OF GRAFFITI (I. 145)
- XLVI, XLVII  
GRAFFITI IN CAVE 30 IV (I. 146-152)
- XLVIII  
GRAFFITI IN CAVE 30 IV (*continued*) AND  
PLAN OF THE CAVE  
OBJECTS FROM CAVES 6 I AND 7 II (I. 80)
- XLIX  
HOUSE PLANS (I. 169-173)  
7 (I. 175) 8, 9 (I. 201)
- L  
ROMAN BATH, YERDEH (I. 228-236)
- LI  
PLAN OF THE NORTH-EAST GATE (I. 240)
- LII  
THE WATER-PASSAGE (I. 256-264)
- LIII  
FRAGMENTS OF MOULDINGS [FOUND IN  
THE CENTRAL RESERVOIR] (I. 267)
- LIV  
RESERVOIR (I. 274)
- LV  
PHILISTINE TOMB DEPOSITS (I. 292)  
1, 2 (II. 339)
- LVI  
TOMB PLANS  
1 (I. 301), 2 (I. 304), 3-6 (I. 309), 7 (I.  
304), 8 (I. 309), 9-11 (I. 310), 12 (I.  
311), 13 (I. 312), 14 (I. 317), 15 (I. 320),  
16 (I. 321), 17 (I. 325), 18 (I. 353)
- LVII  
TOMB PLANS  
1 (I. 368), 2, (I. 380), 3 (I. 353), 4 (I.  
364), 5 (I. 365), 6 (I. 359), 7, 8 (I. 358),  
9 (I. 359), 10 (I. 344), 11 (I. 346), 12 (I.  
345), 13 (I. 343), 14 (I. 338), graffiti  
(I. 365)
- LVIII  
TOMB PLANS  
1 (I. 381), 2, 3 (I. 379), 4, 5 (I. 377), 6,  
7 (I. 376), 8 (I. 348), 9 (I. 381), 10, 11  
(I. 374), 12, 13 (I. 348), 14 (I. 347), 15  
(I. 366), 16 (I. 359, 361), 17 (I. 370)

\* Substitute these reference-figures for the letters in the plate-headings.

## PLATE

## LIX

## TOMB PLANS

1 (I. 384), 2 (I. 373), 3 (I. 370), 4 (I. 315, 316),  
5, 6 (I. 334), 7 (I. 372), 8 (I. 336), 9  
(I. 344, 345), 10 (I. 346), 11 (I. 387),  
12 (I. 311), 13 (I. 312), 14 (I. 340), 15  
(I. 350), 16 (I. 385)

## LX-LXIII

[DEPOSITS IN] TOMB No. 1 (I. 301, 302,  
II. 176)

lxiii 79, 80 (II. 314)

## LXIV-LXVIII

[DEPOSITS IN] TOMB No. 7 (I. 305-307,  
II. 156, 194)

lxvi 42 (II. 306) lxvii 1 (II. 156), 3 (II. 198)

## LXIX

TOMB No. 8 [PLAN AND DEPOSITS] (I. 307)  
14, 15 (II. 88)

## LXX, LXXI

TOMB No. 9 [PLAN AND DEPOSITS] (I.  
308, II. 156, 194)

## LXXII

TOMB DEPOSITS: 1-12, No. 18 (I. 310);  
13-20, No. 23 (I. 311); 21, 22, No.  
21 (I. 311); 23, No. 77 (I. 333)  
11 (II. 227), 18-20 (II. 240)

## LXXIII

[DEPOSITS IN] TOMB No. 28 (I. 312, II.  
211).

## LXXIV, LXXV

[DEPOSITS IN] TOMB No. 30 (I. 312-314,  
II. 194)

lxxiv 3 (II. 177), lxxv 15 (II. 351), 16  
(II. 347)

## LXXVI

TOMB No. 31 [PLAN AND DEPOSITS] (I.  
314, 315, II. 211)

## LXXVII

TOMBS No. 36, 228 (I. 316, 386)

## LXXVIII

TOMB DEPOSITS: 1-46, No. 40 (I. 317);  
47-49, No. 104 (I. 343); 50, 51 No.  
122 (I. 345) 14 (II. 298), 25 (II. 459),  
26 (II. 304), 38 (II. 87)

## LXXIX

TOMB DEPOSITS: 1-4, No. 44 (I. 319);  
5-27, No. 42 (I. 318, 319, II. 153);  
28-31, No. 46 (I. 319); 32-35, No. 53  
(I. 320); 36, No. 56 (I. 320); 37, 38,  
No. 125 a (I. 347); 39, 40, No. 182  
(I. 373)  
22 (II. 140, 24, 28 (II. 221), 30, 31, 37  
(II. 240)

## PLATE

## LXXX

[DEPOSITS IN] TOMB No. 56 (I. 320)

## LXXXI-LXXXIII

[DEPOSITS IN] TOMB No. 58 (I. 321-324,  
II. 194)

lxxxii 2 a (II. 180)

## LXXXIV, LXXXV

[DEPOSITS IN] TOMB No. 59 (I. 325-331)  
lxxxiv. 24 (II. 118)

## LXXXVI

[DEPOSITS IN] TOMBS No. 65-73 (I. 332)  
Ivory pin (II. 288)

## LXXXVII-LXXXIX

[DEPOSITS IN] TOMBS No. 84, 85 (I. 334,  
335, II. 211)

## XC, XCI

[DEPOSITS IN] TOMB No. 96 (I. 337, II.  
201, 211)

## XCII, XCIII

[DEPOSITS IN] TOMB No. 99 (I. 338, 339,  
II. 227)

xciii 11 (II. 454)

## XCIV

TOMB DEPOSITS: 1-14, No. 199 (*con-  
tinued*); 15-17, No. 89 (I. 335); 18-20,  
No. 82 (I. 334)  
6, 7 (II. 240)

## XCV-XCVII

[DEPOSITS IN] TOMB No. 103 (I. 340-342,  
II. 226)

xcvi 12 (II. 298)

## XCVIII

TOMB DEPOSITS: 1-15, No. 177 (I. 344);  
16-26, No. 124 (I. 346); 27-29, No.  
150 (I. 358)  
1-7 (II. 240)

## XCIX

TOMB DEPOSITS: 1-5, No. 118 (I. 345);  
6-12, No. 128 (I. 347); 13, No. 213  
(I. 381); 14, No. 158 (I. 365); 15,  
No. 169 (I. 369)  
1 (II. 269)

## C

TOMB DEPOSITS: 1, No. 123 (I. 345, 346);  
2-5, No. 131 (I. 349); 6-18, No. 64  
(I. 331, 332); (19-28, No. 56 (I. 321);  
29-31, No. 80 (I. 334)

## CI

[DEPOSITS IN] TOMB, No. 124 (I. 346)

## CI a

TOMB DEPOSITS: 1-12, No. 134 (I. 349);  
13-14 No. 206 (I. 380); 15, 16, No. 36  
(I. 316)

## PLATE

## CII

TOMB DEPOSITS: 1-6, No. 138 (I. 350);  
7-14, No. 139 (I. 352); 15, No. 7  
(I. 306); 16-28, No. 144 (I. 354)  
7-8 (II. 140)

## CIII

[DEPOSITS IN] TOMB No. 142 (I. 353,  
II. 211)  
5 (II. 166)

## CIV, CV

TOMB No. 147 [PLAN AND DEPOSITS] (I.  
355-358)  
civ 3 (II. 228)

## CVI

TOMB DEPOSITS: 1, 2, No. 152 (I. 358);  
3-6, No. 142, 143 (I. 354); 7, No. 66  
(I. 332); 8, No. 194 (I. 376)  
4 (II. 341)

## CVII

TOMB DEPOSITS: 1-19, No. 153 (I. 359);  
20, No. 227 (I. 386); 21-24, No. 242  
(I. 387 \* 388)  
23, 24 (II. 140)

## CVIII

TOMB No. 156 [PLAN AND DEPOSITS]  
(I. 361-364)  
7 (II. 140)

## CIX

TOMB DEPOSITS; 1-10, No. 157 (I. 364,  
365); 11-17, No. 218 (I. 383); 18-29,  
No. 76 (I. 333); 30, No. 148 (I. 358);  
31, No. 145 (I. 355); 32, No. 201 (I. 379)  
17, 19 (II. 140), 32 (II. 82)

## CX-CXII

TOMB No. 160 [PLAN AND DEPOSITS] (I.  
366, 367)  
cx 2, 3, 10 (II. 288), cxii 12 (455)

## CXIII

TOMB DEPOSITS: 1-9, No. 167 (I. 368,  
369); 10-20, No. 155 (I. 359-360);  
21-23, No. 158 (I. 365); 23 a, No. 128  
(I. 347); 24-27, No. 129 (I. 348)

## CXIV

[DEPOSITS IN] TOMB No. 176 (I. 370-372)

## CXV

TOMB No. 185 [PLAN AND DEPOSITS] (I.  
373, 374)  
1-4 (II. 88), 5 (II. 140), 12 (II. 9)

## CXVI

TOMB DEPOSITS: 1-3, No. 189 (I. 374,  
375); 4, No. 220 (I. 384); 5-8, No.

## PLATE

168 (I. 369); 9-13, No. 159 (I. 365,  
366); 14-19, No. 10 (I. 309); 20, 21,  
No. 33 (I. 316); 22, No. 154 (I. 359);  
23, No. 129 (I. 348)

## CXVII

[DEPOSITS IN TOMB] No. 193 (I. 375, 376)

## CXVIII

TOMB DEPOSITS: 1, No. 198 (I. 377);  
2, No. 205 (I. 379, 380); 3-18, No.  
196 (I. 376, 377); 19-22, No. 194 (I.  
376); 23-27, No. 219 (I. 383); 28, No.  
215 (I. 382)  
15, 16 (II. 228), 42 (II. 82)

## CXIX

TOMB DEPOSITS: 1-7, No. 201 (I. 378,  
379); 8-24, No. 199 (I. 377, 378);  
25, No. 200 (I. 378); 26-29, No. 208  
(I. 381)  
5, 6 (II. 240), 22 (II. 82), 25 (II. 240)

## CXX

TOMB DEPOSITS: 1, No. 226 (I. 386);  
2-15, No. 224 (I. 385); 16-19, No. 125  
(I. 346); 20-23, No. 223 (I. 384)  
16 (II. 140), 20 (II. 298), 21 (II. 82)

## CXXI, CXXII

TOMB No. 252 [PLAN AND DEPOSITS] (I.  
389-392)

## CXXIII

GLASS VASES [FROM TOMBS] (II. 240)  
1, 2 (I. 379), 3 (I. 380), 4 (I. 360), 5 (I. 359)  
6, 7 (I. 360)

## CXXIV-CXXVI

ANIMAL FIGURES (II. 1-22, 305)

cxxiv 1, 2, 3, 7, 8, 11, 17, 20, 23 (II. 2),  
19, 22, 25, 36, 37 (II. 3), 4, 9, 20, 28  
(II. 6), 29, 30, 31, 35 (II. 7), 6, 8 (II. 8),  
34 (II. 9), 18 (II. 15), 10, 16, 21 (II.  
16), 32 (II. 17), 15, (II. 18), 24 (II.  
19), 26, 27 (II. 20), 5, 12 13, 33, 38  
(II. 22)

cxxv. 9, 21 (II. 2), 4, 5, 6, 15, 16 (II. 3),  
20 (II. 4), 2, 14 (II. 6), 4, 8, 24 (II. 7),  
11, 17, 27 (II. 8), 18, 22 (II. 9), 19 (II.  
16), 3, 23 (II. 17), 12 (II. 18), 10, 13, 26  
(II. 19), 7, 25 (II. 22), 18 (II. 48)

cxxvi. 23 (II. 1), 17, 18, 22, 25, 26, (II. 2).  
4, 11, 14, 15, 16 (II. 3), 12, 24 (II. 6),  
5, 20 (II. 8), 9, 19 (II. 9), 8, 21 (II. 10),  
9 (II. 15), 1, 2, 3 (II. 16), 10 (II. 19),  
6, 13 (II. 22), 22 (II. 48, 159)

\* In vol. I. p. 387, line 6 from bottom, for "stoop" read "strap."

## PLATE

## CXXVII

THE CALENDAR TABLET (II. 24-28)

## CXXVIII

AGRICULTURAL IMPLEMENTS (II. 30-34)

9 (II. 124) .

## CXXIX

OLIVE-PRESSES (II. 48-67)

1, 2 (II. 49), 3 (II. 55), 4 (II. 53), 5 (II. 56), 6 (II. 59), 7, 8 (II. 57), 9 (II. 58, 226)

## CXXX

OLIVE-PRESSES OF NORMAL TYPE (II. 50)

## CXXXI

OLIVE-PRESS ARD AIN EL-BUTMEH f (II. 54)

## CXXXII

SPINDLEWHORLS AND BUTTONS (II. 70-73, 90-93)

4-9 (II. 71), 10-12, 14-20 (II. 72), 21, 22 (II. 73), 1, 37, 38, 53 (II. 90), 24-27, 29, 31-35, 40, 41, 43-49, 58 (II. 91), 2, 13, 23, 28, 30, 40-49, 51, 54, 60-63 (II. 92), 3, 17a, 36, 39, 42, 50, 52, 55, 56, 59 (II. 93)

## CXXXIII

BRONZE PINS AND NEEDLES (II. 78, 79) 82-90)

24, 26, 30, 48, 53 (II. 78), 31, 33-35, 37-40, 42, 49-52 (II. 79), 53 (II. 80), 1, 2, 4-9, 11, 15, 23 (II. 83), 3, 10, 12-14, 16-22, 25, 29, 54, 61, 63 (II. 84), 27, 28, 32, 36, 43, 56, 62, 67 (II. 85), 41 44-50, 53, 55, 57, 64, 65 (II. 86), 58-60, 66 (II. 87)

## CXXXIV

FIBULAE, ETC. (II. 79-82)

1-39, 42 (II. 80-82), 40 (II. 87), 41 (II. 97), 42 (II. 82, 100), 43 (II. 114)

## CXXXV

BRONZE ORNAMENTS, ETC.

1-12 (II. 115), 13-15 (II. 46), 16, 17 (II. 115), 19-22 (ornamental discs, top of a candelabra, and pin with two horizontal loops attached, from the Hellenistic stratum), 23 (II. 98), 23a (II. 101), 24 (II. 102), 25 (II. 47, 100), 26 (II. 100), 27-51 (II. 97-101)

## CXXXVI

SILVER AND GOLD

1 (II. 102), 2 (II. 450), 3 (II. 99), 4, 5 (II. 101), 6, 6a, 7 (II. 102), 8, 9 (II. 263), 10-16 (II. 261), 17 (II. 102, 261), 18 (II. 261), 19-22 (II. 260)

## PLATE

## CXXXVII

(a) HOARD OF BEADS, ETC. (II. 109-111),

(b) BEADS (II. 104-113)

## CXXXVIII, CXXXIX

FLINT IMPLEMENTS (II. 122-127: *see also* II. 244)

## CXL

POTTERY: COLOUR DECORATION (VARIOUS PERIODS)

1 (II. 135), 2 (II. 151), 3 (II. 188), 4 (II. 151), 5 (II. 173), 6 (II. 151), 7 (II. 173), 8 (II. 169, 173), 9 (II. 159), 10, 11 (II. 163, 173), 12-15 (II. 156, 173), 16 (II. 188), 17 (II. 191), 18 (II. 189, 191), 19 (II. 191), 20 (II. 189), 21 (II. 174, 180), 22 (II. 188, 191)

## CXLI-CL

FIRST SEMITIC POTTERY (II. 136-155)

cxli 5 (II. 139), 2, 8 (II. 140), 1, 3, 4, 6, 9-12 (II. 140), 1, 5, 7, 12 (II. 150), 5, 13 (II. 151)

cxlii 22 (II. 138), 1-5, 9, 11, 12 (II. 139), 14 (II. 140), 13, 17 (II. 141), 4, 21 (II. 143), 18 (II. 144), 20 (II. 147), 19 (II. 148), 15 (II. 149), 6, 9, 10, 16 (II. 160), 7, 8 (II. 162), 19 (II. 171)

cxliii 10, 16, 21 (II. 138), 11-13, 15, 19, 20 (II. 139), 14, 17, 18 (II. 140), 9 (II. 141), 1-8 (II. 142), 15 (II. 162)

cxliv 18 (II. 72), 5 (II. 138), 4 (II. 141), 12 (II. 142), 15 (II. 144), 14, 17 (II. 145), 2, 3, 6 (II. 146), 8 (II. 147), 7, 16 (II. 148), 9-11, 13 (II. 149)

cxlv 10 (II. 138), 14 (II. 139), 15, 16 (II. 140), 8, 9, 13, 17 (II. 141), 11 (II. 143), 12 (II. 146), 6, 17 (II. 150), 5 (II. 159), 1-4 (II. 161), 5 (II. 164), 18 (II. 166), 1, 2, 4 (II. 172), 3-5 (II. 173), 7 (II. 174)

cxlvi 8, 20 (II. 140), 4, 9, 11, 17 (II. 141), 13, 19 (II. 142), 6, 10 (II. 144), 16 (II. 145), 18 (II. 146), 5 (II. 147), 15 (II. 148), 14 (II. 150), 1-3 (II. 151), 21 (II. 152), 16a (II. 158), 7 (II. 161)

cxlvii 7, 18, 19 (II. 139), 3, 8, 10, 11, 25-27 (II. 140), 13, 20 (II. 141), 9, 12, 14, 22 (II. 142), 24 (II. 143), 4, 5 (II. 144), 1 (II. 145), 6 (II. 146) 21 (II. 147) 215 (II. 148), 16, 17, 23 (II. 150)

cxlviii 14 (II. 141), 3, 7, 10, 11, 23, 26, 28, 29 (II. 143), 2, 12, 13, 19, 27, (II. 144), 14 (II. 145), 8, 24 (II. 147), 5, 21, 22 (II. 148), 4, 8, 9, 15, 16, 25 (II. 149), 1, 6, 17, 18, 20 (II. 150)

cxlix 1, 4, 6 (II. 143), 3, 5, 13, 18-22, 25

## PLATE

- (II. 144), 4, 9 (II. 145), 8, 23, 26 (II. 147), 10 (II. 148), 11 (II. 149), 2, 7, 14, 15 (II. 150), 24 (II. 151), 12, 27 (II. 157), 16, 17 (II. 168)  
 cl. 12 (II. 143), 6, 8 (II. 144), 16, 18-20 (II. 148), 1-15, 17, 21 (II. 149), 13 (II. 150)

## CLI

AEGEAN POTSDHERDS (II. 155)

## CLII-CLVII

- SECOND SEMITIC POTTERY (II. 155-176)  
 clii 9 (II. 156), 1 (II. 159), 8, 17 (II. 161), 10 (II. 162), 21 (II. 163), 2, 5 (II. 165), 4, 3, 18 (II. 166), 6, 16, 20 (II. 167), 12 (II. 168), 8, 11, 14, 23, 24 (II. 170), 3, 7, 19, 22 (II. 171), 15 (II. 172), 3, 7 (II. 176)  
 cliii 10 (II. 156), 1-5 (II. 158), 6-10, 15, 18, 19 (II. 160), 7-10, 12-14, 17, 21 (II. 161), 11, 16, 20 (II. 162), 22 (II. 163), 24-26 (II. 164), 23 (II. 165), 28 (II. 167), 27 (II. 168), 20 (II. 171)  
 cliv 5, 29 (II. 160), 14, 16 (II. 161), 15, 22, 23 (II. 162), 8, 10, 12, 18-20 (II. 163), 1, 2, 4, 6, 7, 11, 17, 21, 24-26 (II. 164), 9, 13, 23, 28 (II. 166), 4 (II. 168), 27 (II. 171), 29 (II. 172), 3 (II. 175)  
 clv 3 (II. 163), 15, 21 (II. 165), 1, 5, 7, 11 (II. 167), 4, 14, 18 (II. 168), 2 (II. 169), 8, 10, 13-15, 19, 22, 23 (II. 170), 9, 16 (II. 171), 20 (II. 172), 6 (II. 175), 12, 17 (II. 176), 7 (II. 185)  
 clvi 1, 2, 10, 13, 16, 20 (II. 159), 3, 9, 11, 12, 15, 19 (II. 161), 4-6, 8, 14, 17, 18, 24 (II. 162), 25 (II. 163), 21 (II. 165), 1, 16, 22 (II. 167), 5, 7, 8, 11, 13, 24 (II. 168), 23 (II. 170), 3, 15 (II. 171), 26 (II. 172)  
 clvii 4 (II. 161), 1, 2, 3, 22 (II. 167), 18, 19, 21, 23, 25 (II. 170), 17, 20, 24 (II. 171), 20 (II. 172), 15 (II. 173), 7, 9 (II. 174), 1-3, 5, 6, 8, 10-14, 16 (II. 175)

## CLVIII-CLXVIII

- THIRD SEMITIC POTTERY (II. 176-194)  
 clviii 2 (II. 176), 3, 8 (II. 177), 15 (II. 178), 1, 7 (II. 180), 3, 11, 16 (II. 181), 9, 10, 12-14 (II. 182), 4, 10 (II. 183), 5 (II. 184), 6, 15 (II. 185), 1 (II. 187), 1, 3, 11, 15-17 (II. 188), 15 (II. 189)  
 clix 2-4 (II. 176), 9 (II. 183), 7, 8, 12 (II. 188), 18 (II. 187), 1, 7 (II. 189), 5, 8, 10, 14, 17 (II. 190), 15, 16 (II. 192), 6, 11 (II. 193), 6, 13, 16 (II. 194)

## PLATE

## CLVIII-CLXVIII—continued.

- clx 13 (II. 176), 1 (II. 178), 3, 11 (II. 187), 10 (II. 188), 2, 3, 14 (II. 189), 1, 5, 7, 9, 14 (II. 190), 1, 4, 6 (II. 192), 7, 8, 9, 12 (II. 194)  
 clxi 5, 8 (II. 177), 1, 2, 7 (II. 178), 3 (II. 179), 4, 6 (II. 180), 9, 10, 11, 13, 15 (II. 181), 14 (II. 183), 12 (II. 185), 1, 14 (II. 186), 16 (small saucer with painted decoration in black and red)  
 clxii 11, 13, 14 (II. 180), 2, 4, 7, 8, 12, 18, 19 (II. 181), 1, 3, 5, 15, 17, 20-22 (II. 182), 6, 9, 10 (II. 183), 16 (II. 185), 9 (II. 201)  
 clxiii 4 (II. 156), 4, 5, 9 (II. 178), 1-3 (II. 180), 4 (II. 187), 1, 3, 7 (II. 188), 2, 6, 7, 8 (II. 189), 137 (II. 192)  
 clxiv 2, 3, 6-8, 12, 13, 16, 17, 19, 21 (II. 177), 1, 4, 5, 9, 11, 14, 15 (II. 178), 18, 20 (II. 179), 10 (II. 180)  
 clxv 8 (II. 188), 3, 4 (II. 189), 2, 4, 10 (II. 190), 5 (II. 191), 1, 2, 9, 11 (II. 192), 1 (II. 193), 1, 2, 6 (II. 194)  
 clxvi 9 (II. 176), 3, 13 (II. 188), 2, 4, 7, 10 (II. 189), 4, 5, 7, 8, 11, 12, 14 (II. 190), 4, 10 (II. 191), 6 (II. 192), 1 (II. 194)  
 clxvii 3, 6, 9, 17 (II. 188), 17 (II. 189), 7, 10 (II. 190), 11, 16, 17 (II. 191), 8, 12, 15, 16 (II. 192), 13, 17 (II. 193), 1, 2, 4, 5 (II. 194)  
 clxviii 20 (II. 181), 2, 6, 12, 13, 15, 16, 17 (II. 185), 11, 14, 18, 19 (II. 186), 10 (II. 187), 7 (II. 192), 8, 9 (II. 193), 1, 3, 4, 5 (II. 194)

## CLXIX-CLXXXVI

- FOURTH SEMITIC POTTERY (II. 195-211)  
 clxix 16 (II. 158), 1, 22 (II. 195), 2-4, 8, 11, 13, 18, 19 (II. 196), 14, 19 (II. 197), 5, 15 (II. 198), 17, 20 (II. 199), 7, 9, 21 (II. 200), 6, 10, 12 (II. 201)  
 clxx 2, 7 (II. 196), 5, 6 (II. 198), 1 (II. 199), 3, 4, 9, 11-13, 16 (II. 200), 10, 14, 15, 17 (II. 201), 8 (II. 203), 5 (II. 207)  
 clxxi 7, 9 (II. 195), 2, 4, 12, 13 (II. 196), 3, 6, 11 (II. 197), 10 (II. 199), 14, 22 (II. 200), 15, 18 (II. 201), 16, 19 (II. 202), 20 (II. 203), 21 (II. 205), 1, 8 (II. 206), 5 (II. 207)  
 clxxii 19 (II. 166), 1, 2, 4-7, 20 (II. 195), 9, 21 (II. 196), 13, 17 (II. 197), 22 (II. 198), 12, 23 (II. 199), 15 (II. 201), 27 (II. 203), 8 (II. 204), 3 (II. 205), 10, 17 (II. 206), 14, 16, 18, 24-26 (II. 207), 11 (II. 208)



## PLATE

- CLXIX-CLXXVI—*continued*,  
 clxxiii 1 (II. 203), 2-17 (II. 208)  
 clxxiv 11 (II. 195), 15, 16 (II. 196), 2, 6,  
 7, 14, 19 (II. 200), 1, 3, 4, 5, 9, 10, 12,  
 13, 17 (II. 201), 8 (II. 203), 18 (II. 206)  
 clxxv 1 (II. 183), 10, 11 (II. 196), 7 (II.  
 198), 6 (II. 199), 9 (II. 201), 1 (II. 202),  
 2, 4, 5 (II. 203), 3, 8 (II. 206)  
 clxxvi 5 (II. 143), 10 (II. 196), 14 (II. 199),  
 6 (II. 200), 1-3, 11, 12 (II. 202), 4, 7,  
 18 (II. 204), 13 (II. 205), 8 (II. 206),  
 9, 16, 17 (II. 207), 15, 19 (II. 208)
- CLXXVII  
 GREEK POTSDHERDS (II. 212)
- CLXXVIII-CLXXXIV  
 HELLENISTIC POTTERY (II. 211-226)  
 clxxviii 7 (II. 212), 6 (II. 213), 1 (II. 215),  
 12 (II. 216), 11 (II. 218), 18 (II. 219),  
 3, 4, 9 (II. 220), 2, 5, 8, 15-17 (II. 221),  
 10, 13, 14 (II. 222)  
 clxxix 2-6 (II. 212), 12, 14 (II. 214), 15,  
 19, 21 (II. 215), 16, 18 (II. 216), 7-11,  
 13, 17, 22, 23, 25-27 (II. 217), 20, 30  
 (II. 220), 24, 28 (II. 221), 1, 29 (II. 222)  
 clxxx 1, 2 (II. 213), 3, 6, 8, 10, 11 (II.  
 214), 4, 5, 7, 14 (II. 215), 12 (II. 217),  
 9, 13 (II. 221)  
 clxxxi 1, 3, 6, 11, 14 (II. 214), 2, 4, 5,  
 6a, 8-10, 12, 13, 16 (II. 215), 7, 15  
 (II. 217)  
 clxxxii 2 (II. 213), 4 (II. 215), 3 (II. 216),  
 1, 15 (II. 217), 9, 10, 13 (II. 220), 5, 7,  
 (II. 221), 3, 6, 7, 11, 12 (II. 222), 8, 14  
 (II. 223)  
 clxxxiii (II. 218)  
 clxxxiv 11 (II. 216), 12 (II. 218), 13, 14  
 (II. 220), 1, 2, 4-8, 10 (II. 222), 3, 9,  
 10 (II. 223)
- CLXXXV-CLXXXVII  
 CONTENTS OF CISTERN IN IV 11 (II. 225)  
 clxxxv 4 (II. 166), 5 (II. 213), clxxxvi 1  
 (II. 207, 213, 221), 2 (II. 213), 3 (II. 217)  
 clxxxvii 13 (II. 217)
- CLXXXVIII  
 THE CANDLESTICK LAMP AND ITS VARI-  
 TIES (II. 227)
- CLXXXIX  
 ARAB POTTERY, ETC. (II. 229, 230)  
 34 (II. 244)
- CXC  
 POTTERS' MARKS  
 1-19a (II. 152), 20-41 (II. 176), 42-66  
 (II. 194), 67-88 (II. 209)

## PLATE

- CXCI  
 JAR-STOPPERS  
 1-5, 18 (II. 169), 6, 7, 8 (II. 186), 20 (II.  
 206), 9 (II. 209), 11, 14, 15 (II. 220),  
 12, 13, 16, 17, 19 (II. 221)
- CXCII  
 BRONZE AXE-HEADS (II. 241-243, 376)
- CXCIII  
 CARPENTERS' TOOLS (II. 244, 245)
- CXCIV  
 CARPENTERS' TOOLS (II. 245-247)
- CXCV  
 INLAYS (II. 248-250)
- CXCVI  
 STONE MISCELLANEA (II. 253-258)
- CXCVII  
 METAL MISCELLANEA, 1-27, BRONZE (II.  
 266-267), 26-41 IRON (II. 270, 271), 27  
 (II. 261)
- CXCVIII  
 KNIVES (BRONZE) (II. 268)
- CXCIX  
 KNIVES (IRON) (II. 271, 272)
- CC  
 SEALS (II. 294-298: *see also* 223)
- CCI  
 DRAUGHTBOARDS [AND DRAUGHTMEN] (I.  
 299-302)
- CCII-CCIX  
 SCARABS, ETC.  
*See lists of Seals* (II. 294, 330), Scarabs  
 (II. 314), Scarab-sealings (II. 329),  
 Cylinders (II. 344), and Amulets (II.  
 331), for descriptions of objects figured  
 on these plates.
- CCVb  
 PORCELAIN SAUCER (II. 338)
- CCX  
 EGYPTIAN AMULETS (II. 331-334)
- CCXI  
 EGYPTIAN FIGURES AND FAÏENCE  
 1-12 (II. 335), 13-28 (II. 337)
- CCXII  
 ALABASTER (II. 339-342)
- CCXIII  
 STONE SAUCERS (II. 273): ALABASTER  
 (*continued*)
- CCXIV  
 CYLINDERS, ETC. (II. 344-347)
- CCXV  
 ARROW- AND JAVELIN-HEADS (II. 371-374)

## PLATE

- CCXVI  
BRONZE SPEAR-HEADS (II. 374-375)
- CCXVII  
SPEAR-HEADS (II. 375)
- CCXVIII  
SWORDS, ETC. (II. 375, 376)
- CCXIX  
SHAKÎF EZ-ZUTT (II. 411)
- CCXX, CCXXI  
HATHOR-ASHTORETH PLAQUES (II. 411-416)

## PLATE

- CCXXII, CCXXIII  
LIMESTONE FIGURES (II. 421-423)  
Standing Stones in **V 29** (II. 406)
- CCXXIV  
TABLES OF OFFERINGS (II. 425-447)
- CCXXV  
*Ex Voto* OFFERINGS (II. 437-446)  
13 (II. 21, 446)
- CCXXVI  
Amulets (II. 450-453)

A TABLE OF REFERENCE-LETTERS ON THE PLANS,  
PLATES I-VII \*

a, Cup-mark	j, Jar-burial	r, Reservoir
b, Pillar-base	k, Brick	s, Stone doorpost
c, Cistern	l, Lamp-and-bowl deposit	t, Baking oven
d, Drain or watercourse	m, Olive-press	v, Vat
i, Interment	p, Pavement	x, y, z, <i>See</i> I. 162

- I 2 A, Hollow in rock, I. 153.  
 I 2 B, Olive-press in rock, II. 49 (where *for* "I 1 C" *read* "I 2 B").  
 I 4 A, Rock-cuttings associated with Cave 4 I, I. 78.  
 I 4 (S end), Group of cup-marks, etc., I. 154 (where *for* "I 5 A B" *read* "I 4 S. end").  
 I 5 A, Cup-marks united by a channel, I. 154 (where *for* "I 6 N. end" *read* "I 5 A").  
 I 8 A, Step against a house-wall, I. 186.  
 I 10 A, Natural hollow with vats, I. 154.  
 I 12 A, Cup-marks united by a channel, I. 154.  
 I 15 A, Cup-hollow in rock, 3' 6" across, 4' deep, found full of barley.  
 I 19 A, Natural hollow artificially rounded, I. 154, II. 387.  
 I 21 A, Circular pit in rock, 6' 6" across, 1' 6" deep (probably an olive-press).  
 I 29 A, Rock-cut vat, I. 155, 156.  
 I 30 A, Masonry surrounding rock-cutting, I. 154.  
 II 1 (middle), Hearth, I. 198 (where *for* "D east of trench I" *read* "in middle of trench I").  
 II 2 A, Standing stone, I. 237, II. 377, 378.  
 II 3 A, Foundation deposit, II. 427.  
 II 4 A, Domestic altar, II. 425.  
 II 4 B, Heap of stones, I. 191 (where *for* "II 3 B" *read* "II 4 B").  
 II 4 C, Pit in rock I. 153 (where make a similar correction).  
 II 5 A, A circular vat about 7' in depth, built of stone, plastered inside.  
 II 13 A, Room of a house destroyed by fire, containing a large number of weavers' weights and burnt corn.  
 II 17 bb Well-rounded pillar-bases, I. 192 (where *for* "II 17 cc" *read* "II 17 bb").  
 II 18 A, Rock dwelling adapted as a cistern, I. 269.  
 II 20 A, Hearth of four stones on end, I. 195.  
 II 20 B, Brick walls in the High Place Area, II. 399.  
 II 20 C, Circular structure full of burnt corn.  
 II 20 D, Hearth, I. 195.

\* After the early sheets of vol. I had been printed off it was decided that to print the lettering on these maps in blue would be unnecessary. The footnote on p. ix must therefore be revised.

- II 20 E, Masonry with vertical shaft, I. 201 *note*.  
 II 21 A, Shaft in city wall, I. 203.  
 II 21 B, Jar-burial with pottery, II. 432.  
 II 21 C, Flat stone, 2' 4" across.  
 II 26 A, Cemented pool, I. 276, 277.  
 II 28 A, Circular structure of massive masonry about 6' diameter.  
 III 2 B, Cistern containing skeletons, II. 429.  
 III 13 A, Inverted perforated jar (? beehive), II. 67, 68.  
 III 13 B, Door-socket shewn in I. 184, fig. 71.  
 III 13 C, Position of hoard of beads described II. 109 *et seq.*  
 III 18 A, Pillar-base, I. 192.  
 III 20 A, Pile of skulls, II. 367.  
 III 21 A, Shaft in city wall, I. 203.  
 III 27 A, Large pile of flint chips.  
 III 30 A, Two slabs on edge at right angles, with a pile of pottery vessels leaning against them. (In I. 192 *for* "III 30 A" *read* "at N. end of III 29.")  
 IV 2 B, Cistern containing skeletons, II. 429.  
 IV 4 A-D, Details in house, described, I. 196.  
 IV 8 A, Deep grain-pit, I. 201.  
 IV 8 B, Chamber with large stones in the foundation of its walls, I. 176.  
 IV 18 A, Square building associated with cup-mark, I. 154.  
 IV 19 A (north), Four jars standing on end.  
 IV 19 A (south),  $\phi$ -shaped chamber, I. 203, 204 (*where for* "at the S. end of V 19" *read* "at IV 19 A").  
 IV 21 A, Row of stones in floor of house, I. 191, fig. 79.  
 IV 26 A, Wall 2' thick resembling the wall *aa* described in II. 406, built of long stones : one of them 4' in length.  
 IV 29 C, Set of steps, I. 194.  
 IV 30 A, Large olive-press, described, II. 66-67.  
 IV 30 B, Tapering slab standing on end, 2' 5" high, 1' thick, 1' 10" broad at bottom, 1' 4" at top, with a round hole 9" in diameter pierced through 3½" below the top. (In I. 192, line 26, insert "south of" before "IV 30 B.")  
 V 2 B, Cistern containing skeletons, II. 429.  
 V 3 A, Hearth, I. 199.  
 V 4 A B, Long wall descending to rock, I. 166.  
 V 5 B (in the chamber S. of the thick wall), Drain of jars, I. 278.  
 V 9 A, Stones on edge, probably a hearth, I. 195.  
 V 13 A (the round structure), Granary, I. 196.  
 V 20 A, The chamber which contained the Ashtoreth Karnaim, II. 419.  
 V 20 B, Collection of stone weights of an olive-press.  
 V 20 C, D, Stone columns, I. 192.  
 V 21 A, Circular wall plastered inside.  
 V 21 B, Long flat stone slab, II. 65.  
 V 21 C, Small vat full of black ashes, II. 65.  
 V 28 A, Columns of a verandah, I. 191.  
 V 29 A, Circular vat 3' 6" deep, built up of stones lined with cement.  
 V 30 A, (the wall running east and west at the extreme top of the trench), Wall described, I. 177 (*where for* "V 29 A" *read* "V 30 A").

- V 30 A (south), Standing stone 4' 5" high  $\times$  2'  $\times$  1' 4" tapering to top.
- V 30 B, Stone with hieroglyphic letter, II. 307. (In I. 272 insert the words "a pit north-west of" before "V 30 B.")
- V 30 C, Drum of a column lying on the wall, 1' 7" in diameter, 1' high.
- VI 2 A, The Maccabean wall, I. 280-282.
- VI 2 B, The cistern containing skeletons, II. 429.
- VI 3 A, Water channel, I. 277, 278.
- VI 4 A, Pillar-base, I. 192.
- VI 14 A (the block at the middle of the upper long wall, east of the reservoir), Step, I. 195.
- VI 18 A, Peculiar cistern, I. 270.
- VI 21 A, Midden-heap, II. 21.
- VI 27 A, Long stone running through wall, I. 179.
- VI 27 B, Flight of steps, I. 195.
- VI 28 A (north), Fragment of pavement, I. 184.
- VI 28 A (south), Stone door-post with hole drilled for bolt.
- VI 29 A, (north) Water drain, I. 278.
- VI 29 A (south), Wall shewn, I. 178, fig. 65).
- VI 29 B (on the course of the wall running eastward from D in trench 30, and immediately south of the broken angle above it), Opening spanned by lintel, I. 187 (where read "VI 29 B" for "VI 17 B.")
- VI 29 B (south), Vat in pavement, I. 184.
- VI 29 C, Colonnade, I. 193.
- VI 29 D, Hearth, I. 195.
- VI 30 A, B, Circular structures, I. 201.
- VI 30 C, Two stones described and illustrated, I. 186.
- VI 30 D, Reconstructed building, I. 175.
- VI 30 E, Block of stone, 1' 6"  $\times$  1' 7"  $\times$  1' 8", I. 192 (where for "VI 18 E" read "VI 30 E.")
- II a 29 A, Vat in plastered pavement, I. 183.
- II a 29 B, Brick step, I. 194.
- III a 30 A, Circular pits in pavement (so lettered), I. 184: beside them a wall referred to in I. 176.
- III a 30 B, Pavement of four large flat stones (so lettered), I. 183.
- V a 27 A, Fragment of pavement sloping upwards at an angle of about 30°.
- V a 29 A, Row of three stones end to end, I. 178.
- V a 30 A, Pillars with square drums, I. 192.



# INTERMEDIATE STRATA ON WESTERN HILL

IIa  
(between II and III - circa B.C. 2000)

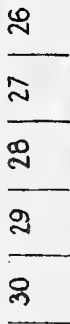

IIIa  
(between III and IV - circa B.C. 1500)

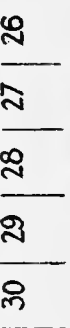

Va  
(between V and VI - circa B.C. 700)

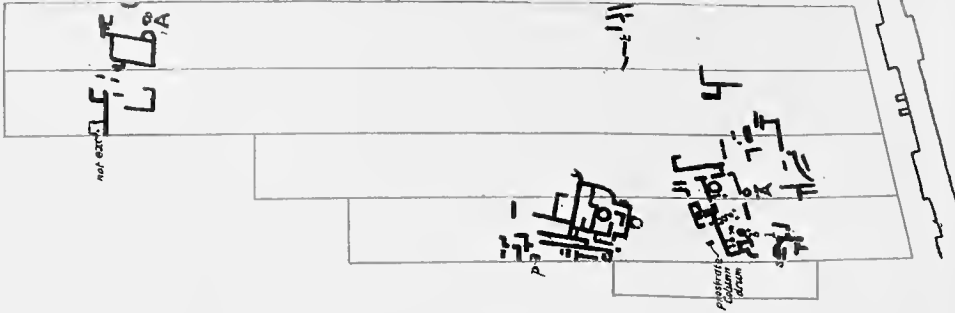
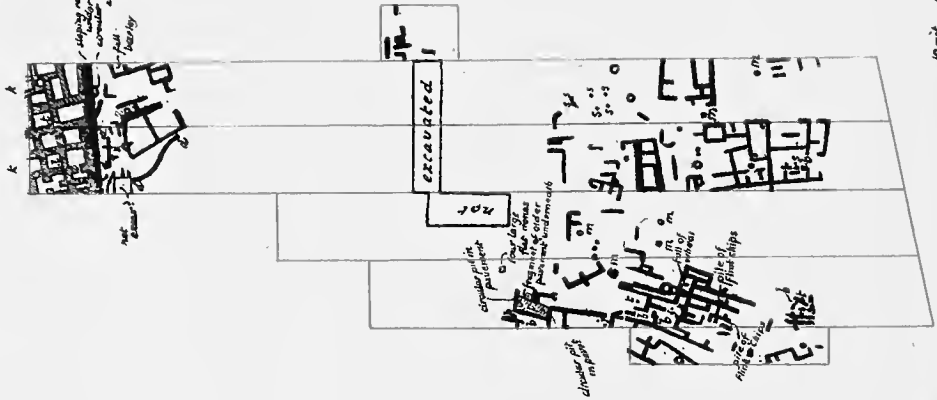





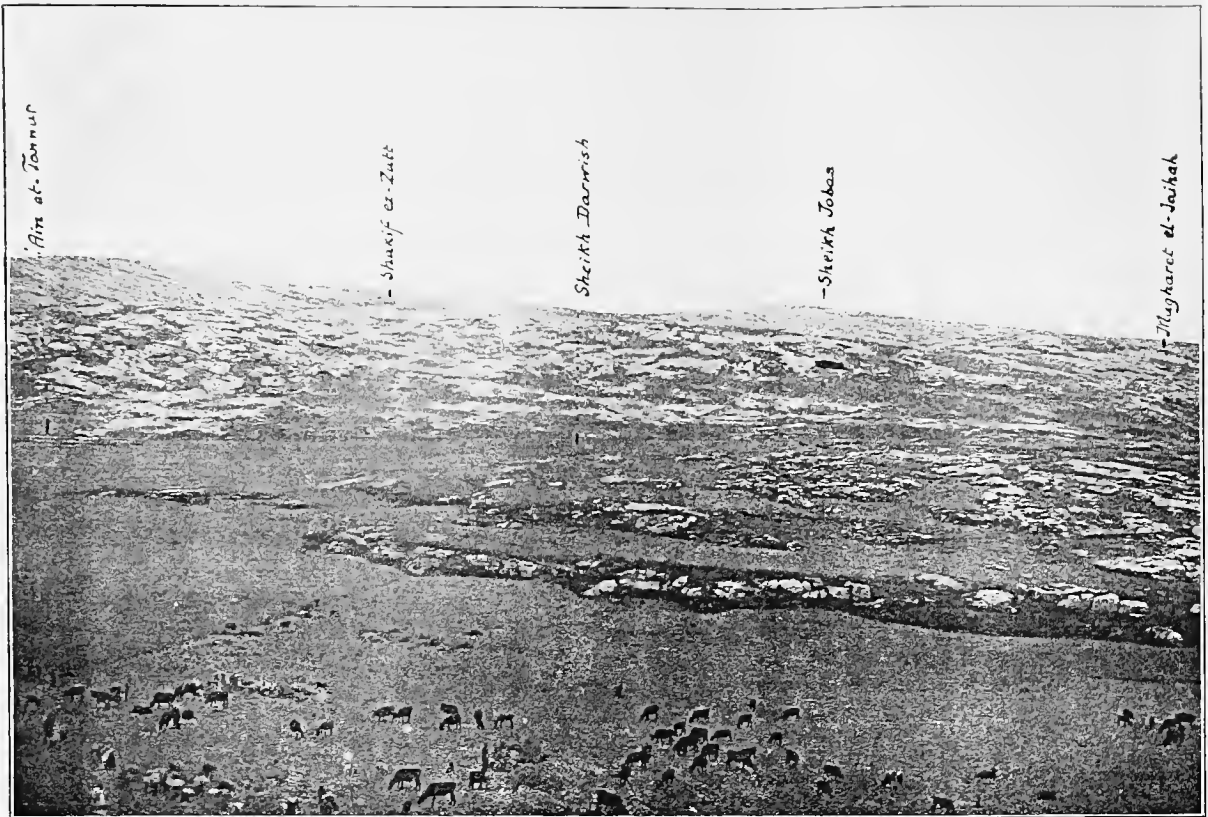

FIG. 1: HILLS SOUTH OF GEZER



FIG. 2: THE "ḤAJAR IBRAHĪM"



FIG. 1



FIG. 2



FIG. 3







Fig. 3

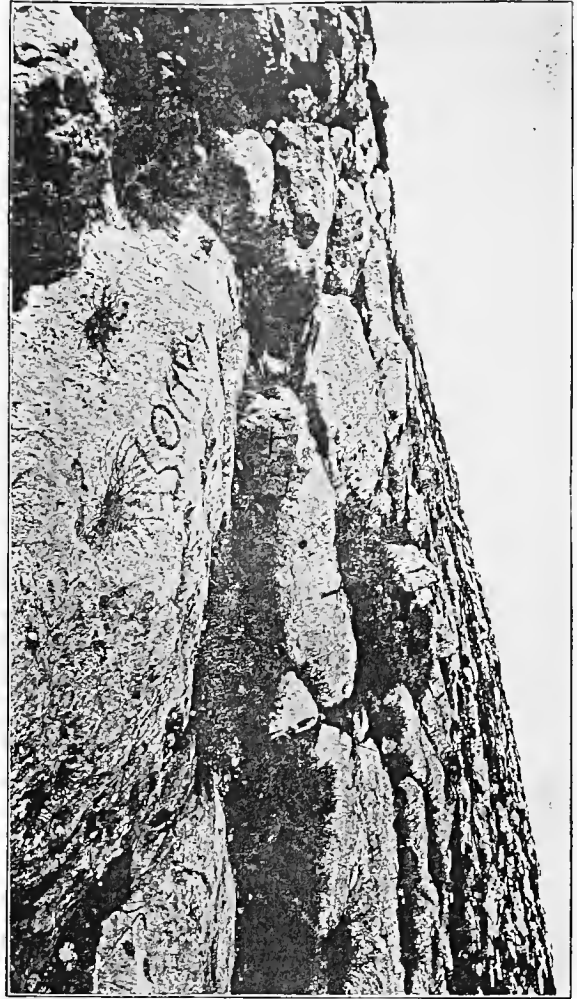

Fig. 1



Fig. 4



Fig. 2









CAVE PLANS

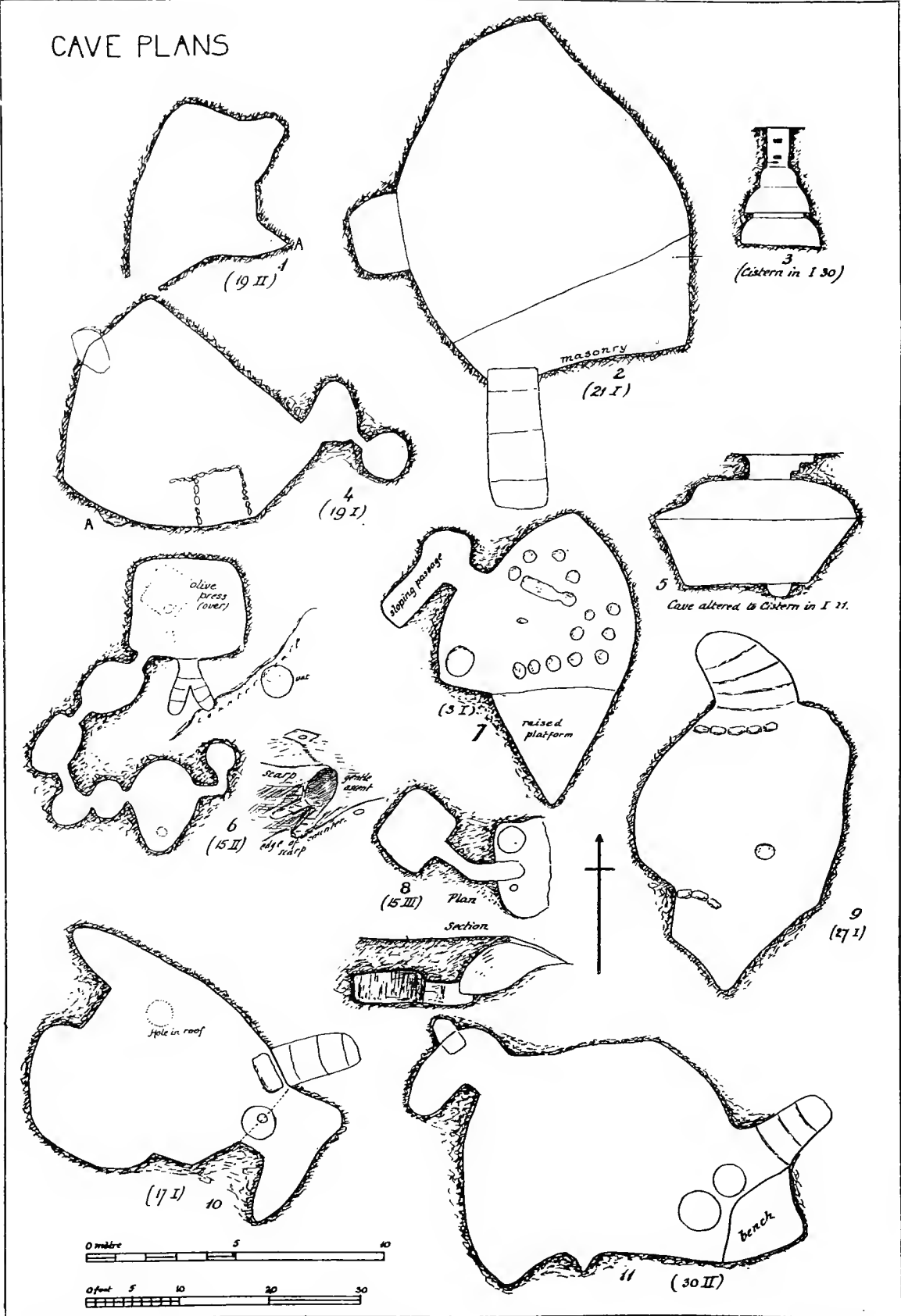

CAVE PLANS

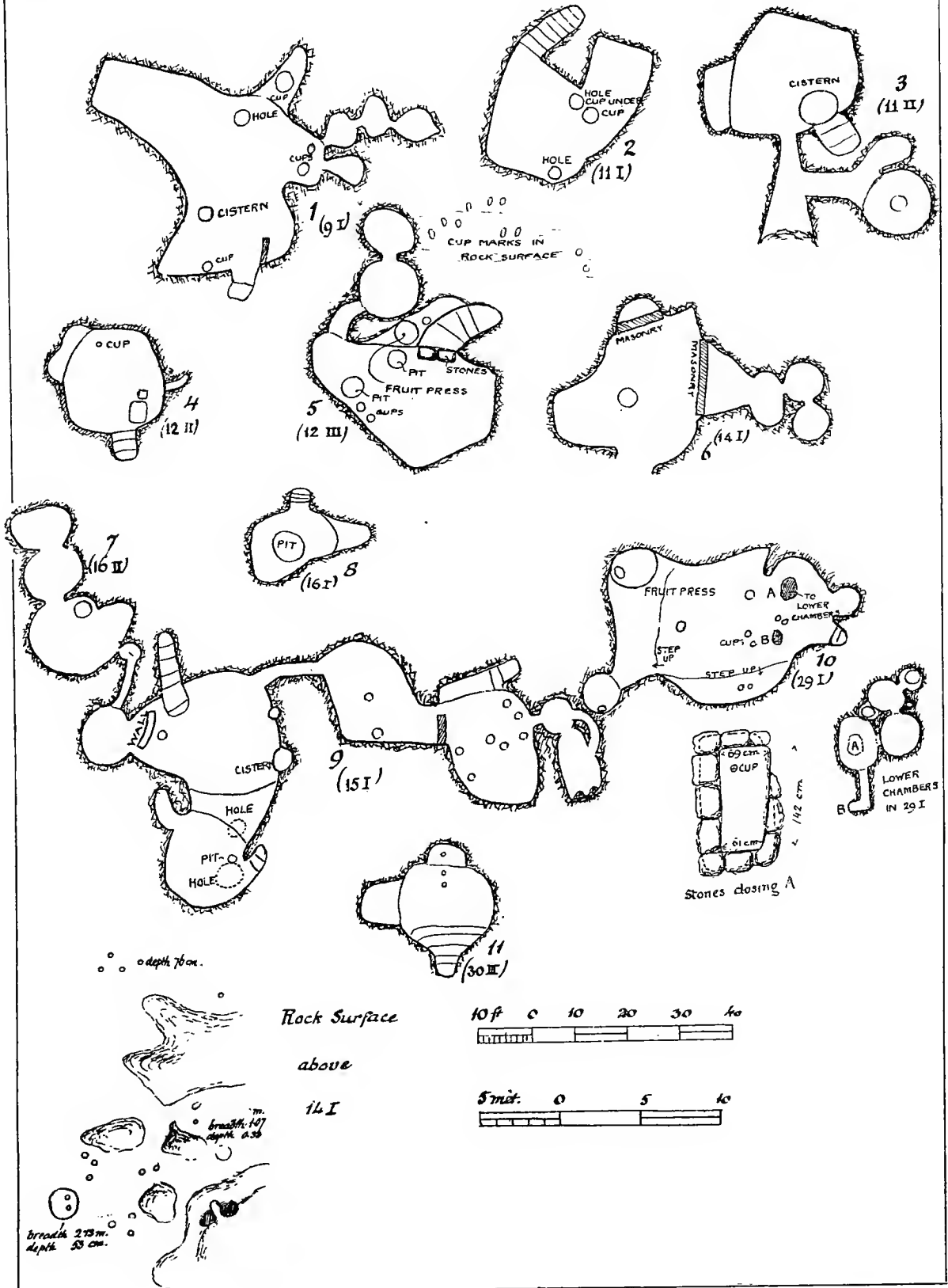



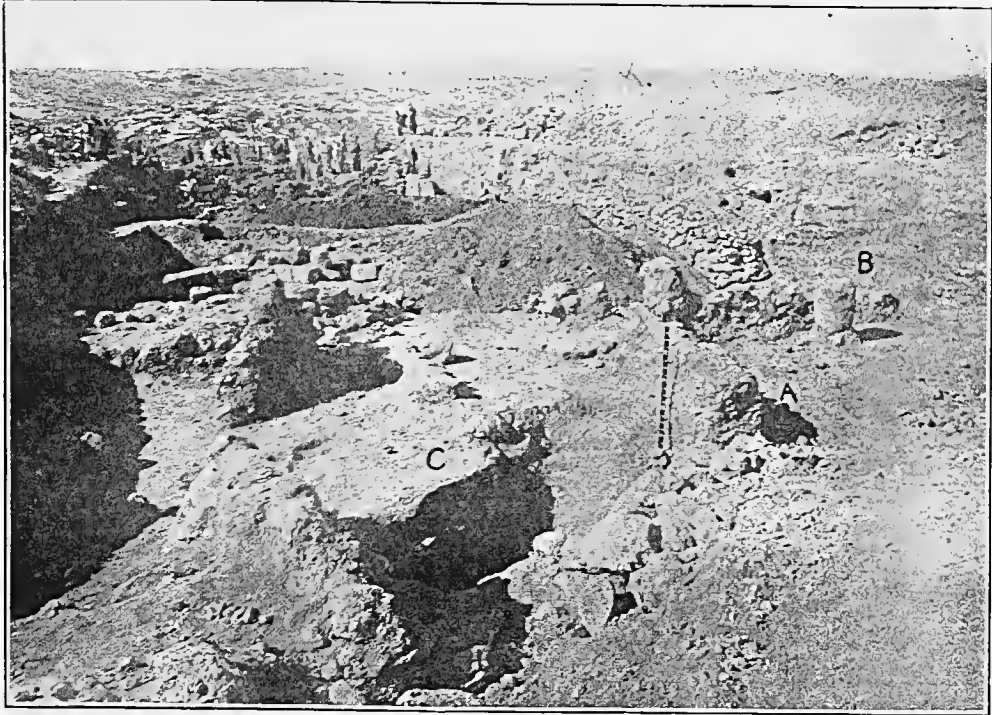

FIG. 1

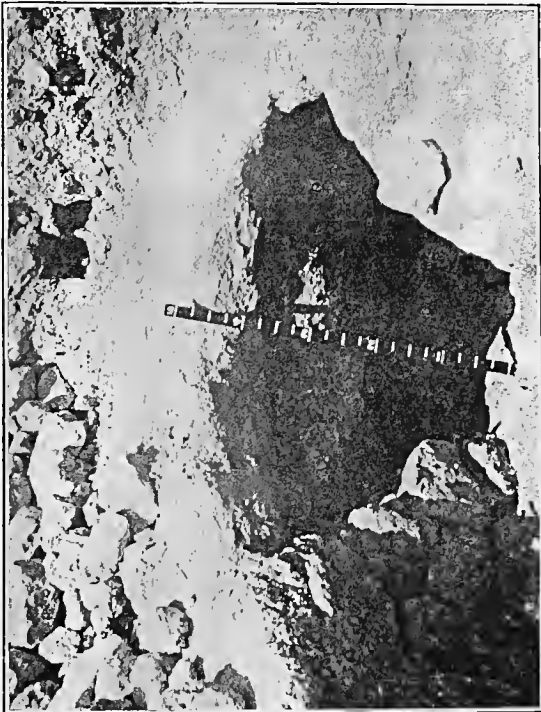

FIG. 2







# CAVE 3 III AND ITS CONTENTS

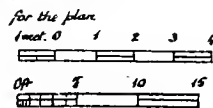
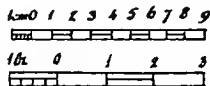
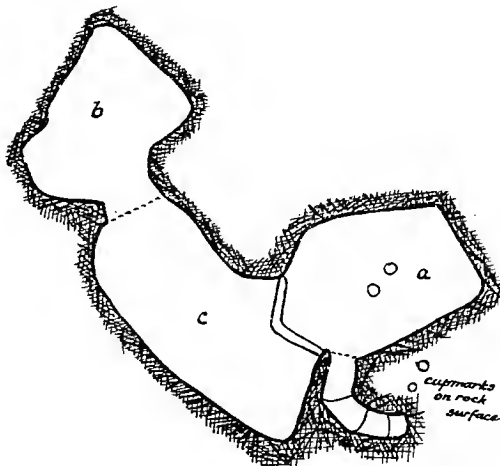
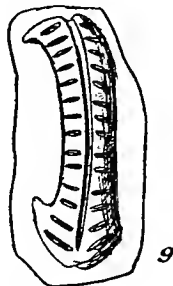
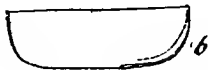
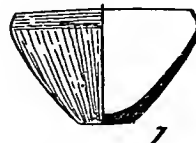
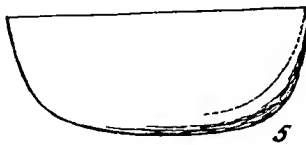
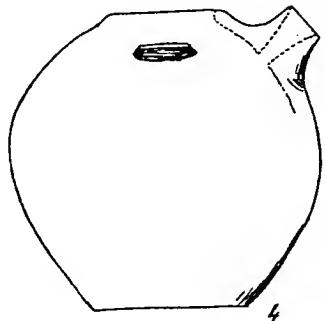
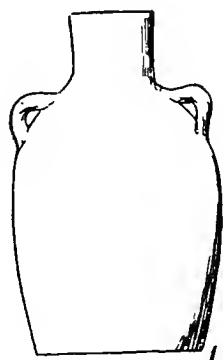

# ROCK SCARP WITH CUP MARKS

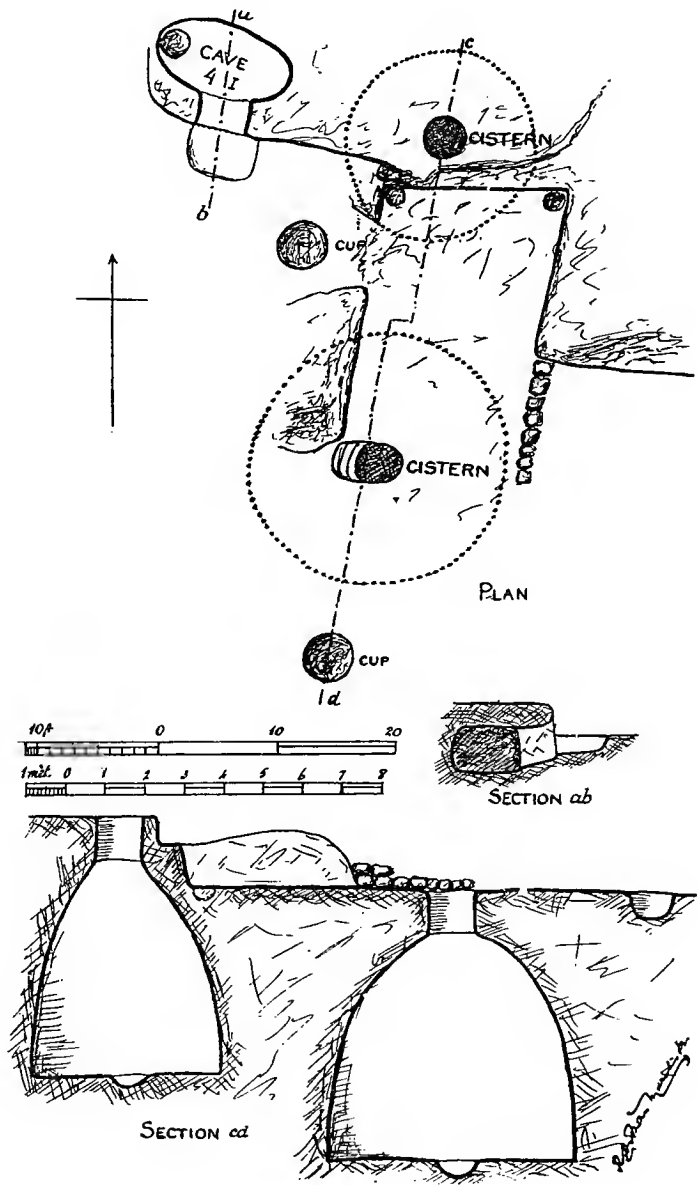







CONTENTS OF CAVE 81

0cm 1 2 3 4 5 0in 1 2 3  
fig. 25 to 1/4 scale, 28 to 1/2 scale



### CONTENTS OF CAVE 11 II

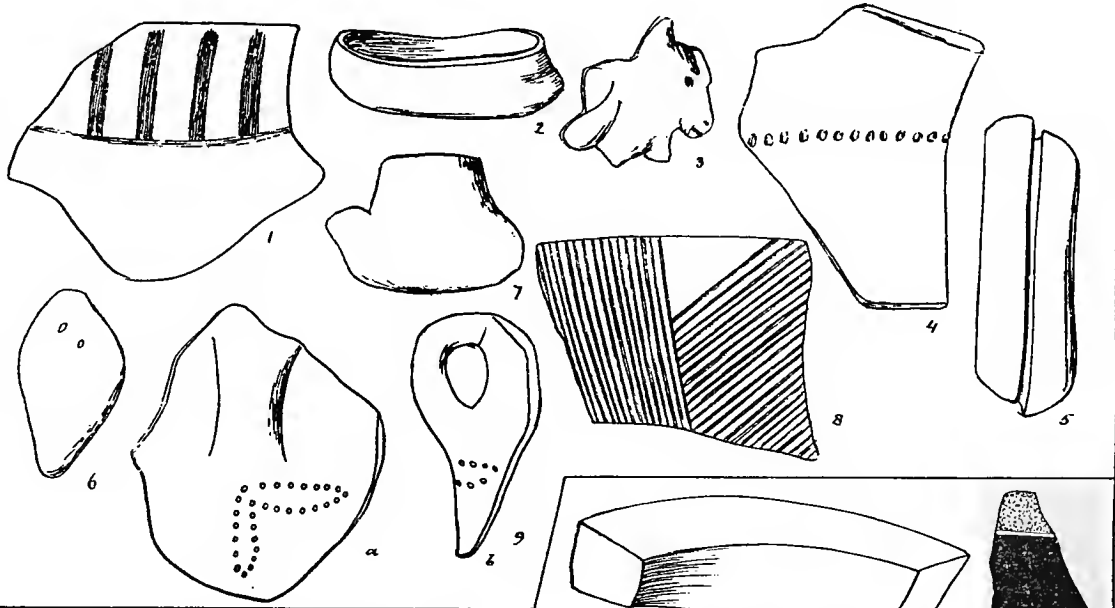

### CONTENTS OF WATER-PASSAGE



### CONTENTS OF CISTERN

### EAST OF TOMB No. 11

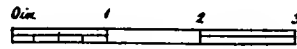
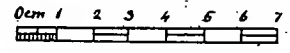
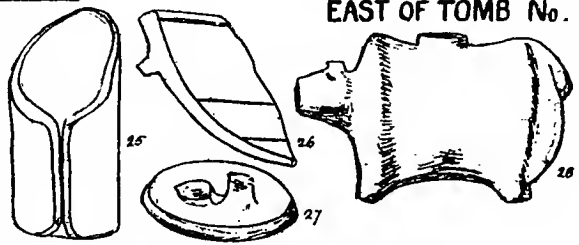

figs 25, 26, 28 to half scale.





# CONTENTS OF CAVE 15 I

0 in 1 2 3 0 cm 2 4 6

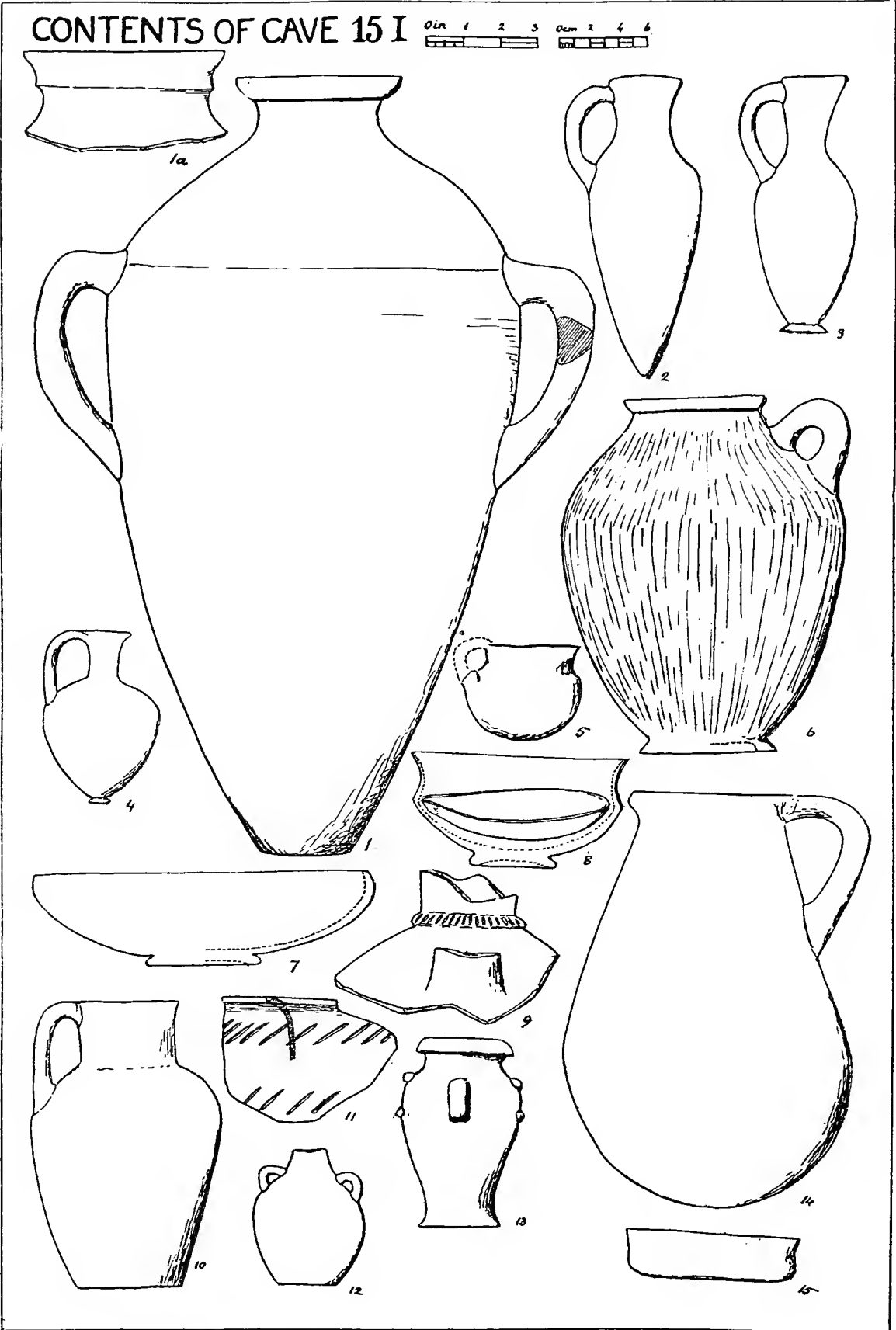

CONTENTS OF CAVE 151

0 cm 1 2 3 4  
1 cm 1 2 3 4  
figs 1-3, 17, 24, 27 half scale; fig 26 quarter scale

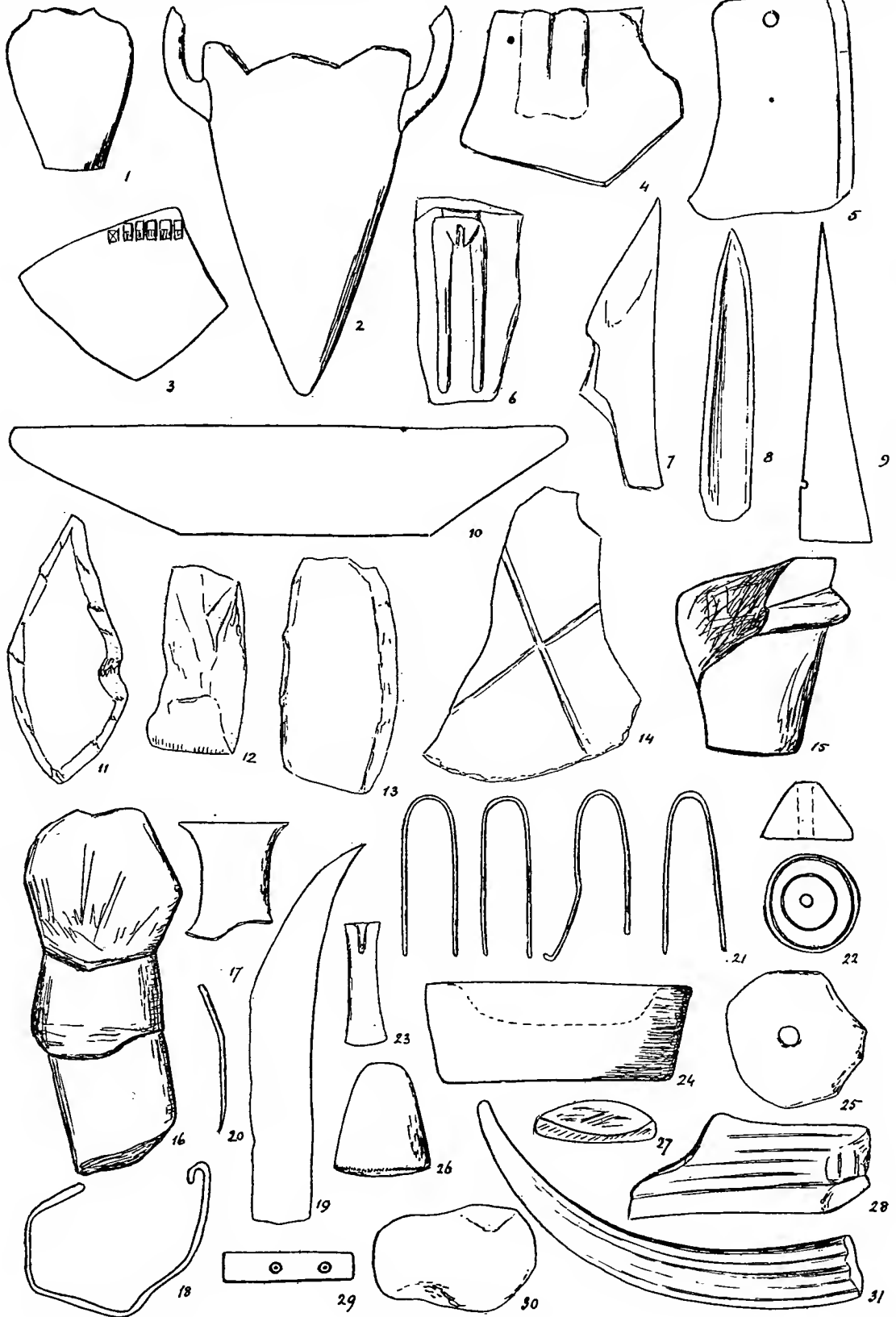







CONTENTS OF CAVE 15 I

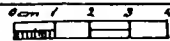
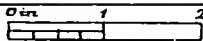

*figs 2, 3, 5 to half scale*



### CONTENTS OF CAVE 15 I

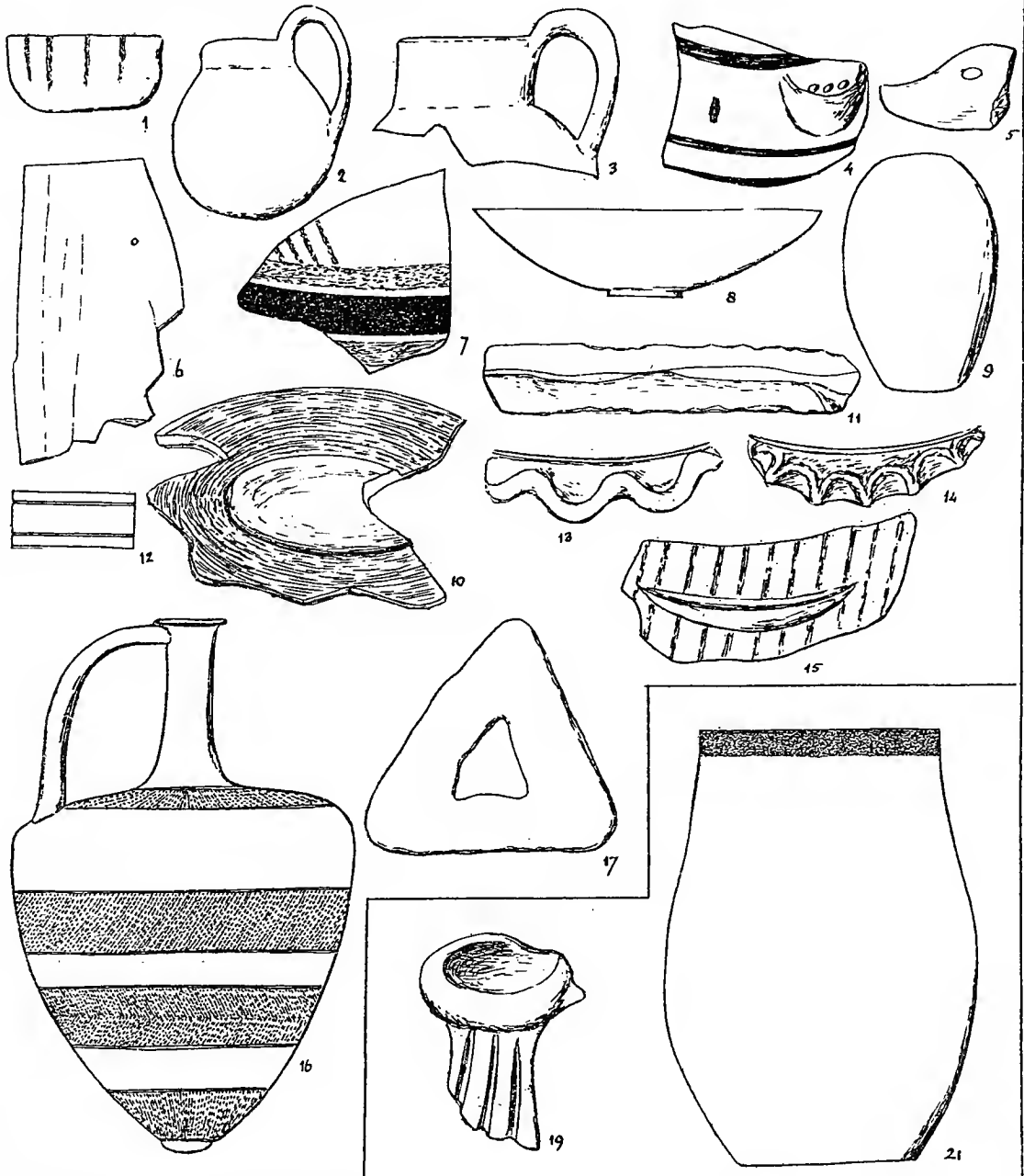

### CONTENTS OF CAVE 30 IIa

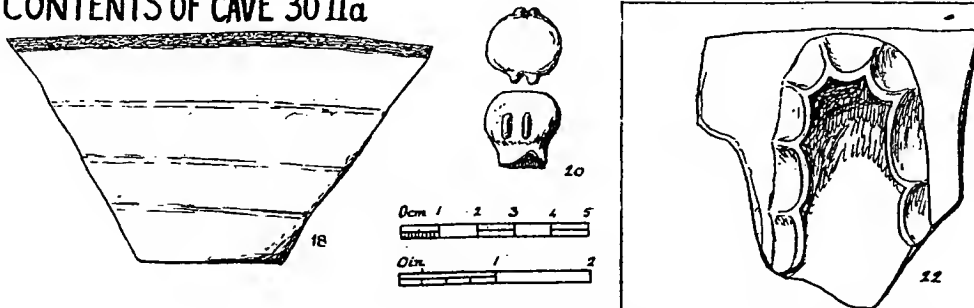





CONTENTS OF CISTERN IN CAVE 15,II

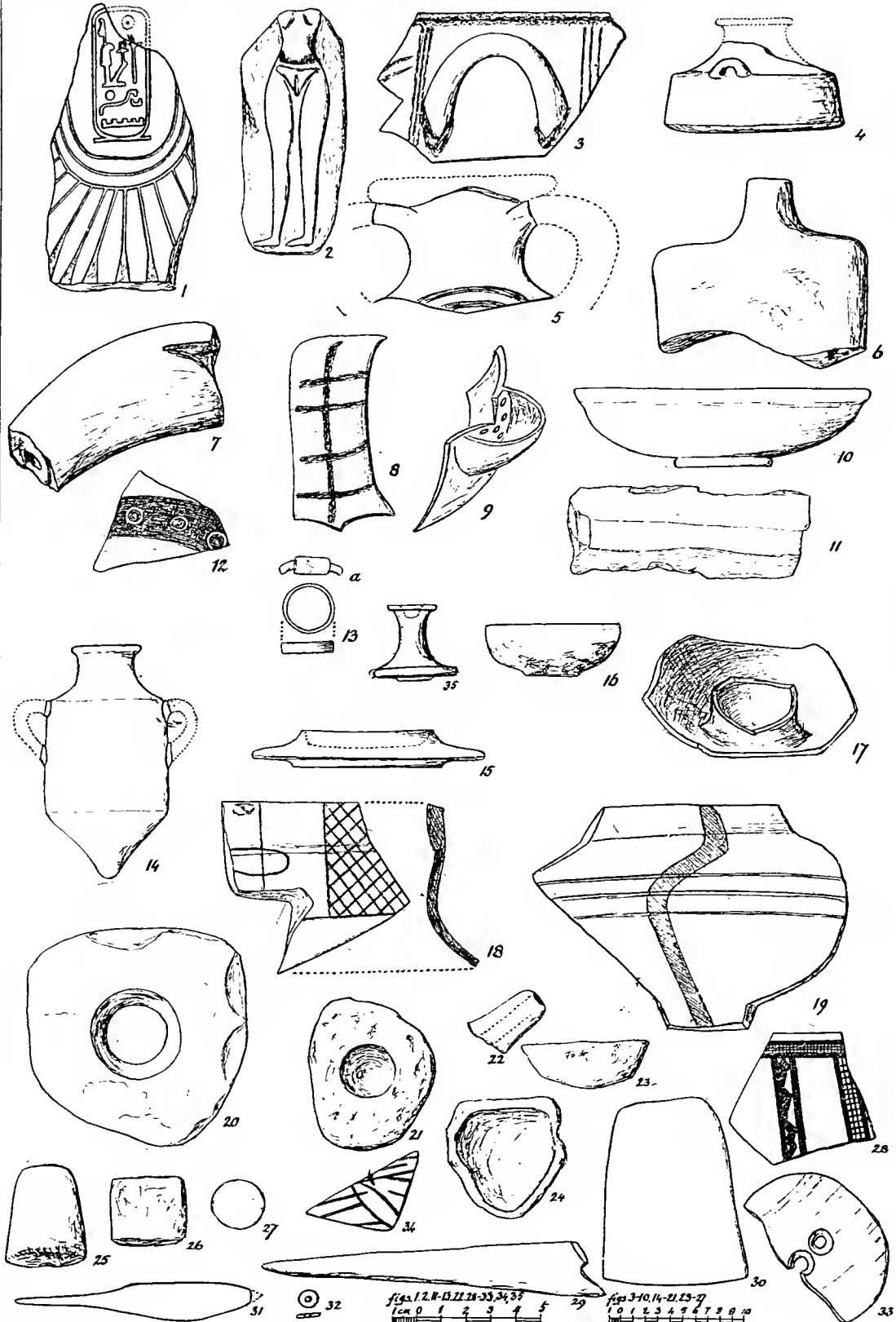

# CAVE 15 IV AND ITS CONTENTS

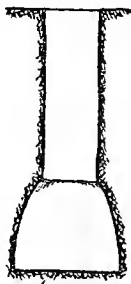
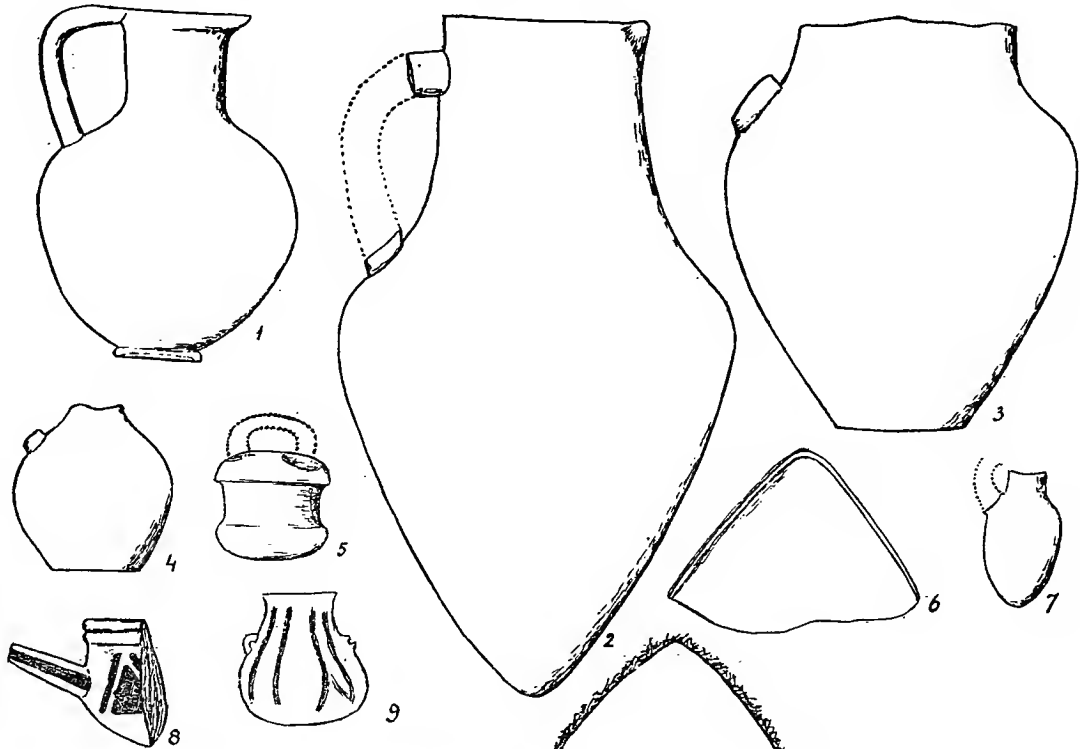

Section of D

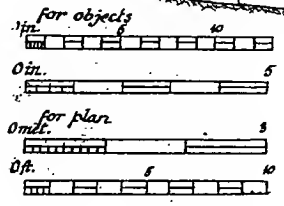
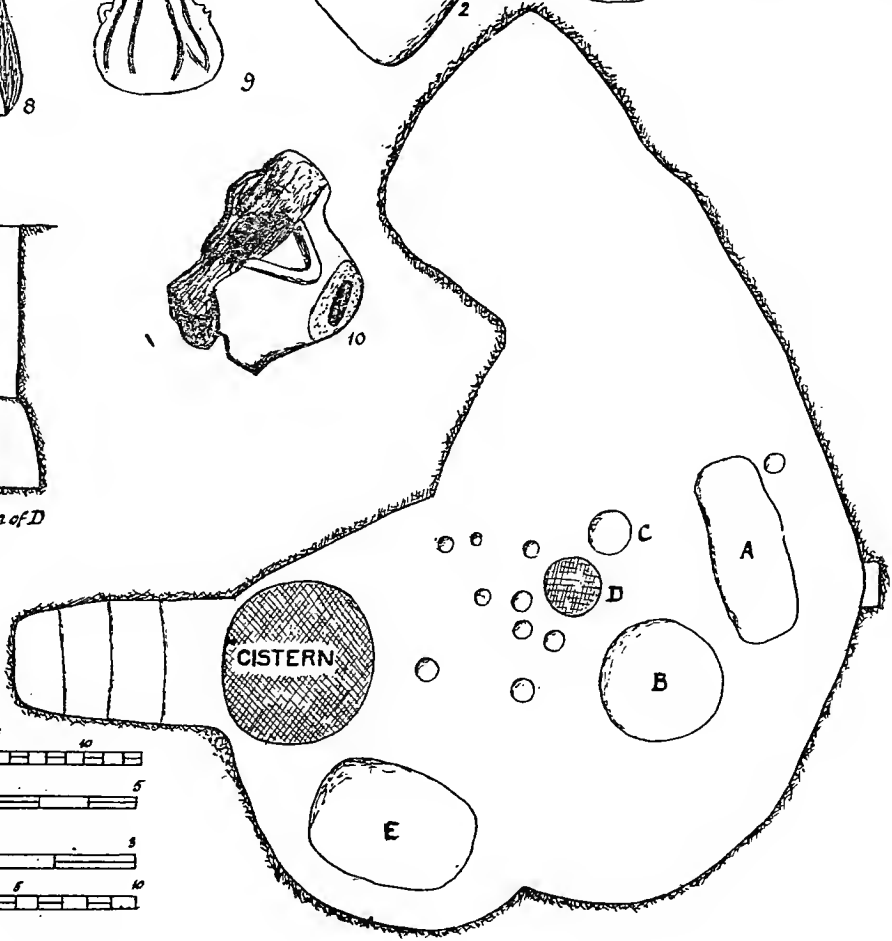







CONTENTS OF CAVE 15 IV

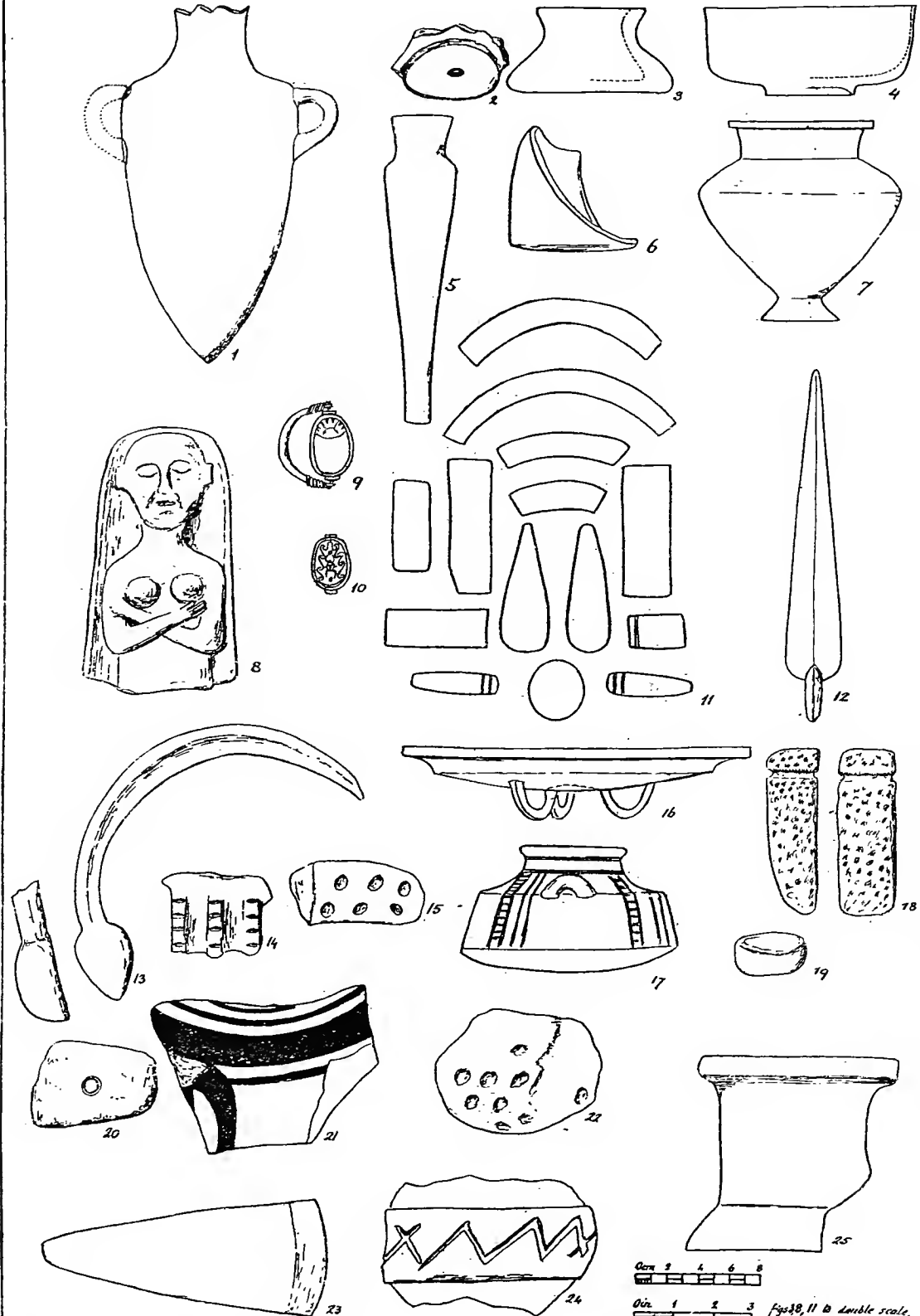

0cm 2 4 6 8  
0in 1 2 3  
Figs 8, 11 to double scale,  
also fig. 21.

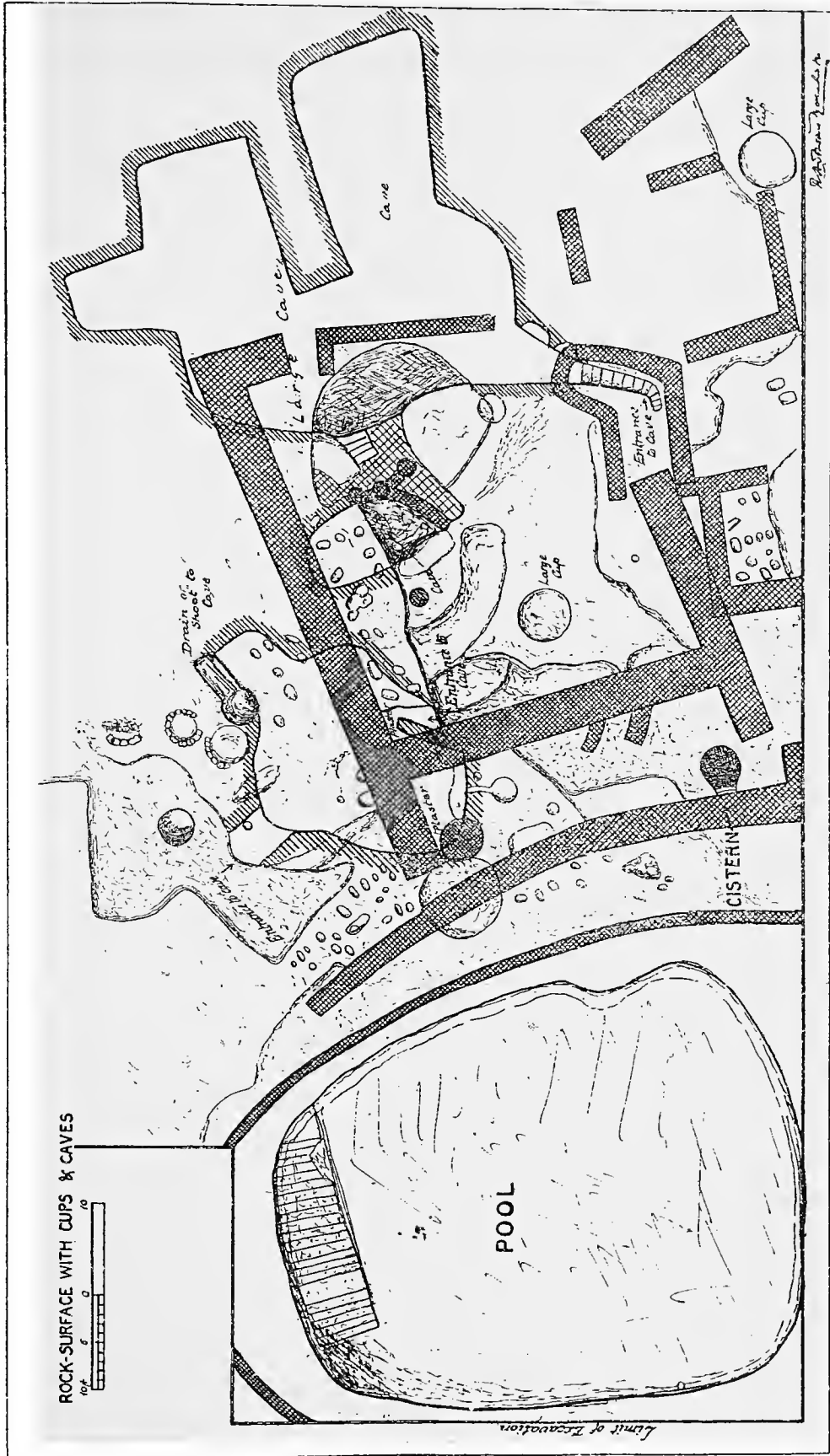





CONTENTS OF CAVE 271

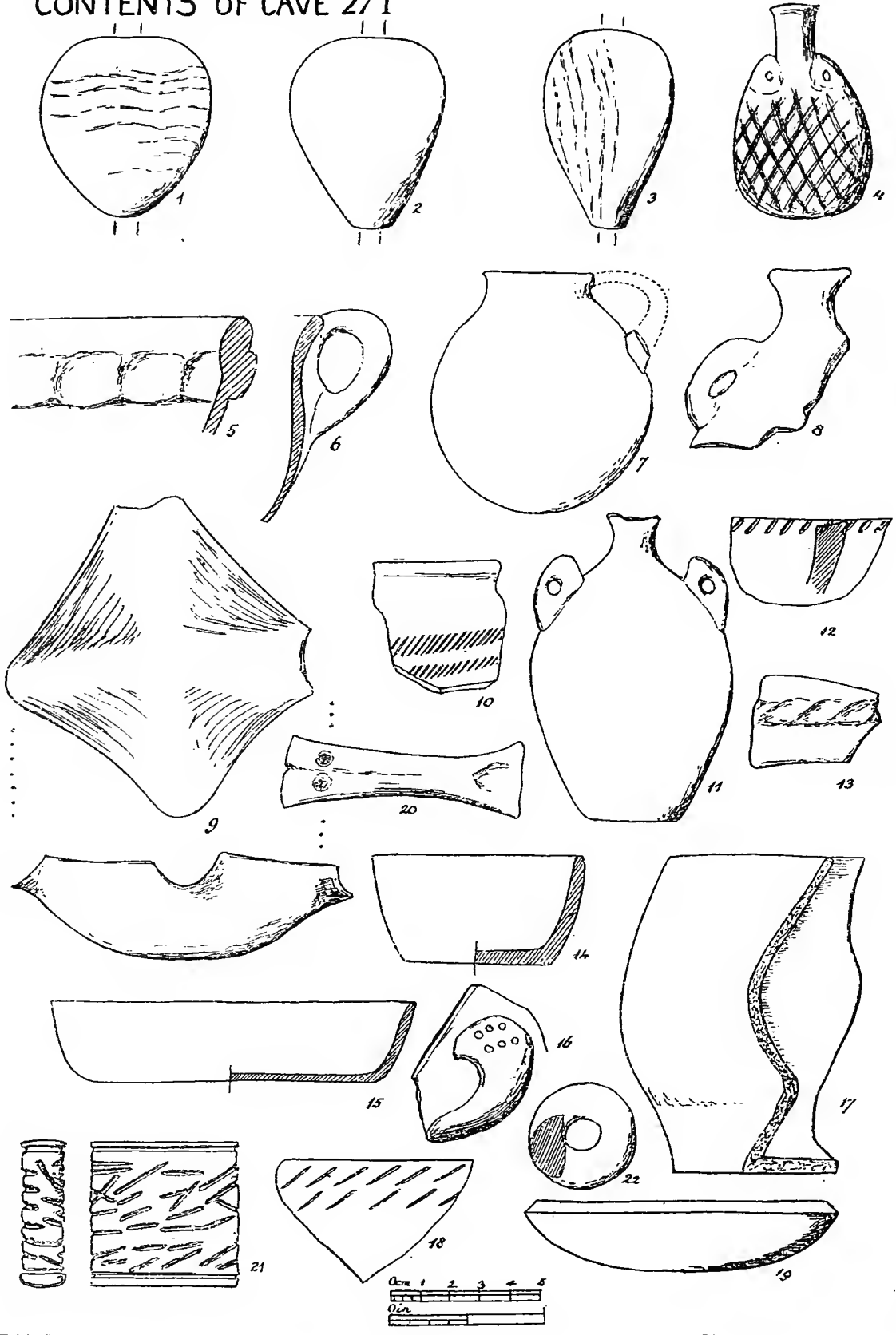

CONTENTS OF CAVES 27I (1,2) & 30III (3-7)

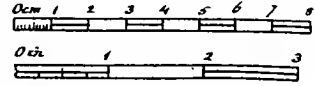

figs. 1, 2, 10/16 scale.

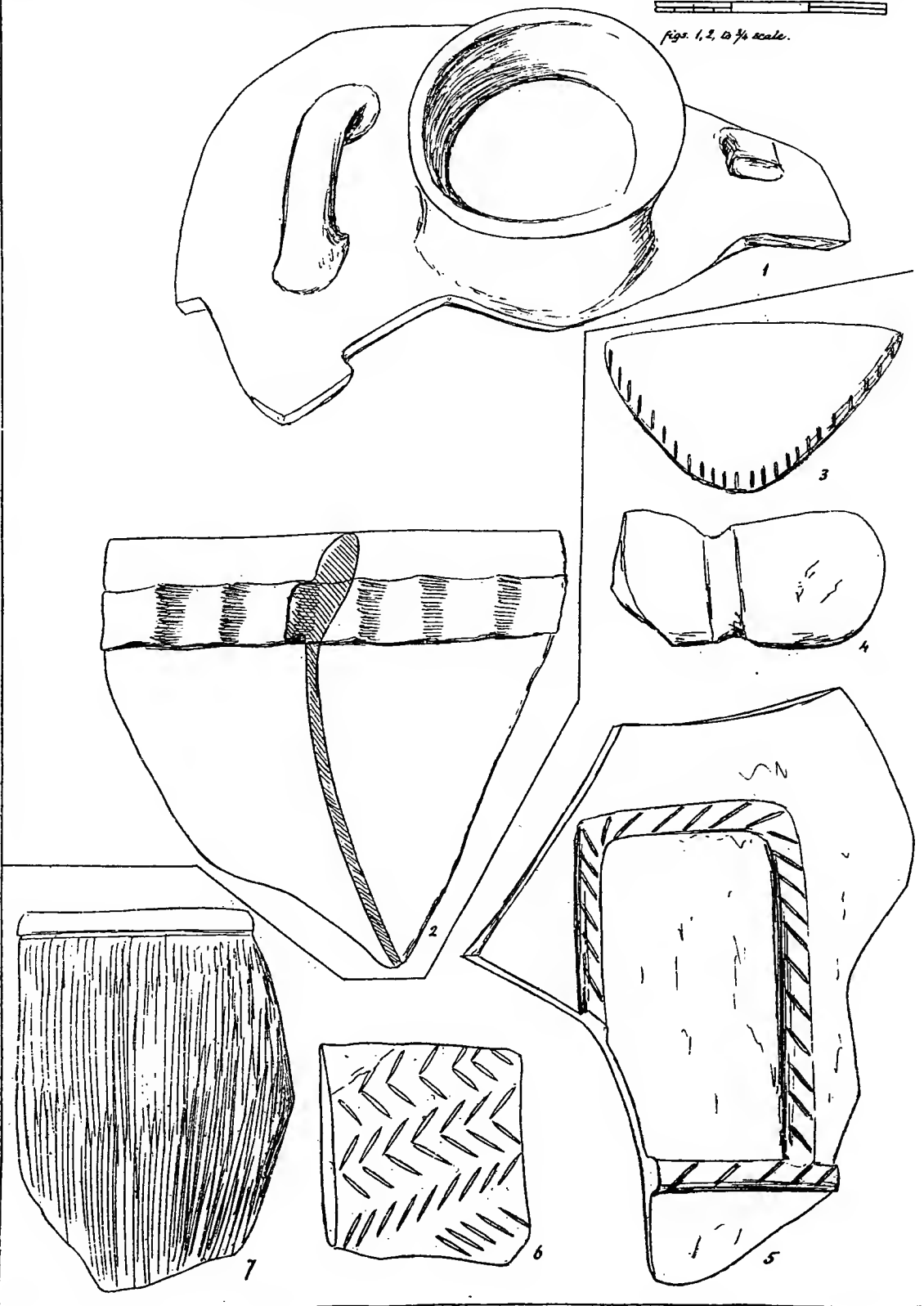





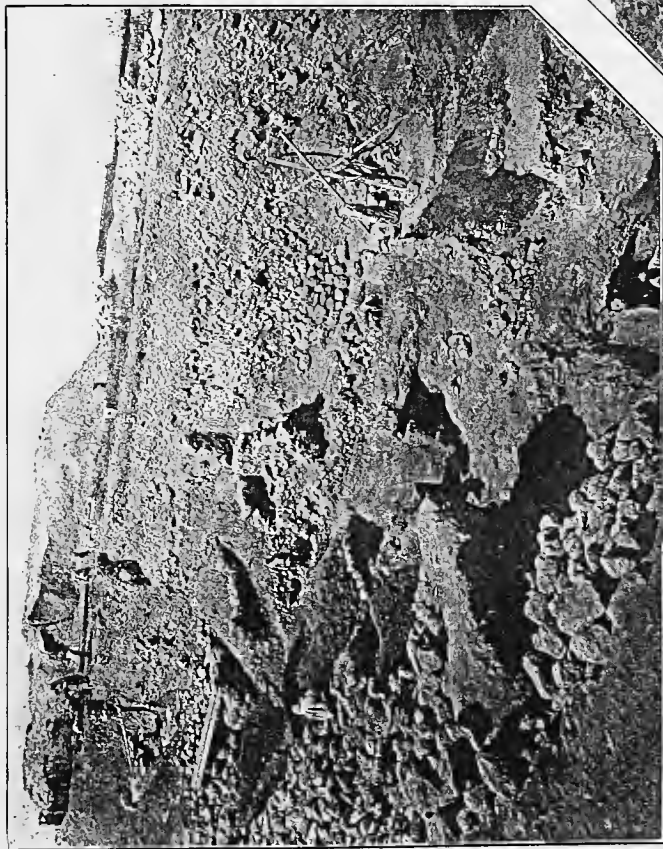
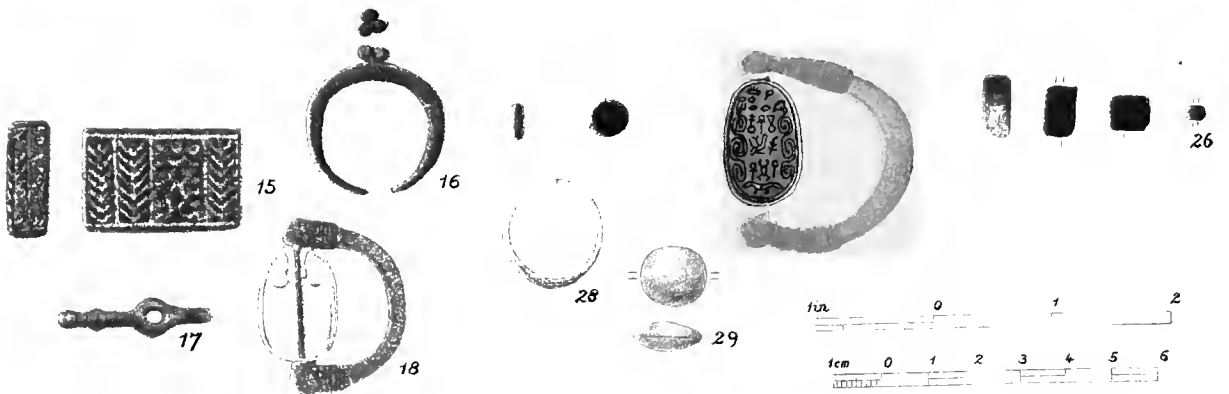
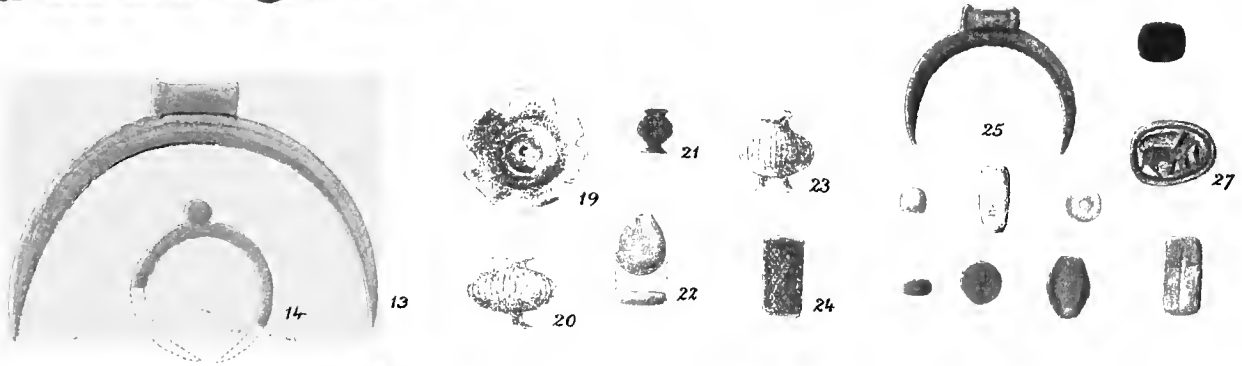

FIG. I



# OBJECTS FROM CHAMBER 6, CAVE 28 II





POTTERY &c FROM *b,d,e*, CAVE 28 II

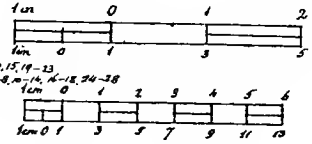

upper figures for 4, 9, 15, 19-23  
 lower figures for 1-3, 5-8, 10, 14, 16-18, 24-38

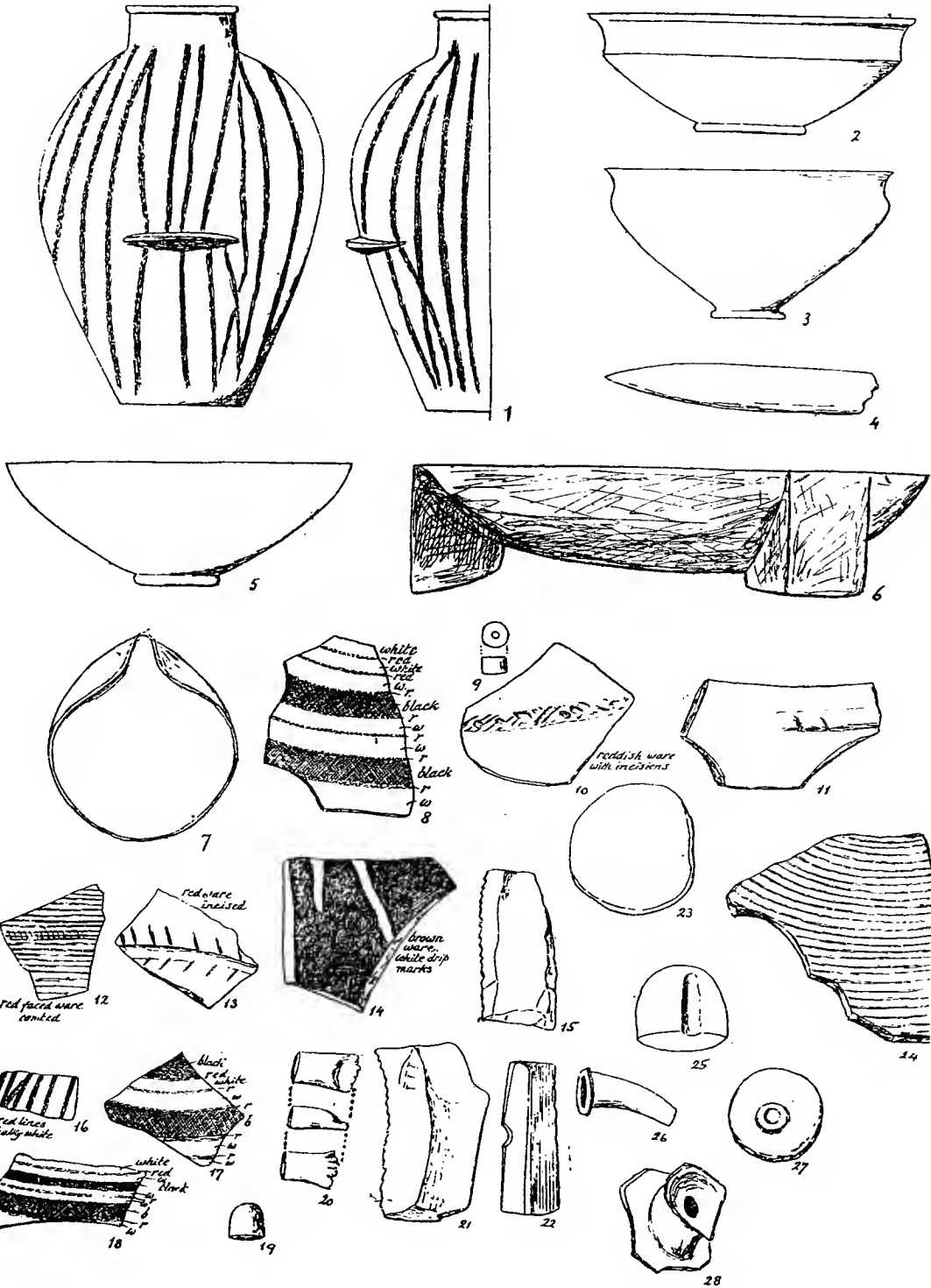







POTTERY FROM THE CISTERN IN CHAMBER(2), CAVE 28 II

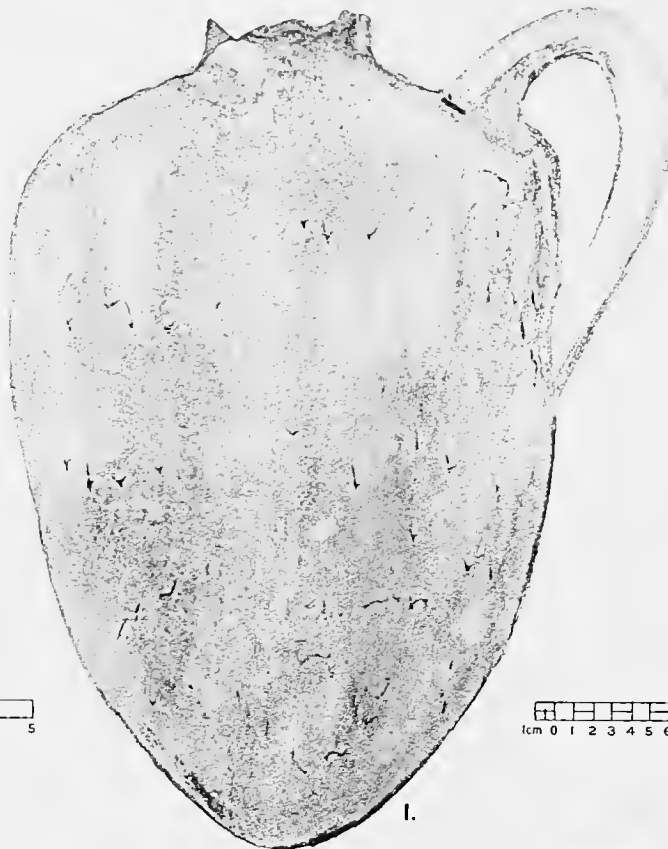
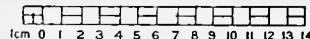
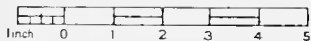

*R. S. Mackenzie*

IVORY &c from CAVE 28 II

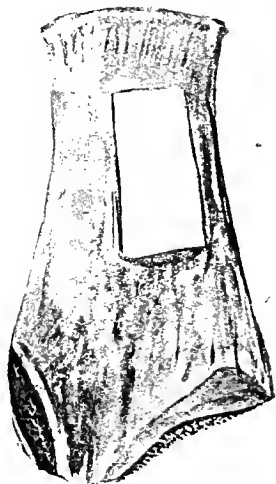
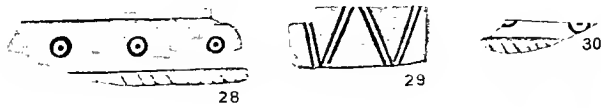
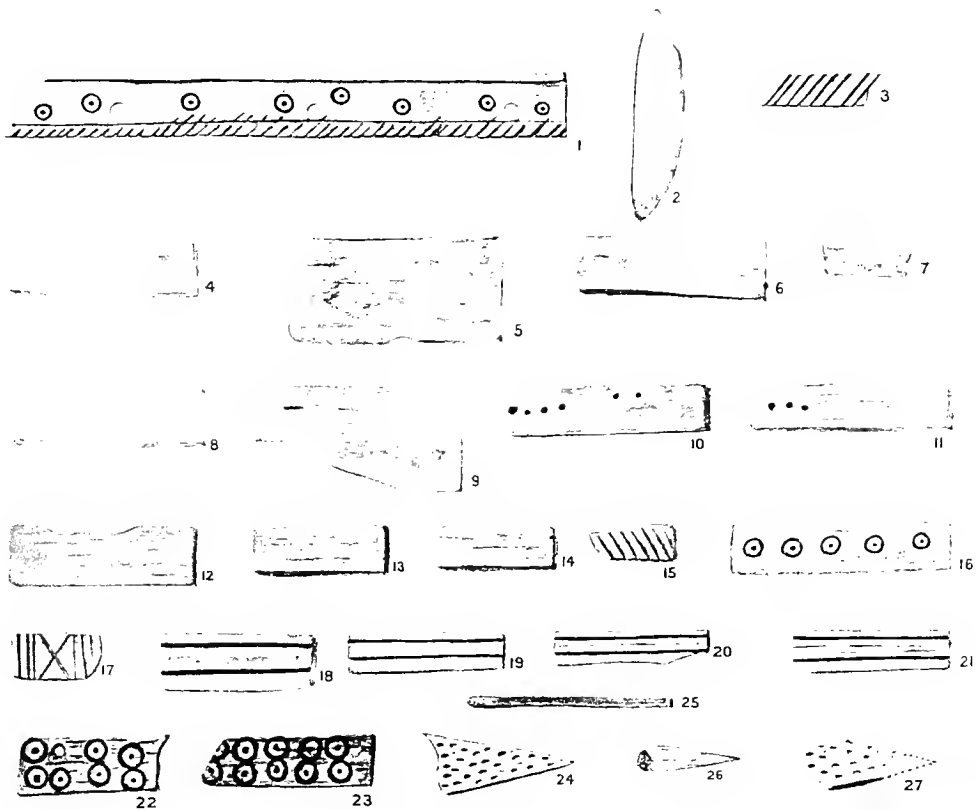

*R. S. S. S. S.*





# SCARABS &c. from CAVE 28 II

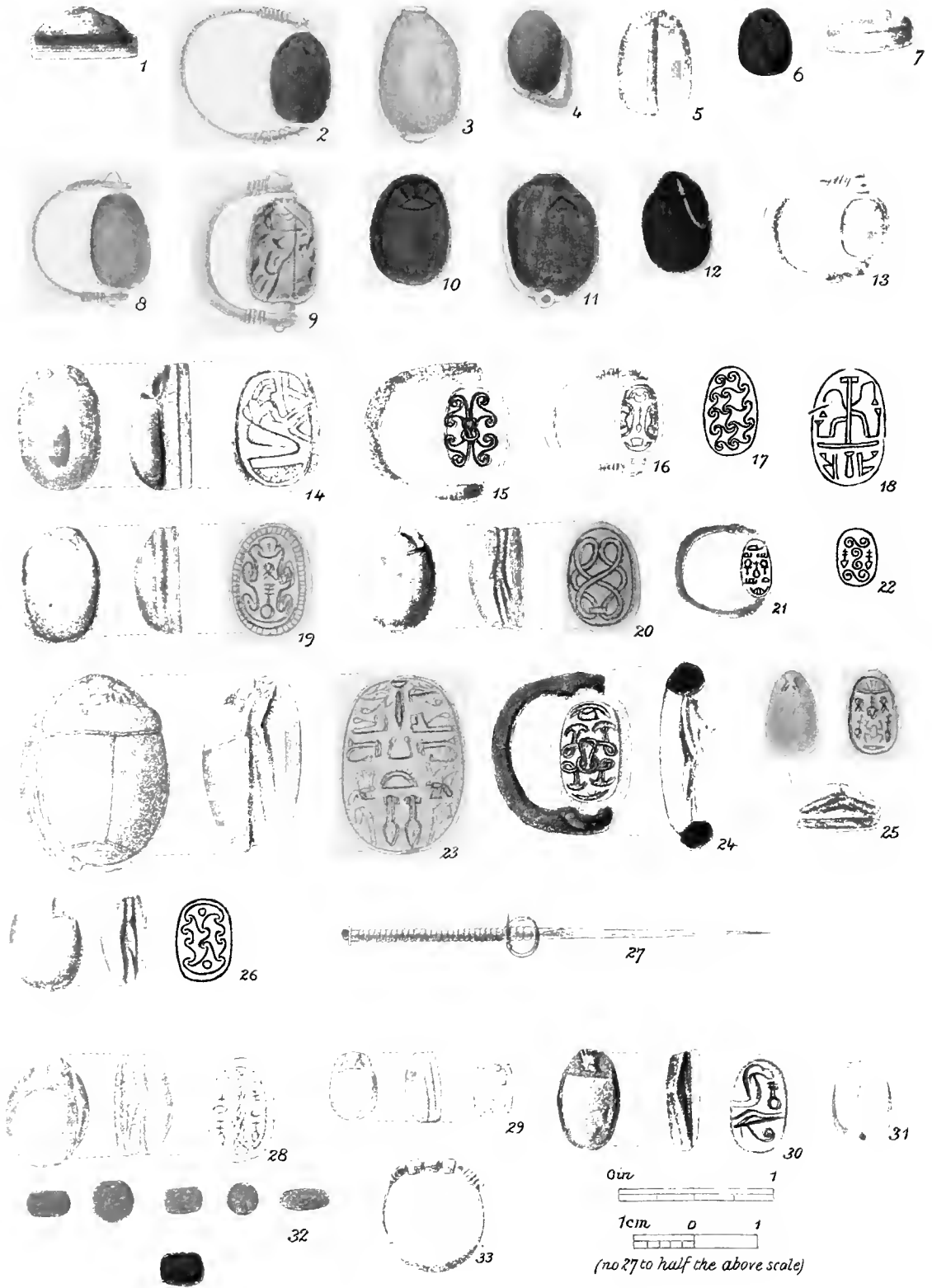

POTTERY &c. from CAVE 28 II

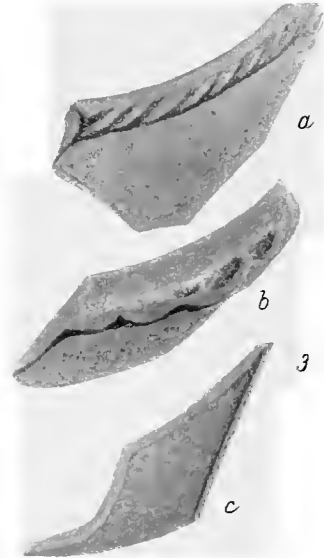
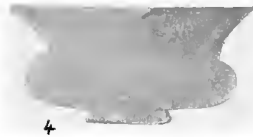
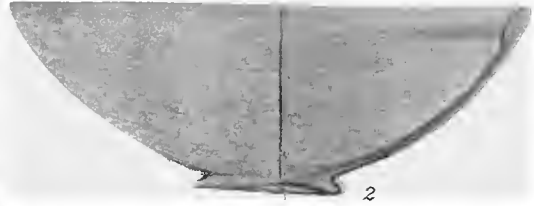
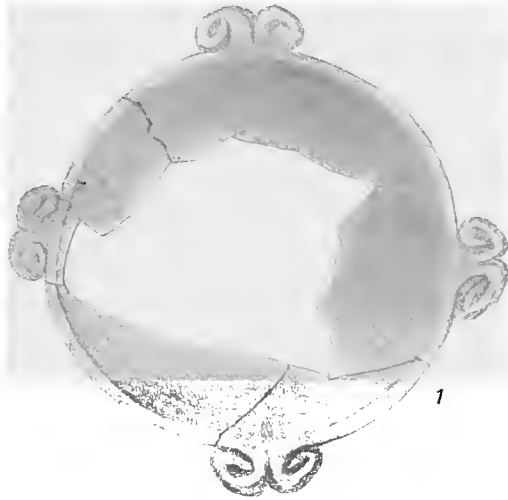

0 in	1	2	3	4	(figs 7-4)	0 cm	2	4	6	8	10	12
0 in	1	2	3	4	(figs 5-9, 12, 13, 17-20)	0 cm	1	2	3	4	5	6
0 in	1/2	1	1 1/2	2	(figs 10, 11, 14 16)	0 cm	1	2	3	4	5	6





POTTERY

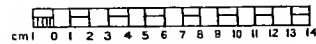
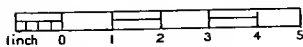

*R. S. Hoopes*







# POTTERY

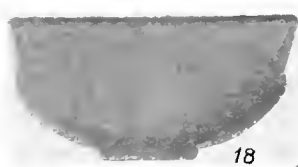
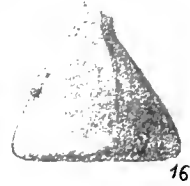
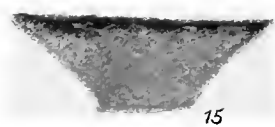
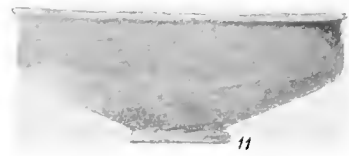
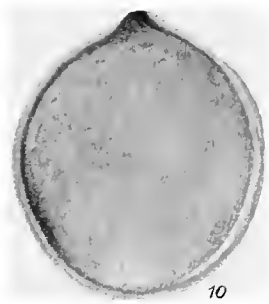
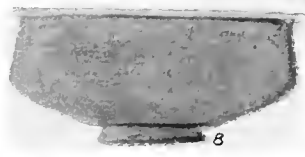
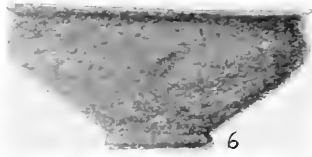
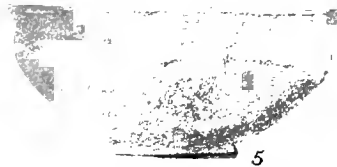
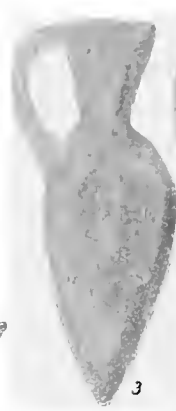

0 1 2 3 4

1cm 0 1 2 3 4 5 6 7 8 9 10 11 12 13 14

# POTTERY

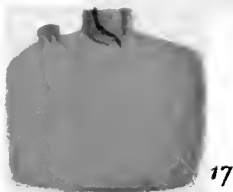
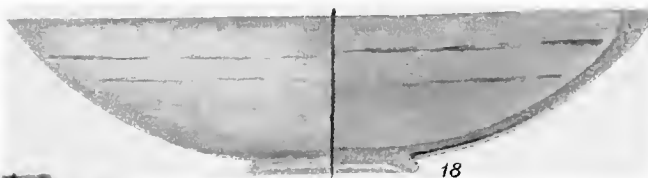
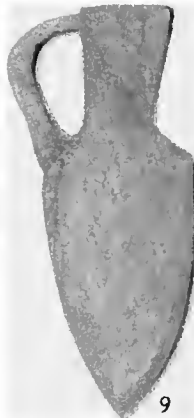
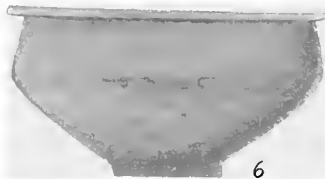
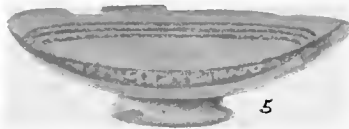
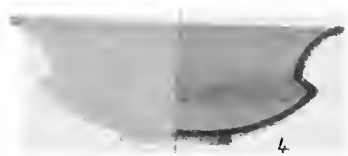
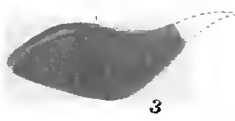
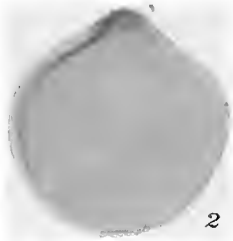

1cm	0	1	2	3	4	5	6	7	8	9
1in	0	1	2	3						





# POTTERY

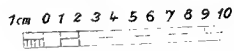
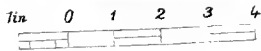
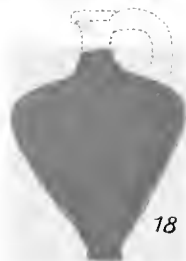
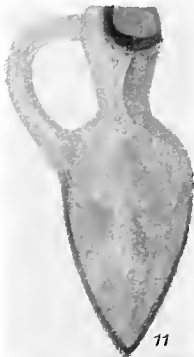

# POTTERY



1

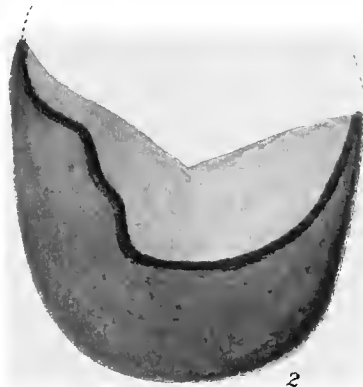

2

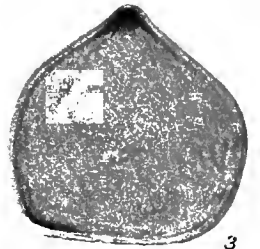

3

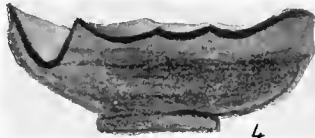

4

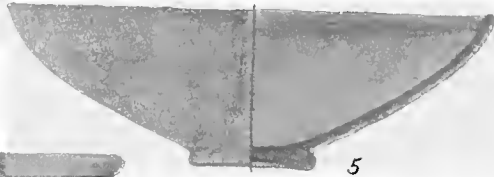

5

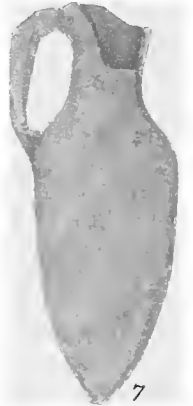

7

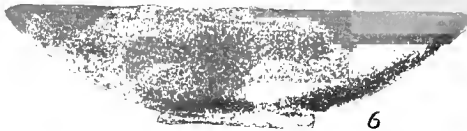

6



8



9

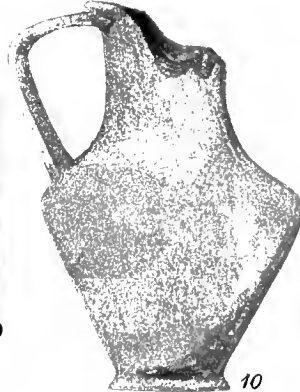

10



11



12



13

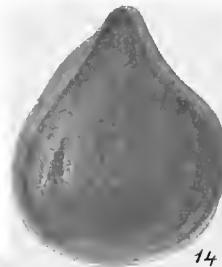

14



16

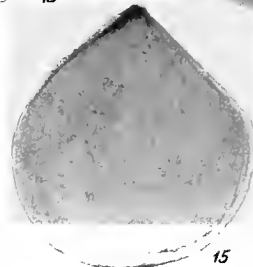

15

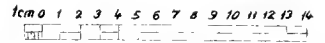
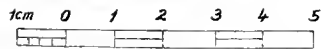





ALABASTER

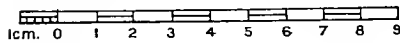
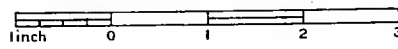
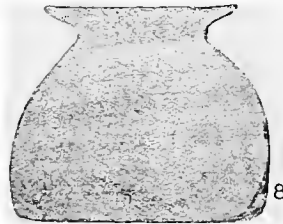
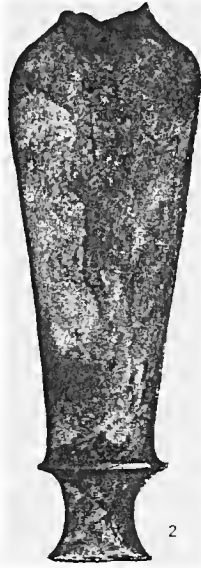
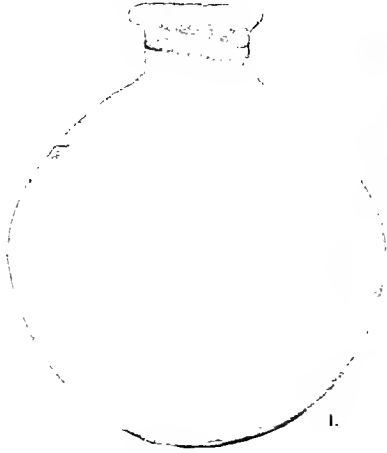

*2802-7/11/12*





# LATER OBJECTS

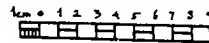
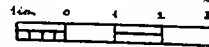
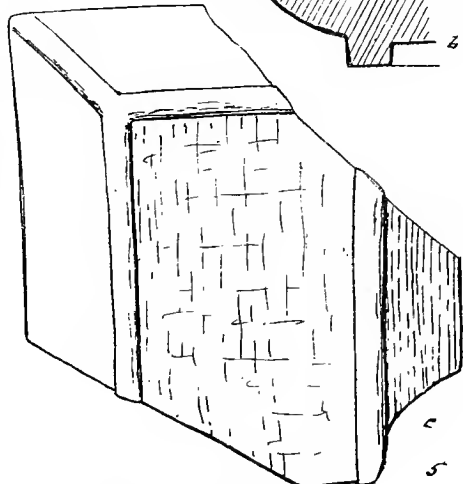
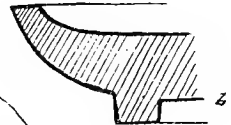
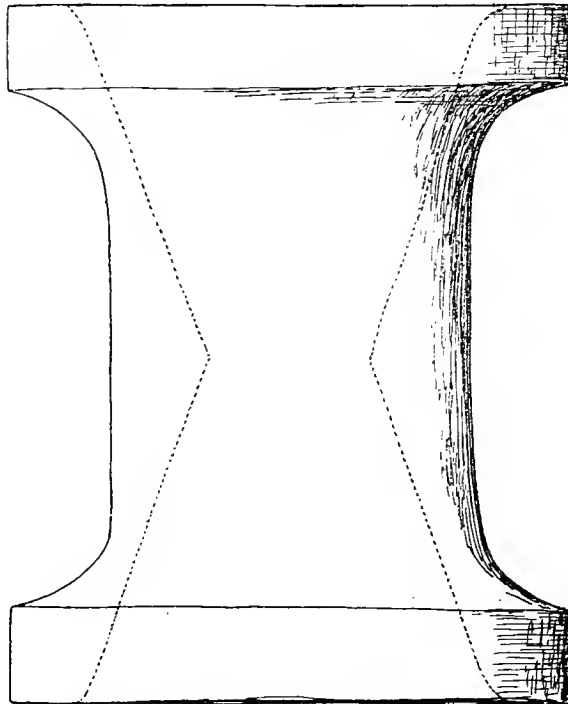
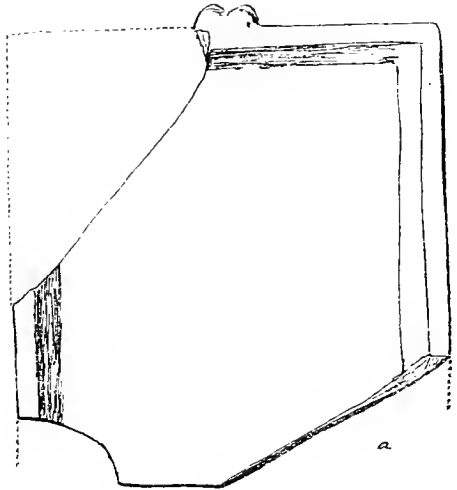
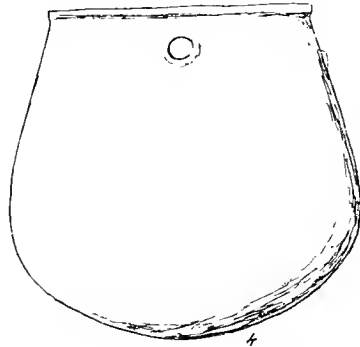
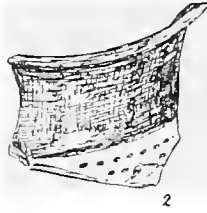
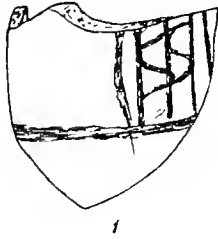

*Richard ...*

CONTENTS OF CAVE 30 II

figs 4,5,10 double, figs 14,15 quadruple scale

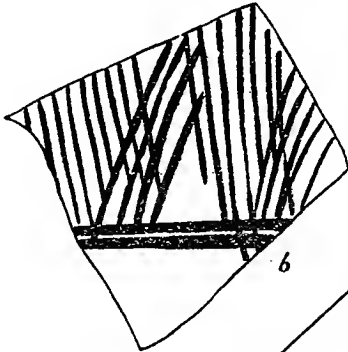
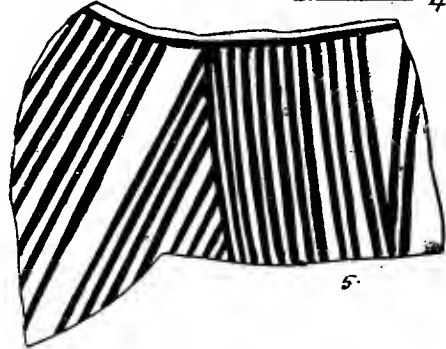
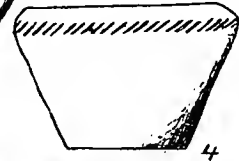
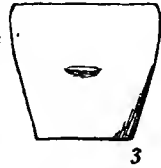
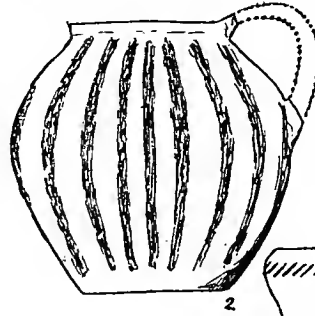
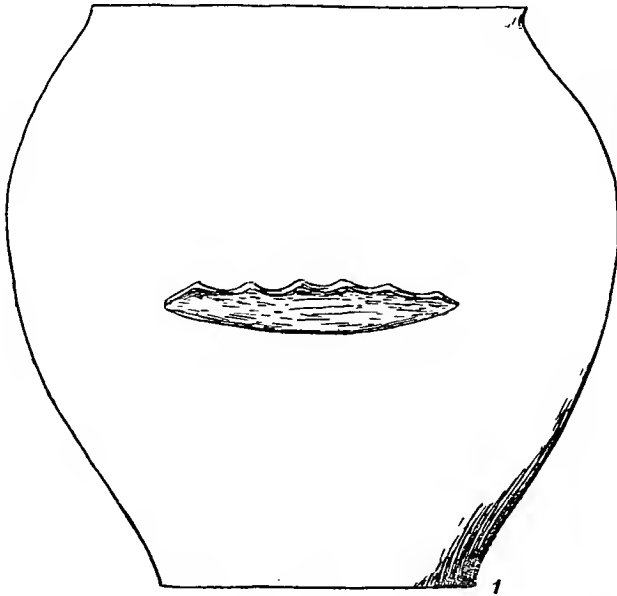
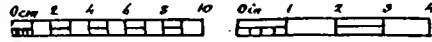

CONTENTS OF CISTERN, S. END TRENCH 30

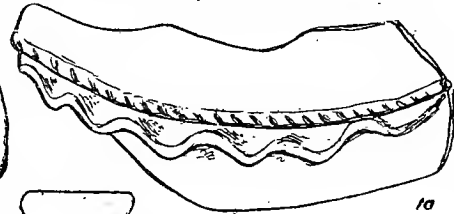
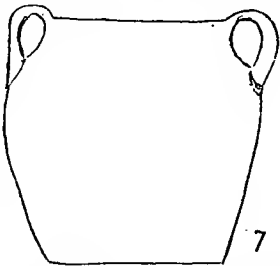

CONTENTS OF CISTERN IN CAVE 14 I

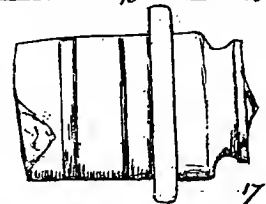
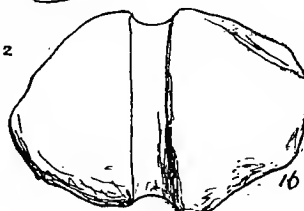
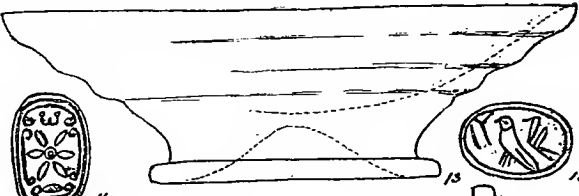
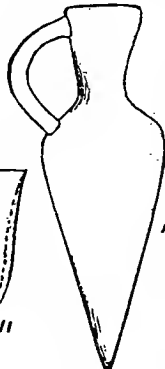
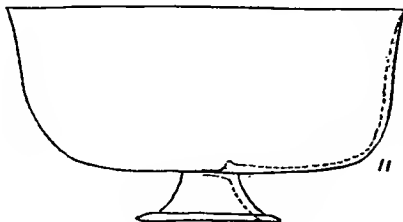



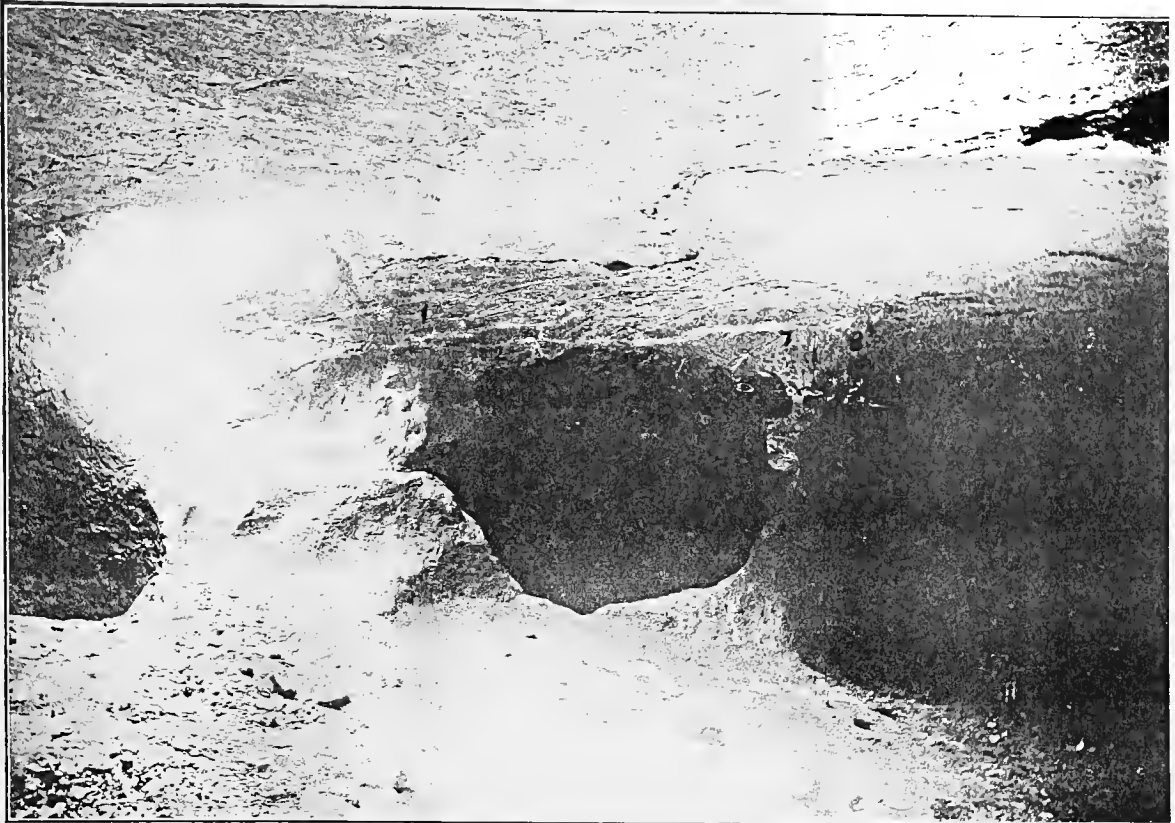

FIG. 1

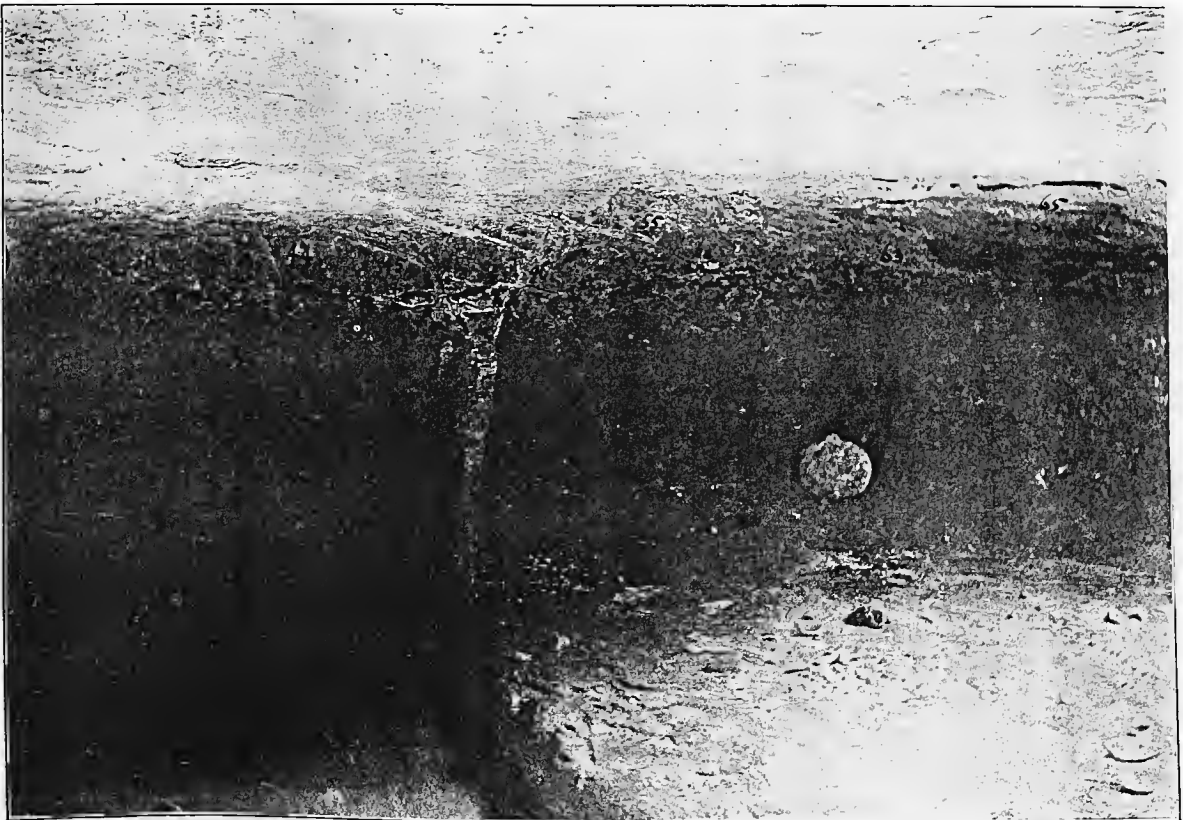

FIG. 2

INTERIOR OF CAVE 30 IV, SHEWING POSITION OF GRAFFITI







CRAFFITI IN CAVE 30 IV

Dim. 1 2 3 4

Dim. 1 2 3 4 5 6

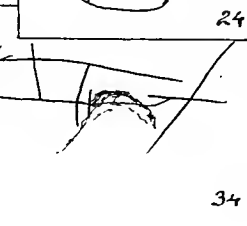
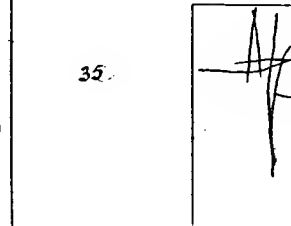
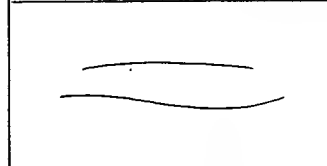
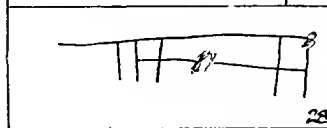
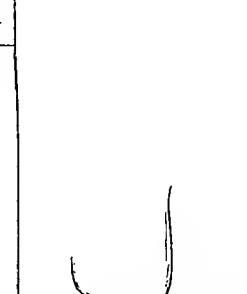
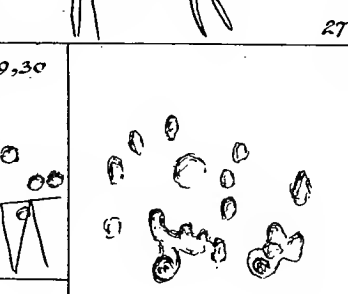
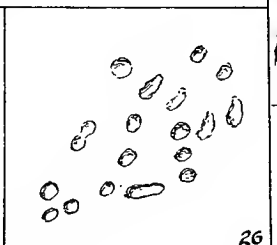
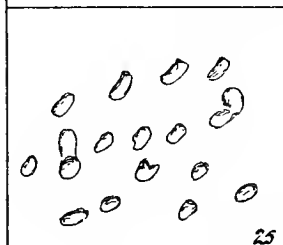
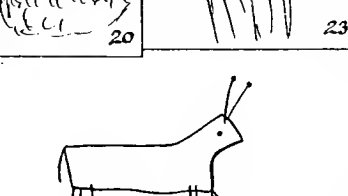
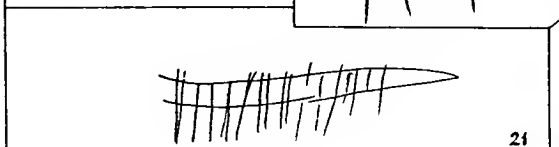
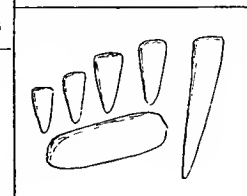
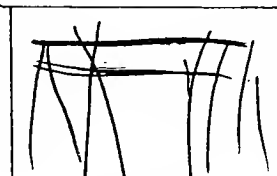
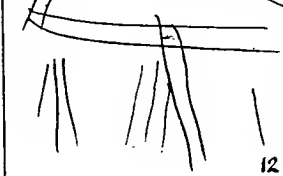
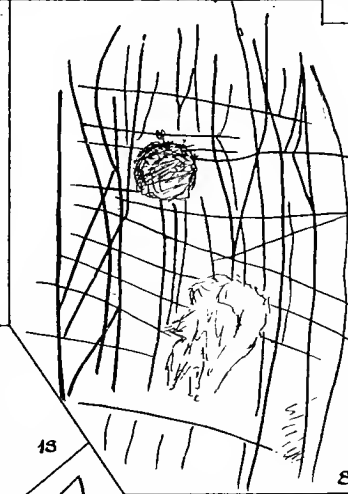
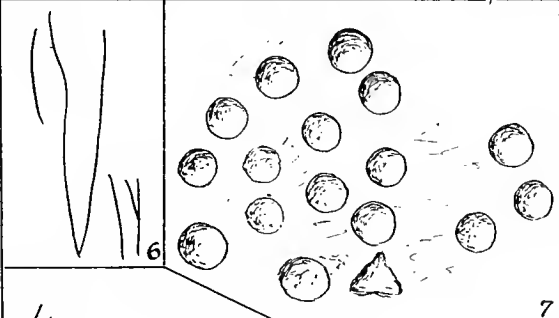
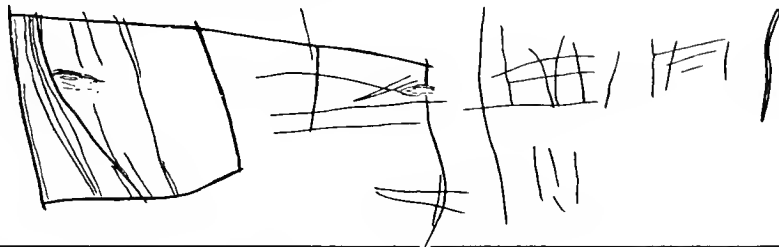

CRAFFITI IN CAVE 30 IV

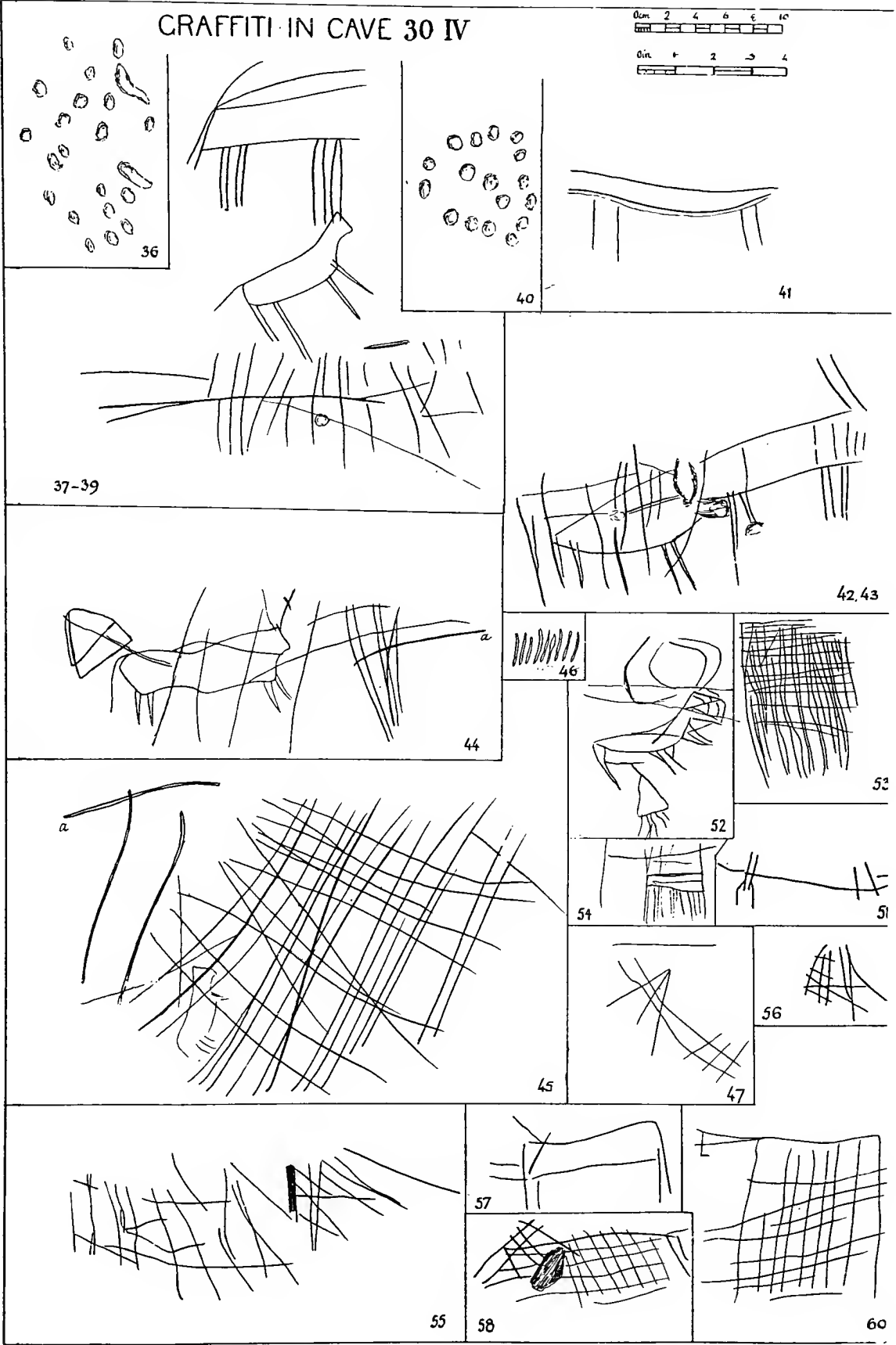
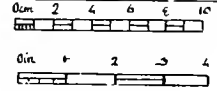





CRAFFITI IN CAVE 30 IV

0cm	2	4	6	8	10
1cm	1	2	3	4	



48-50



61



63

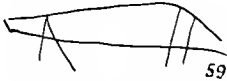

59



64

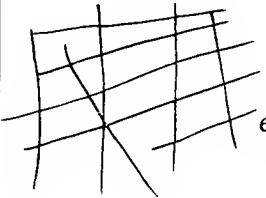

65



66

FROM CAVE 7 II

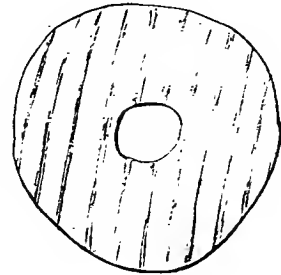
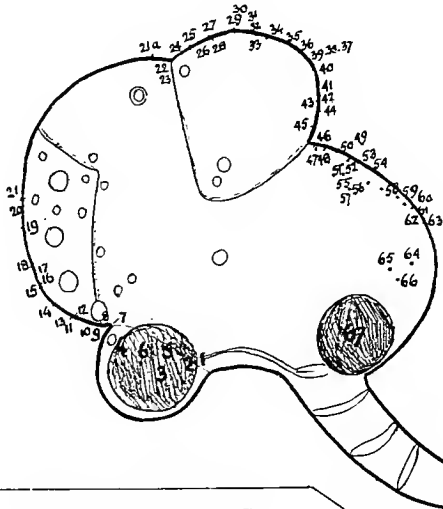

FROM CAVE 6 I

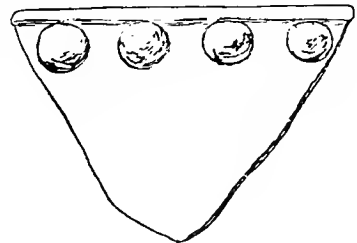

HOUSE PLANS

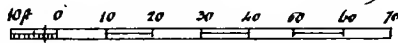
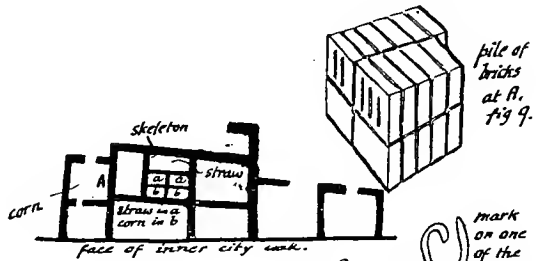
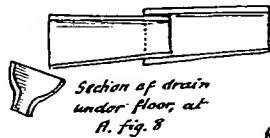
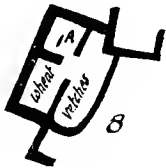
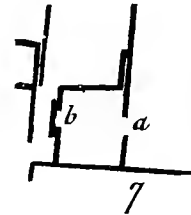
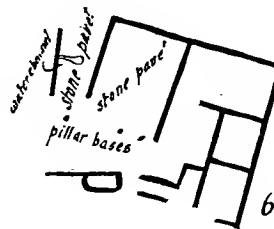
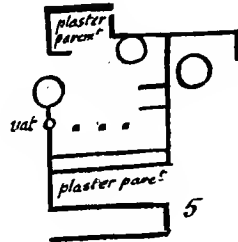
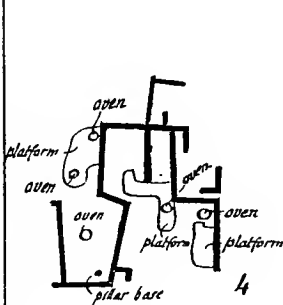
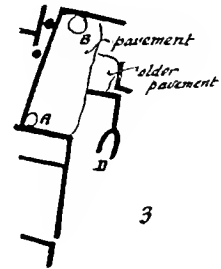
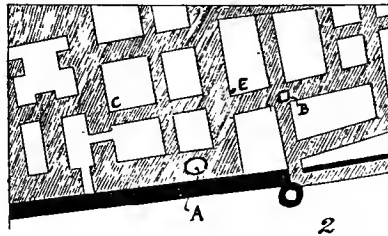
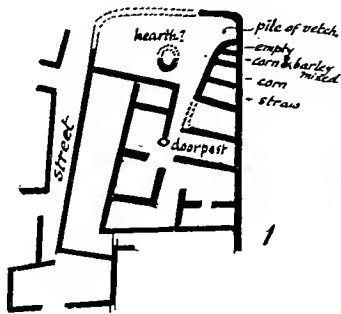





# EXCAVATION OF CEZER

## PLAN OF THE NORTH EAST GATE

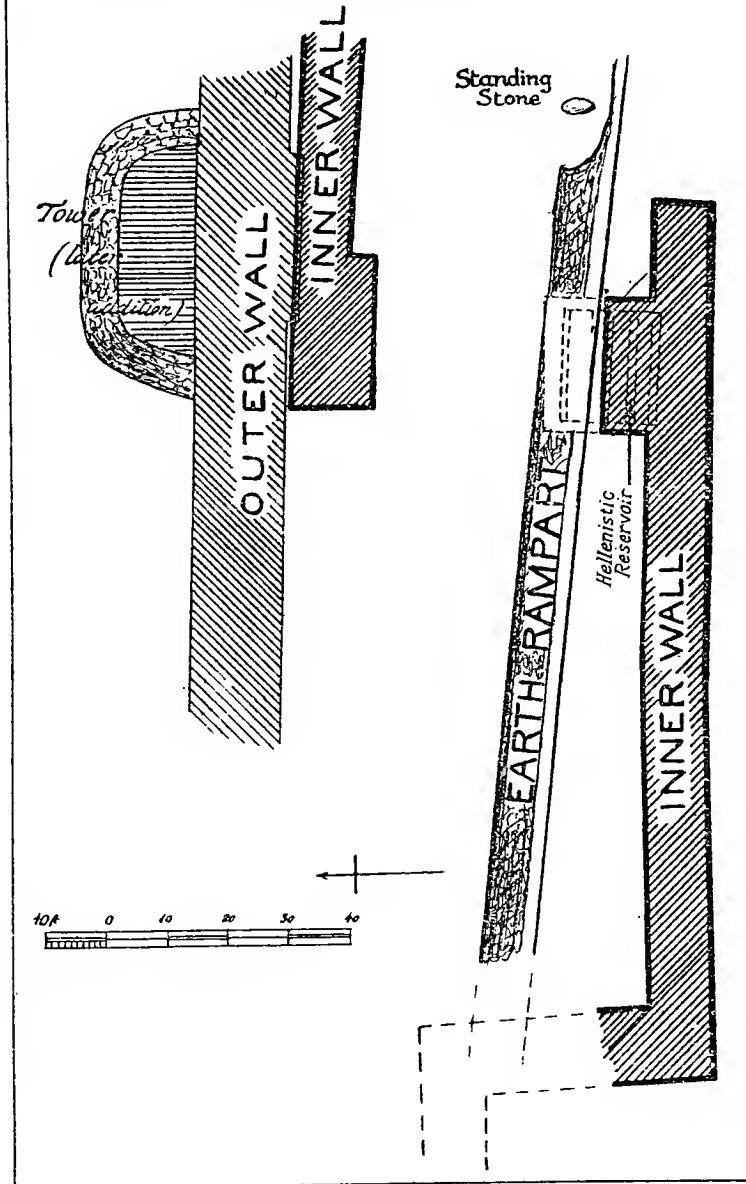





# EXCAVATION OF CEZER FRAGMENTS OF MOULDINGS

8c.

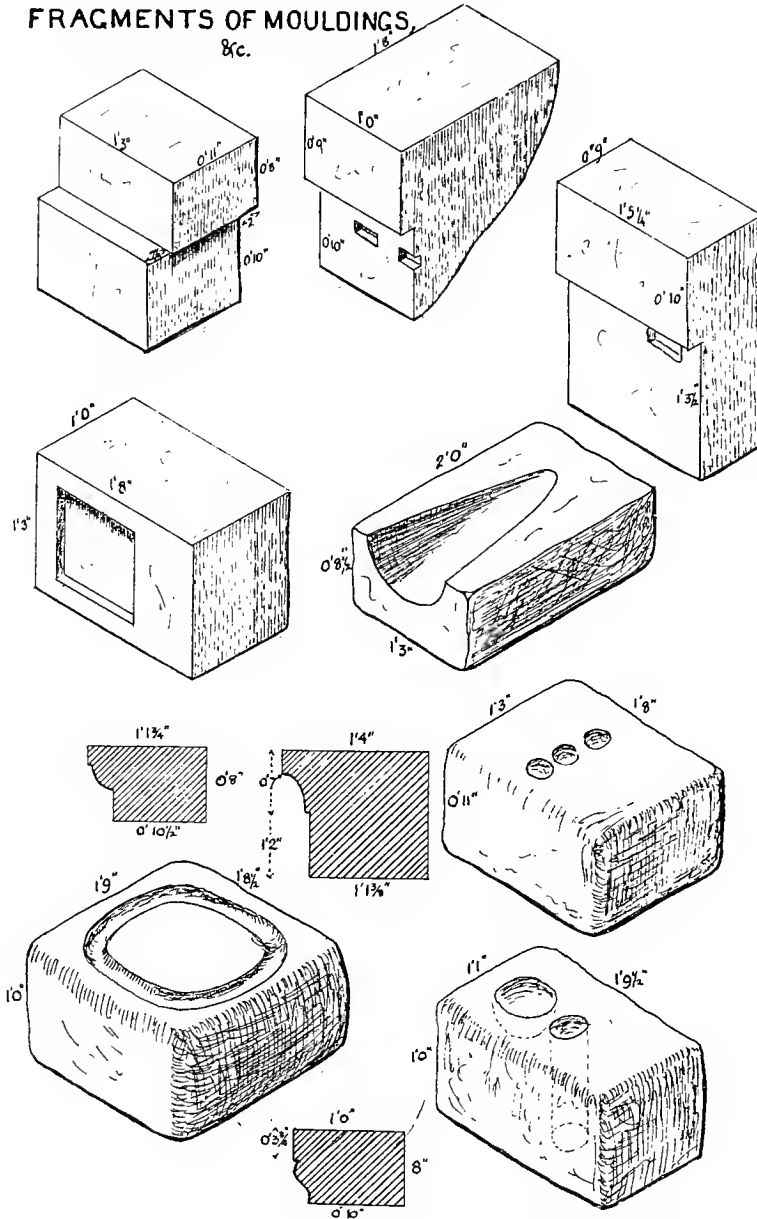

*R. A. ...*

# RESERVOIR

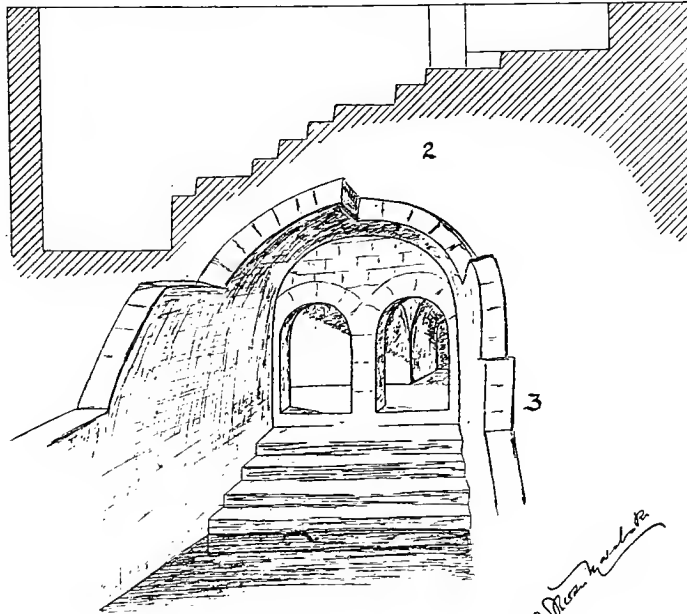
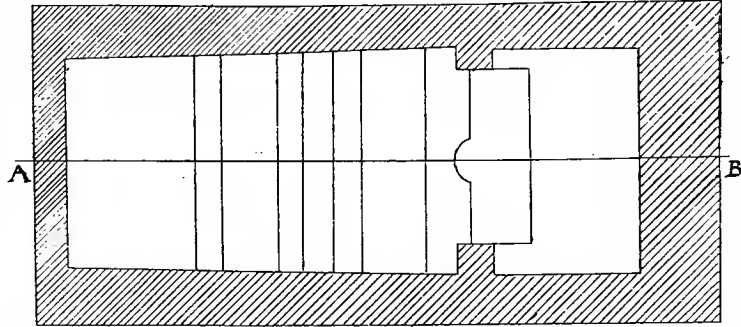
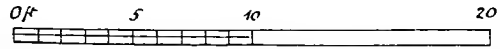

1. Plan of no. I
2. Section . . . on line AB
3. Restoration of no. II

*Restoration of no. II*







"PHILISTINE" TOMB DEPOSITS

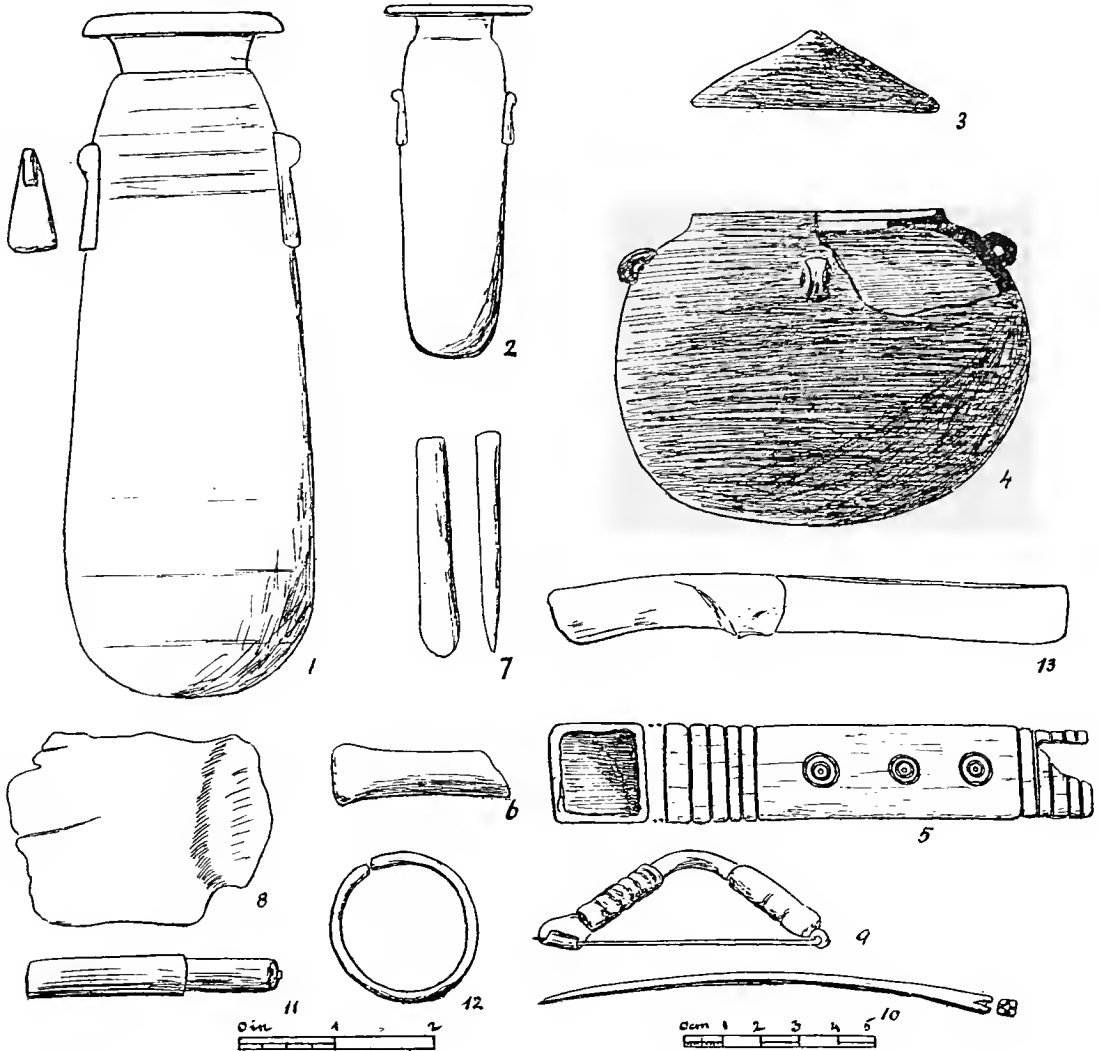

TOMB PLANS

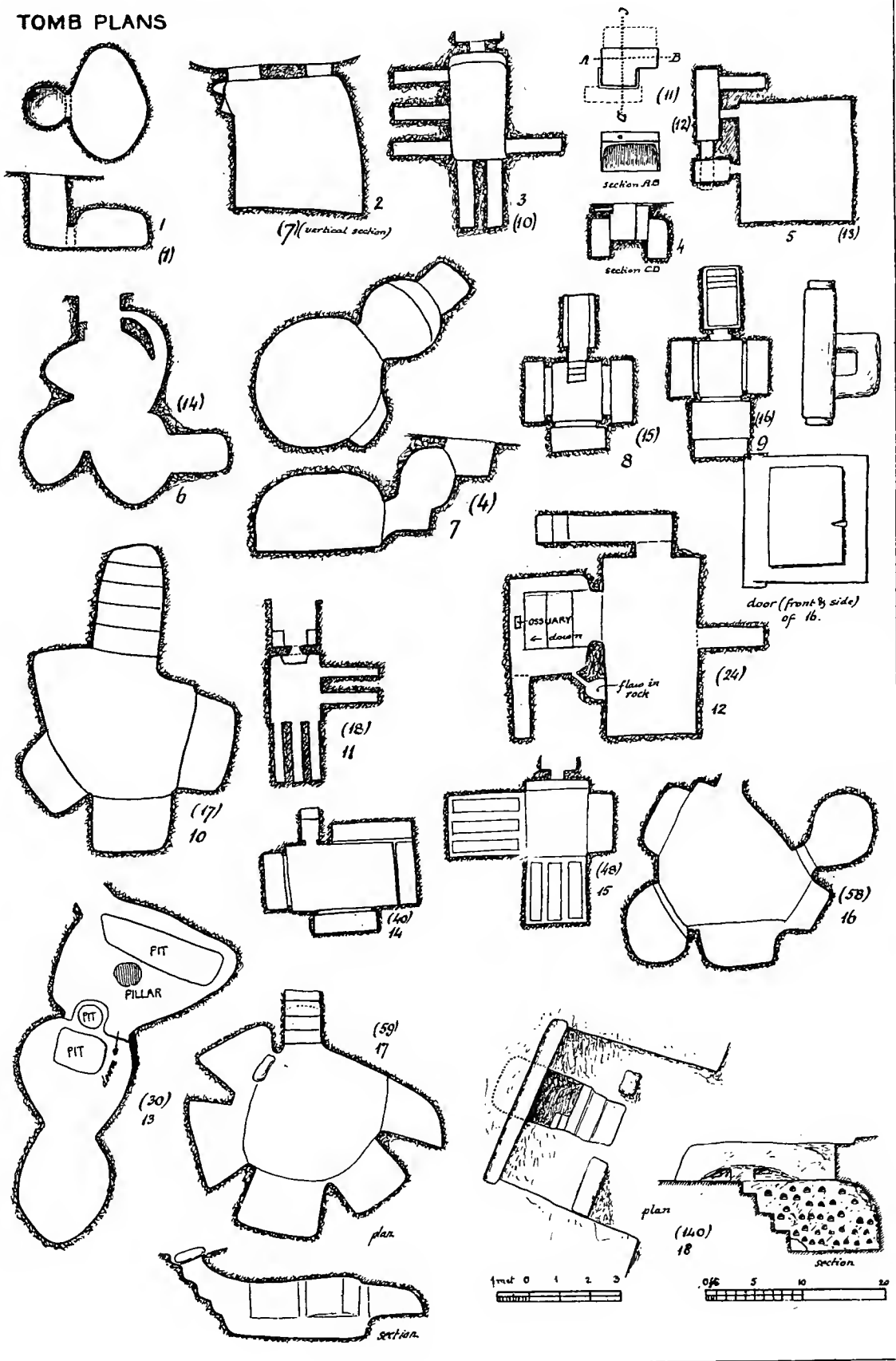





TOMB PLANS

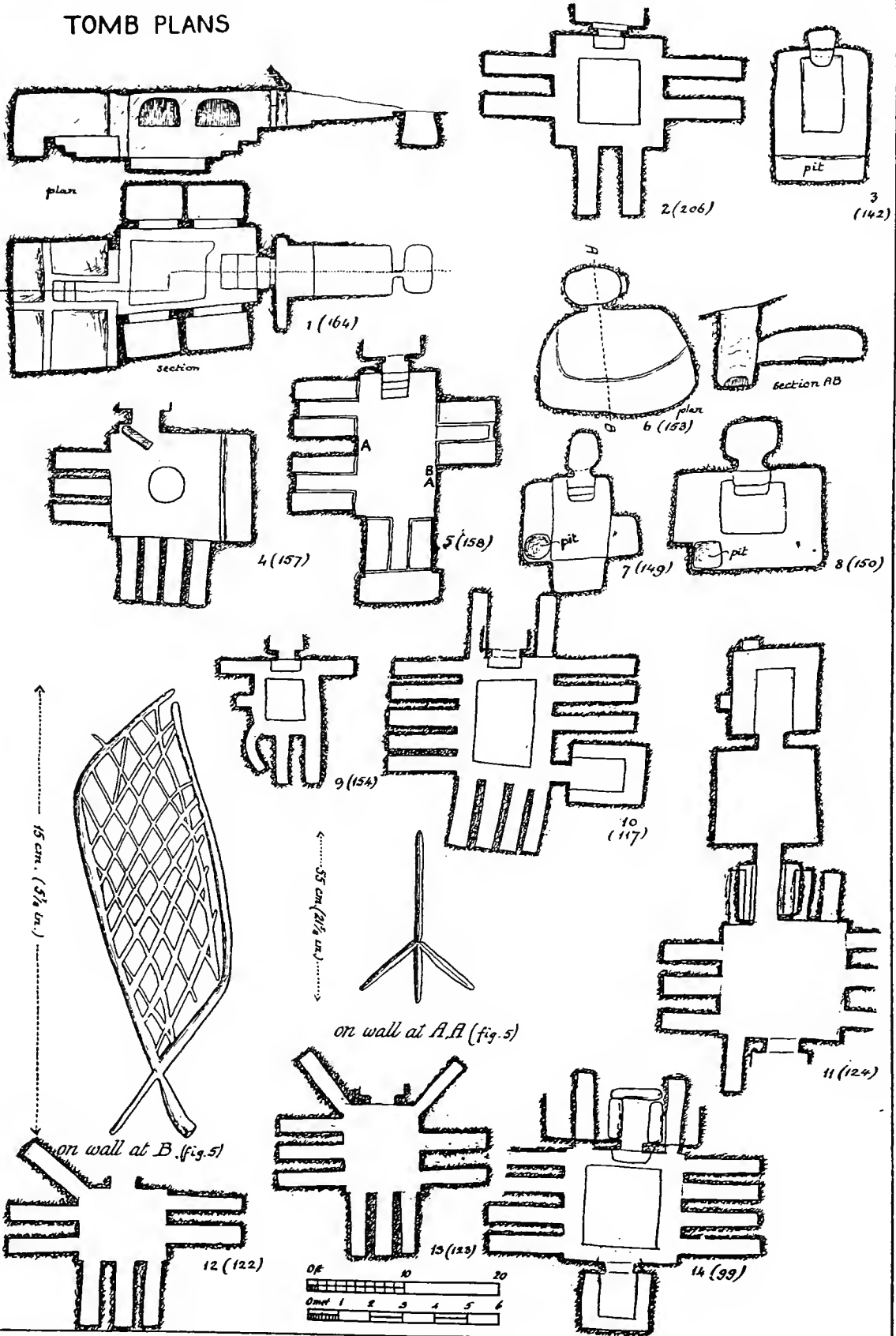

TOMB - PLANS

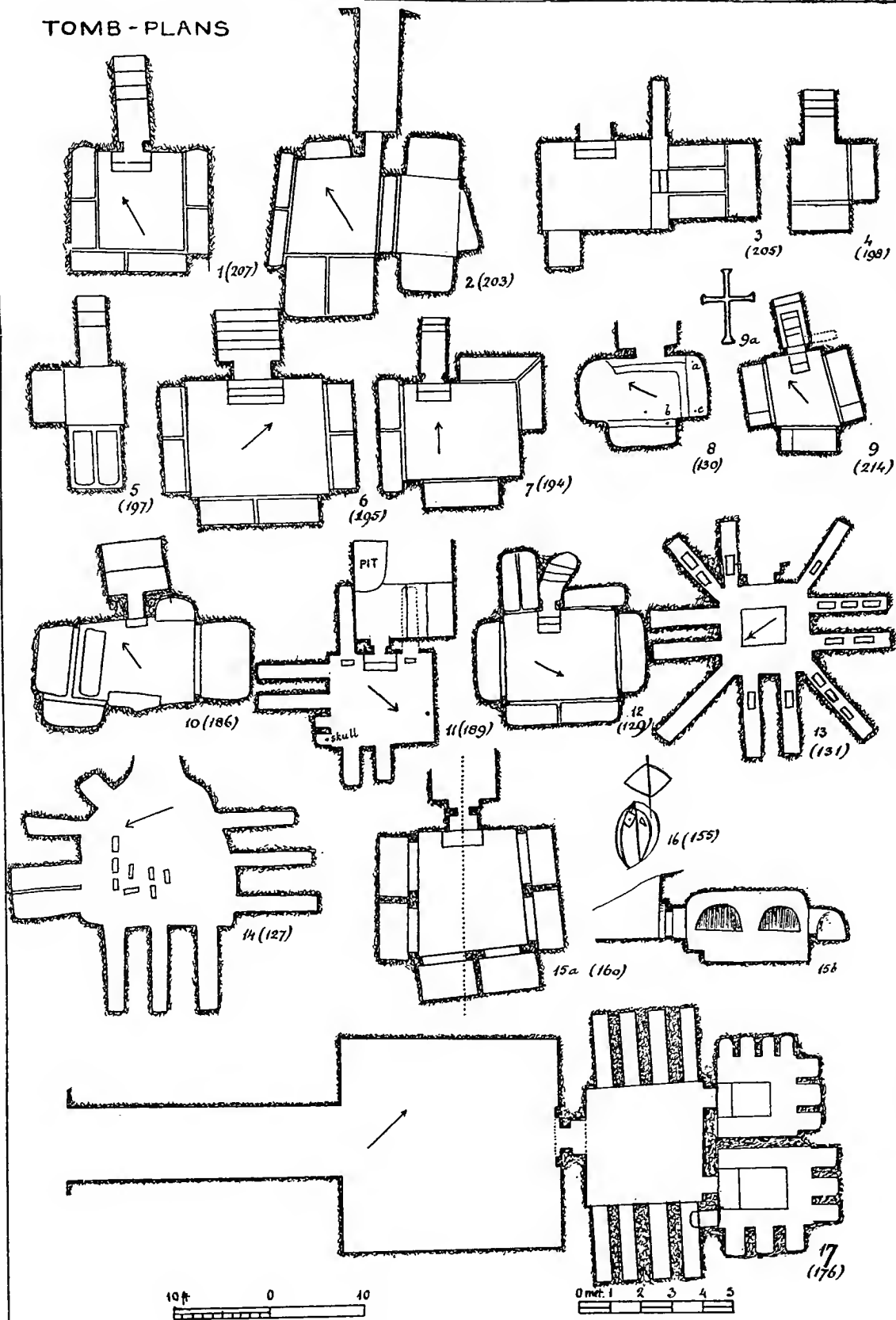







# TOMB PLANS

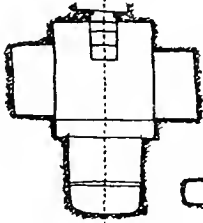

plan 1

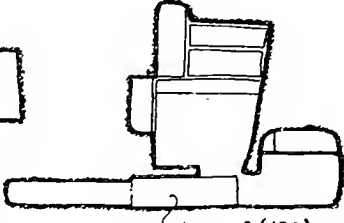

entrance 2 (182)

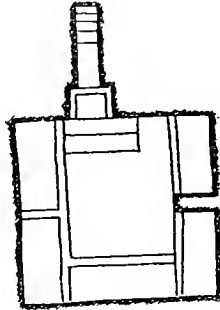

3 (174)

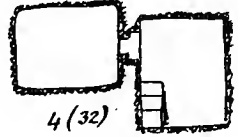

4 (32)

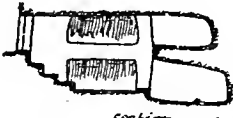

section 1 (223)



5 (83)

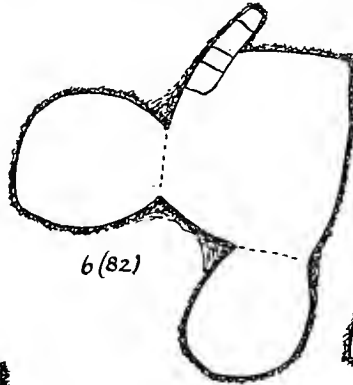

6 (82)

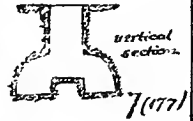

vertical section 7 (177)

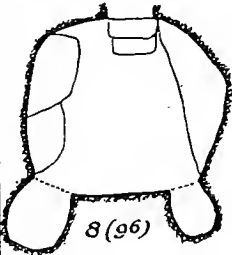

8 (96)

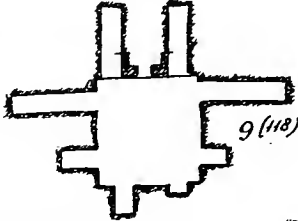

9 (112)

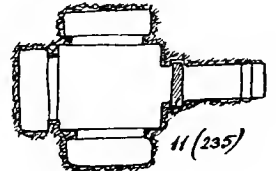
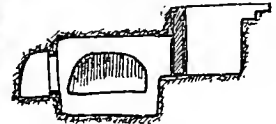

11 (235)

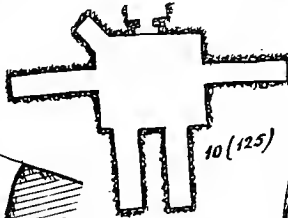

10 (125)

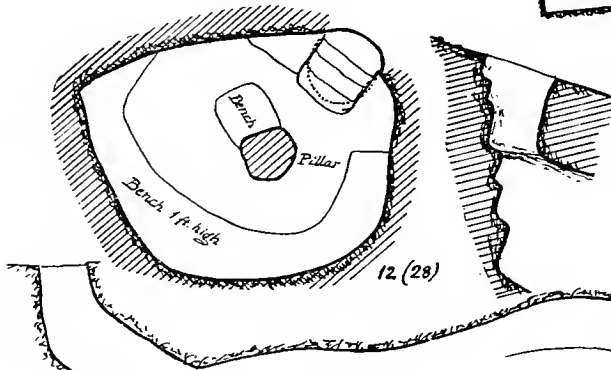

12 (28)

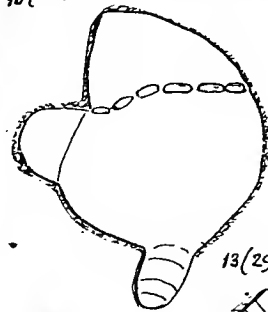

13 (29)

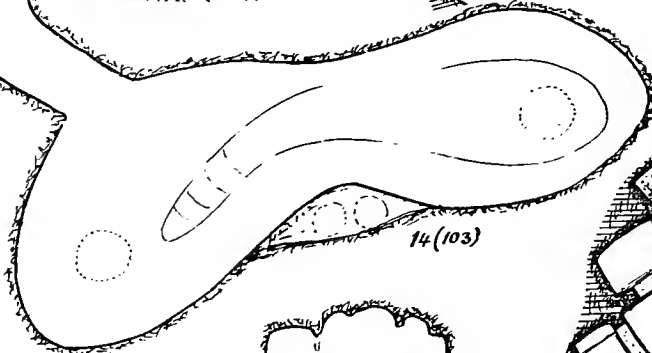

14 (103)

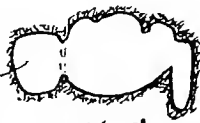

Entrance from roof

16 (226)

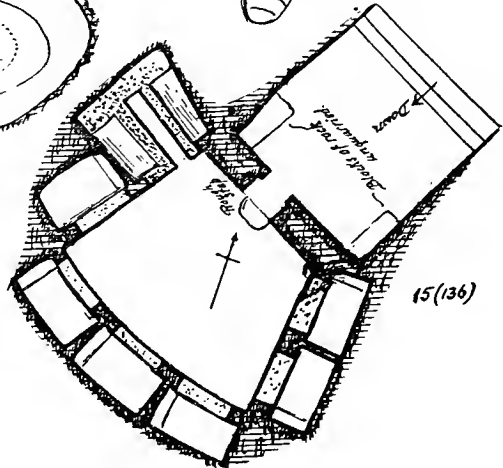

15 (136)

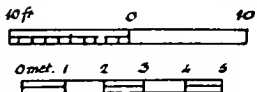

TOMB No 1

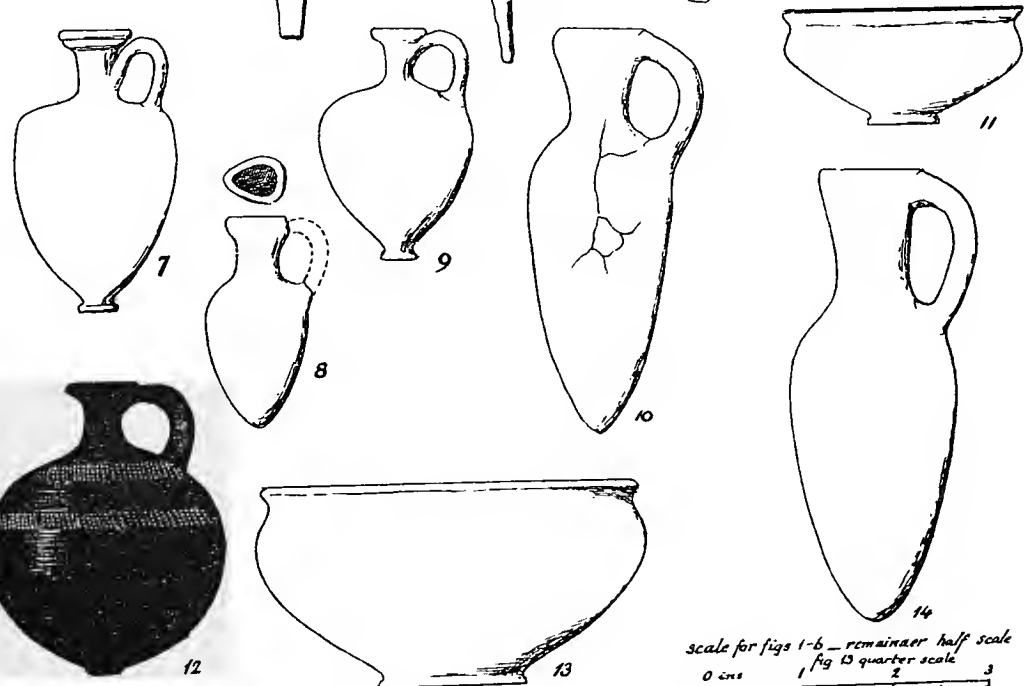
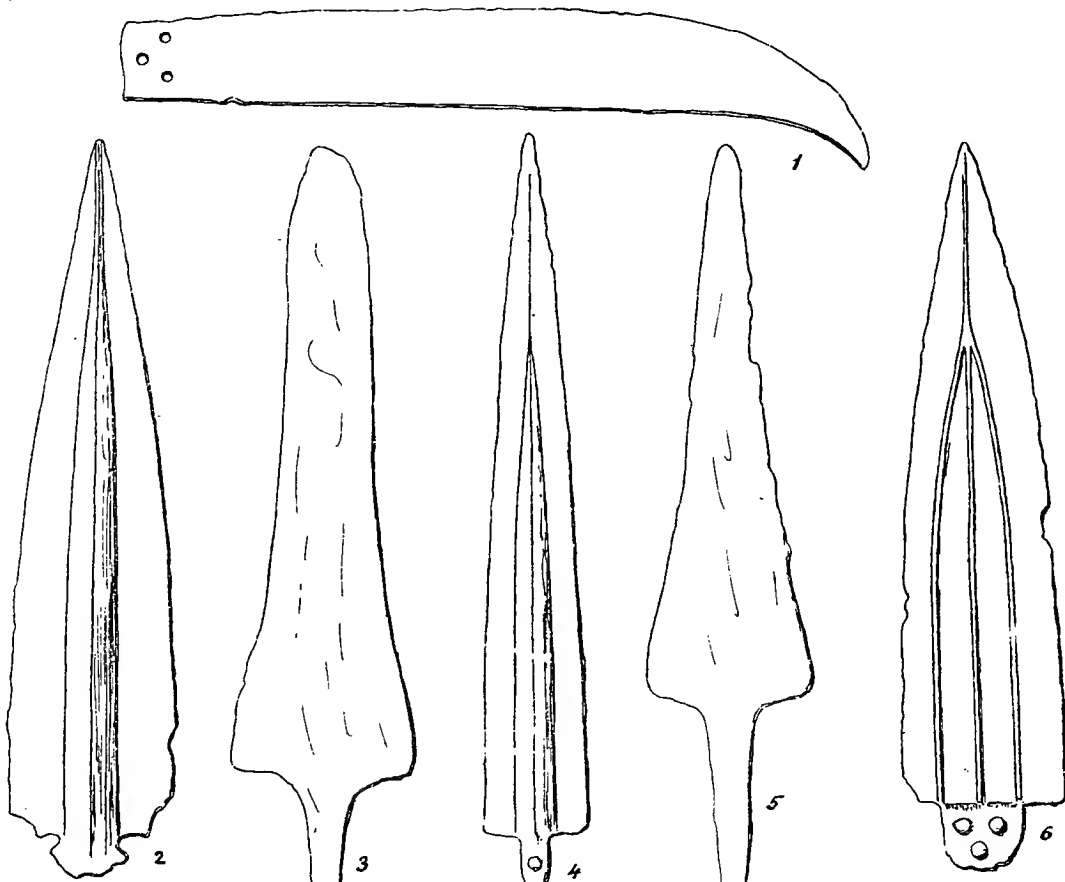

scale for figs 1-6 - remainder half scale  
1 fig 13 quarter scale  
0 cm 1 2 3  
0 cm 1 2 3 4 5 6 7





TOMB No I

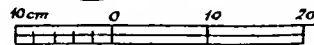
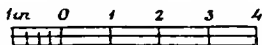
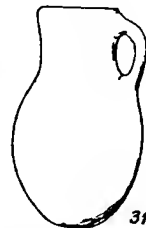
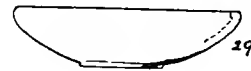
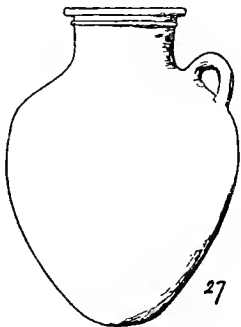
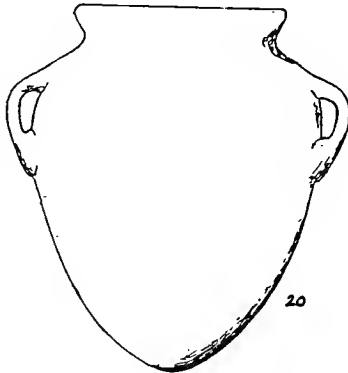
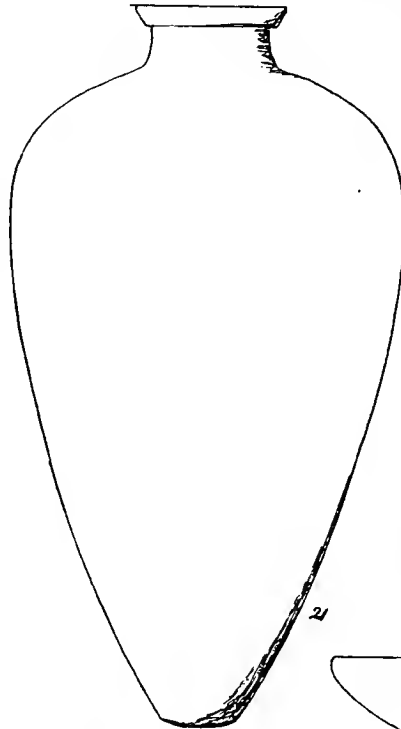
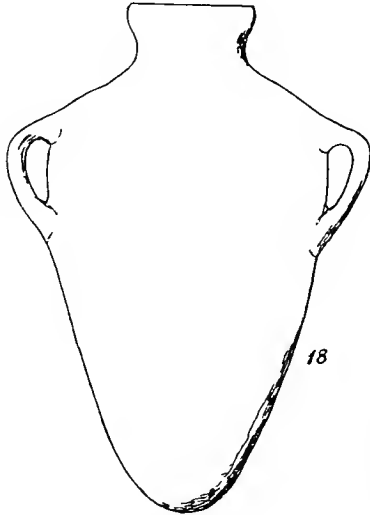
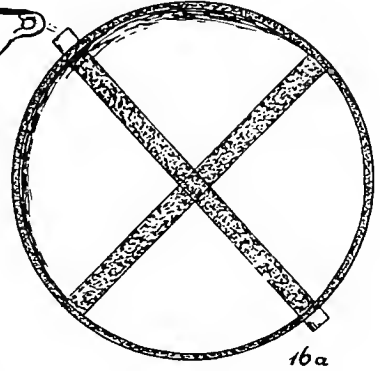
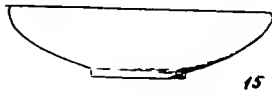

TOMB No I

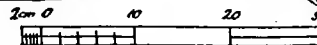
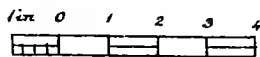
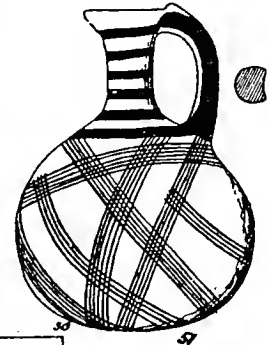
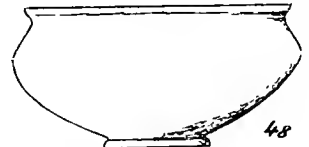
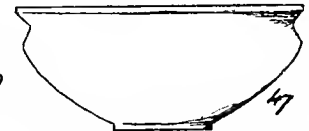
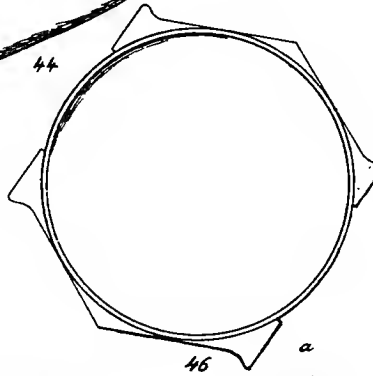
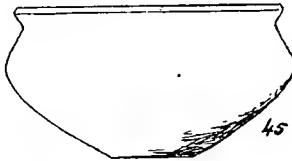
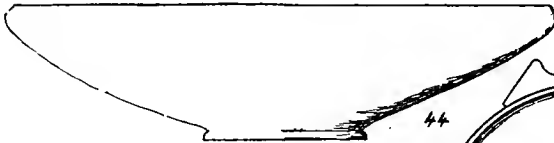
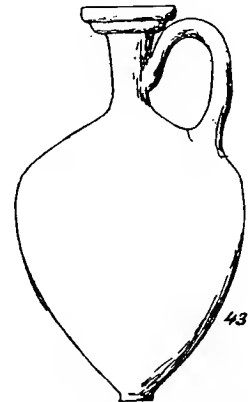
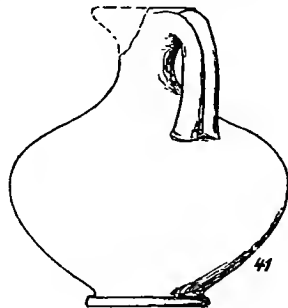
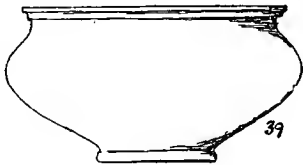
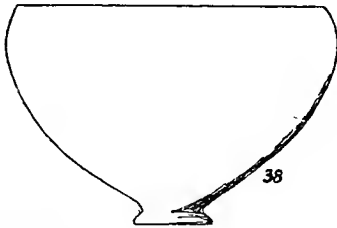
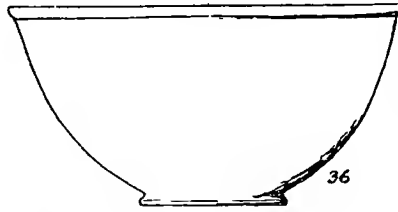
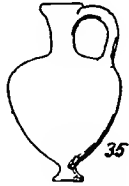

fig. 46 to half the scale







# TOMB No I

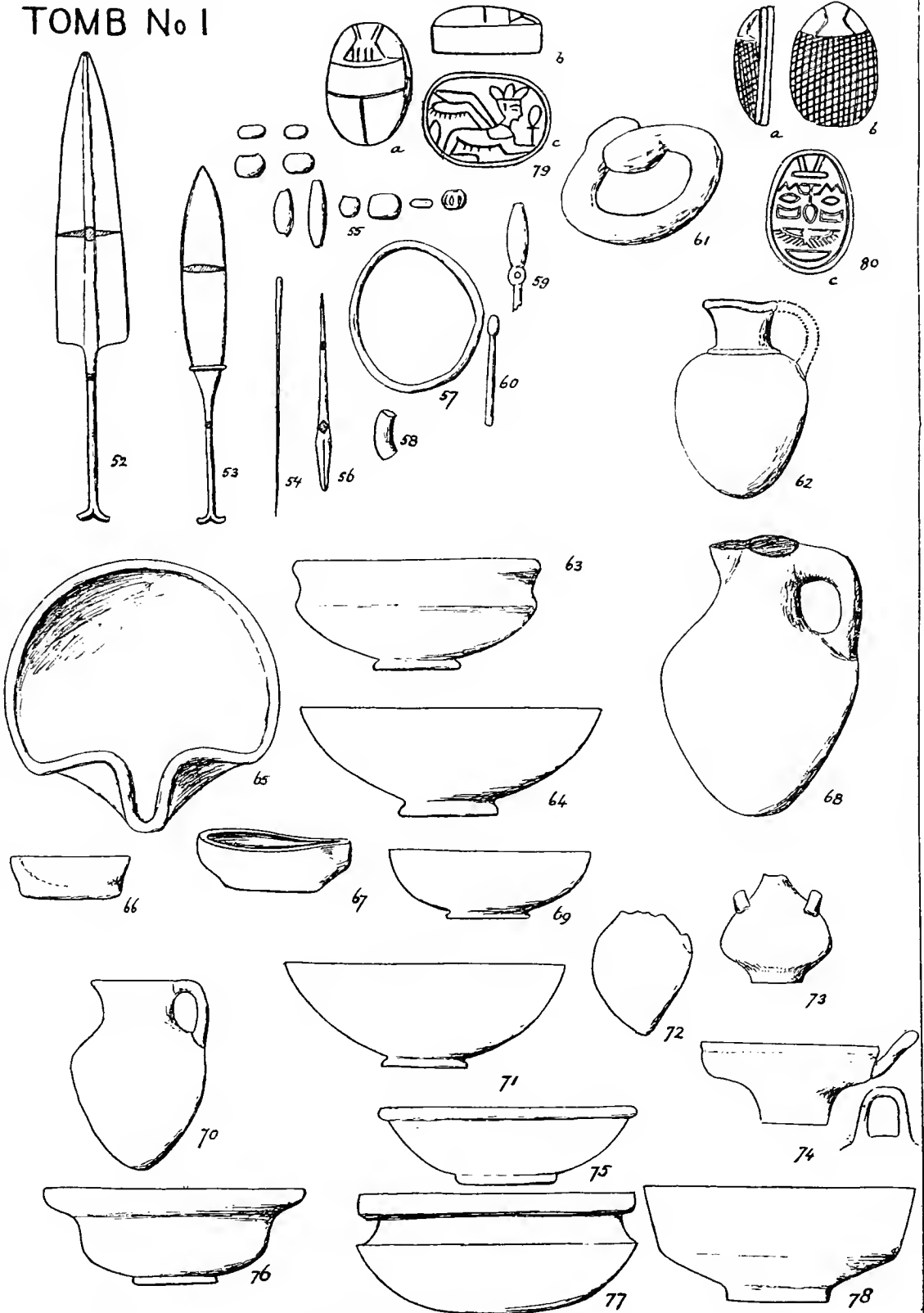

4 in 0 1 2 3 4 fig 79 to four times scale; fig 60 do. less 0 5 10 15  
 fig 57 to double scale  
 figs. 70, 71, 72, 73 to half scale

TOMB No 7

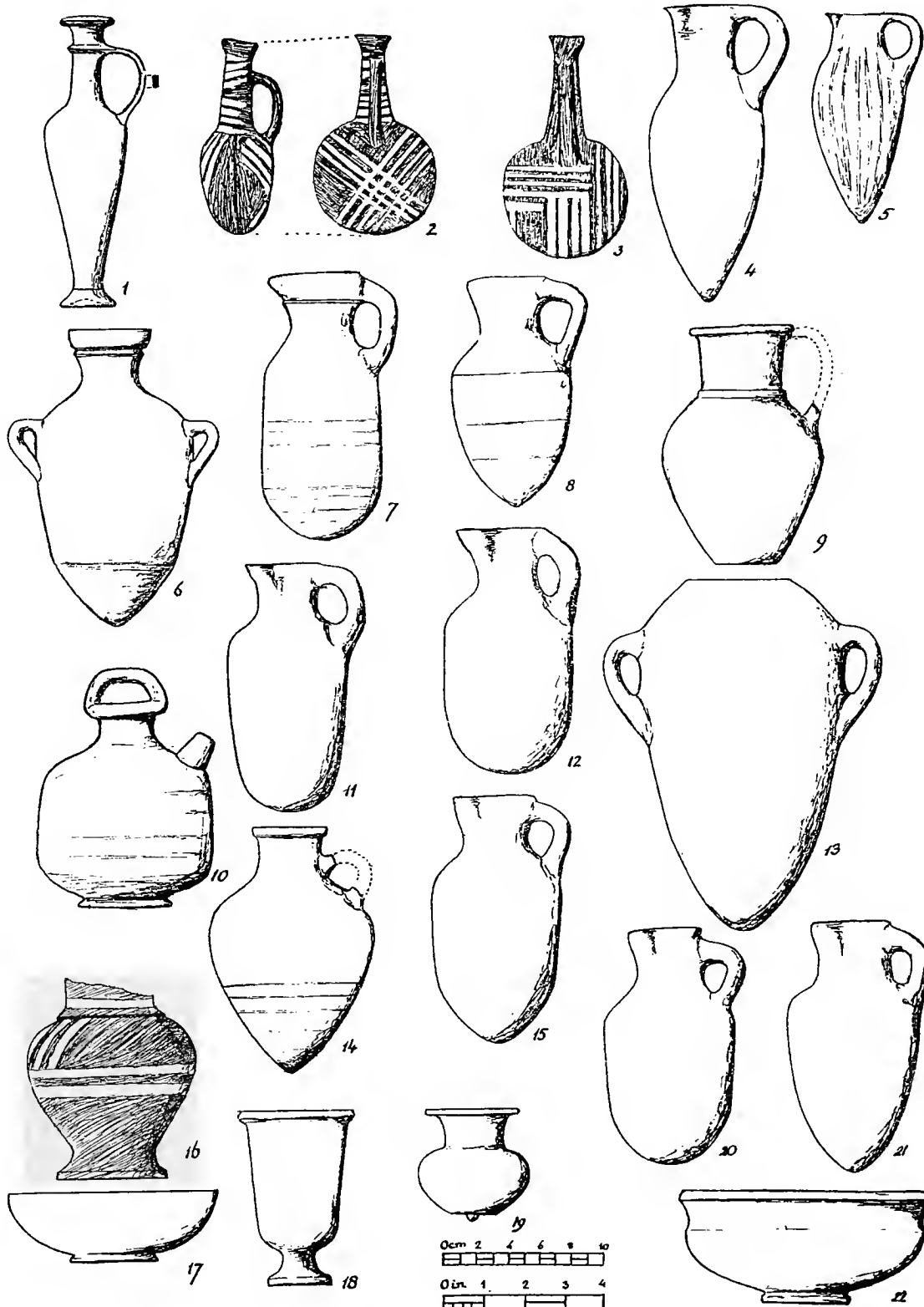





TOMB No 7

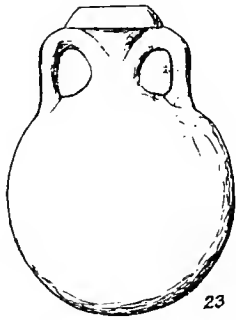

23



25



26



27



24

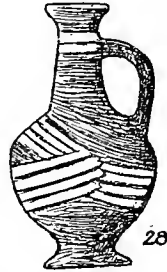

28



29

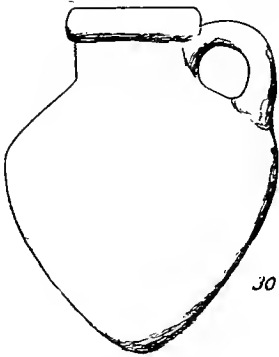

30



31

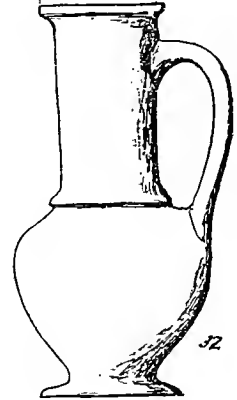

32



34

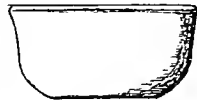

35



37

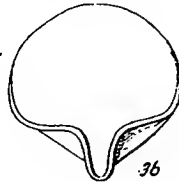

36



38

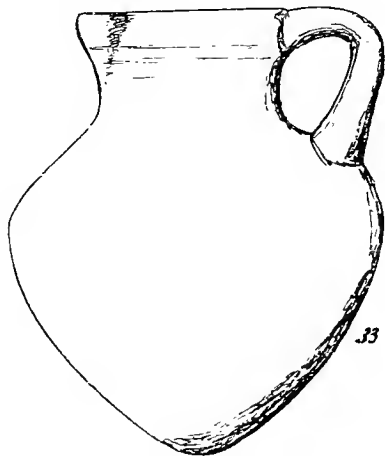

33



39

0cm	2	4	6	8	10
0cm	1	2	3	4	

TOMB No 7

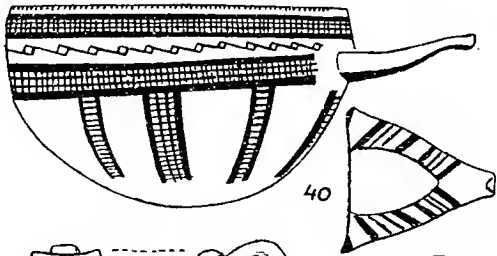

40

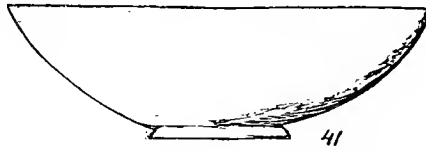

41

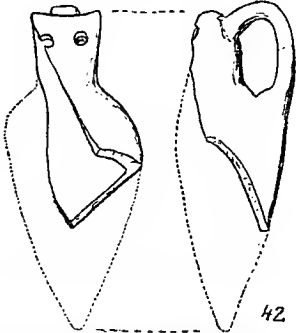

42

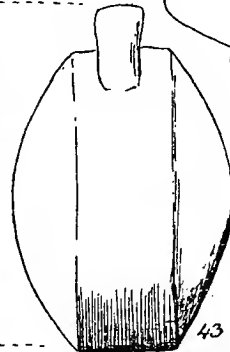
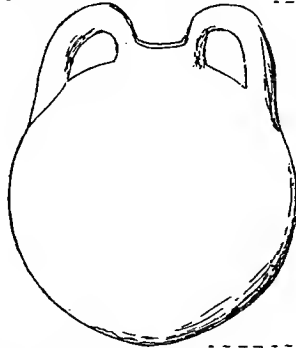

47



44



45

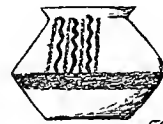

50

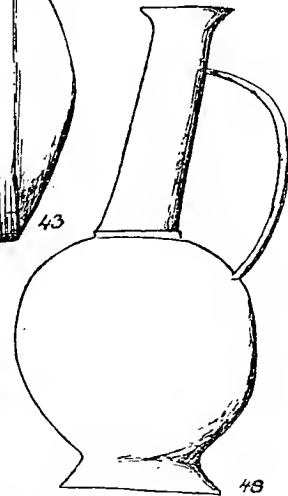

48

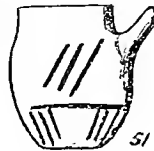

51



52

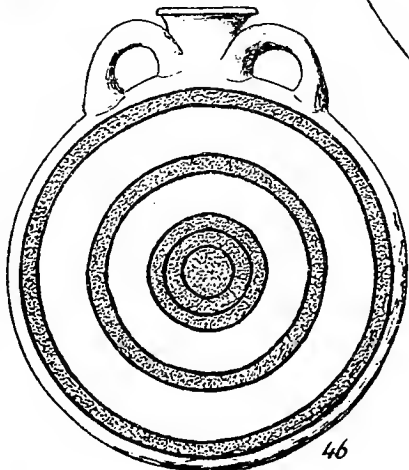

46

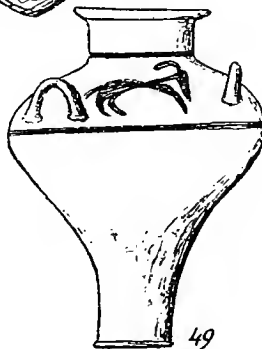

49

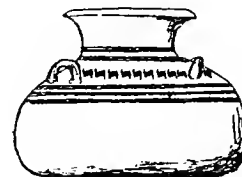

53

Ocm	2	4	6	8	10
Ocm	1	2	3	4	







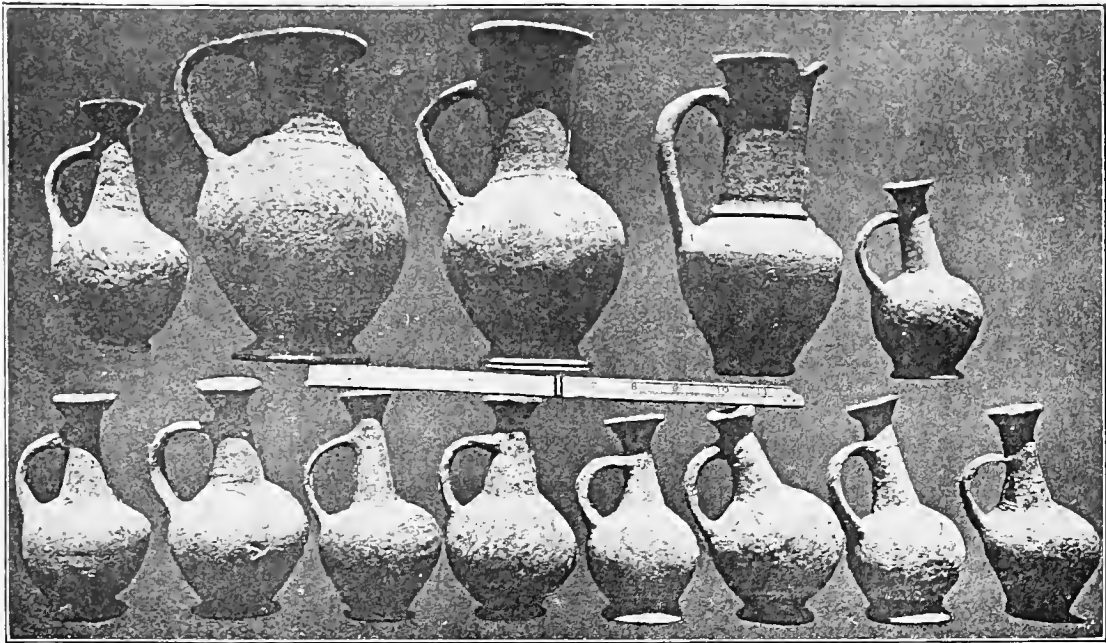

FIG. 1

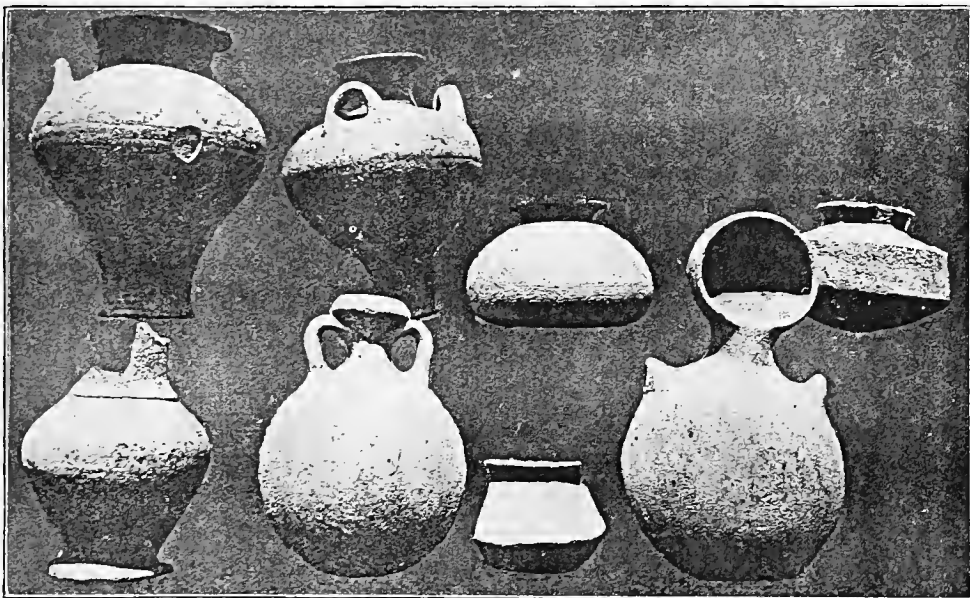

FIG. 2



FIG. 3

Plate Ixviii

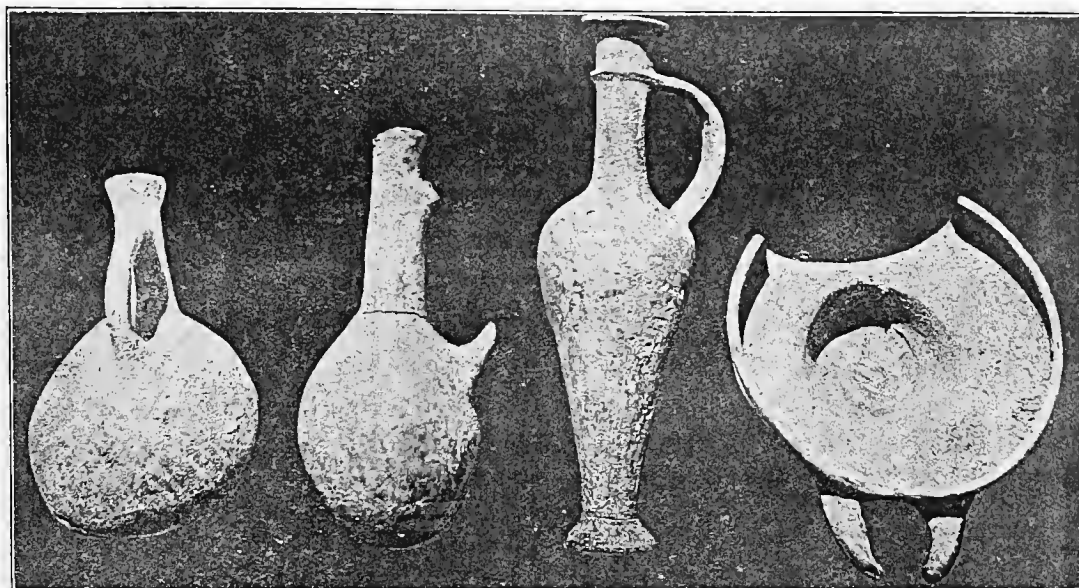

FIG. 1

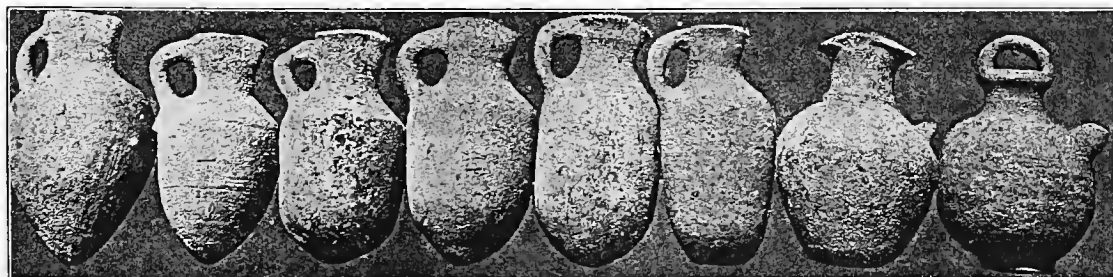

FIG. 2



FIG. 3

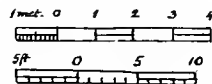
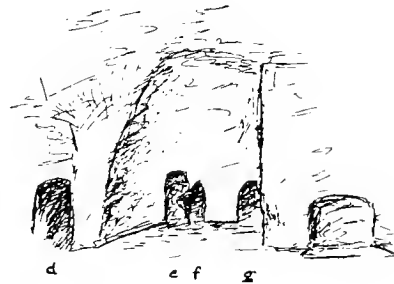
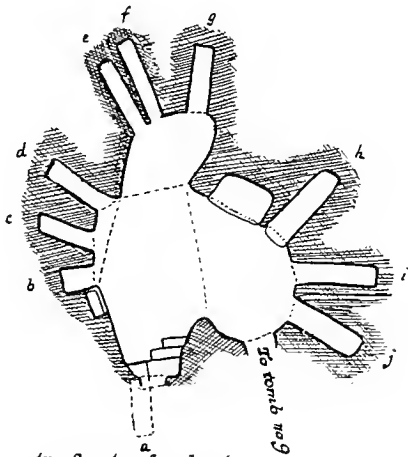
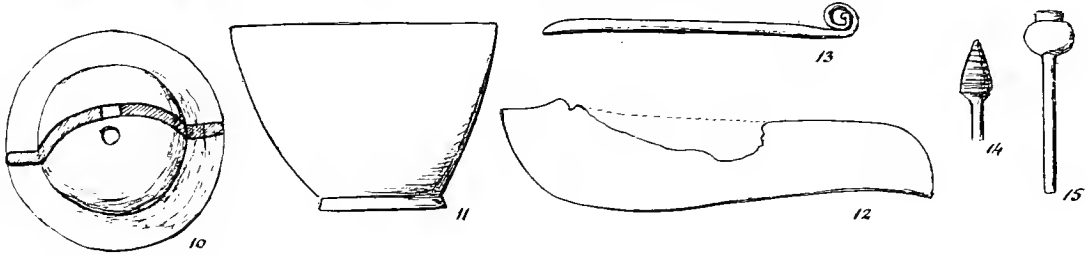
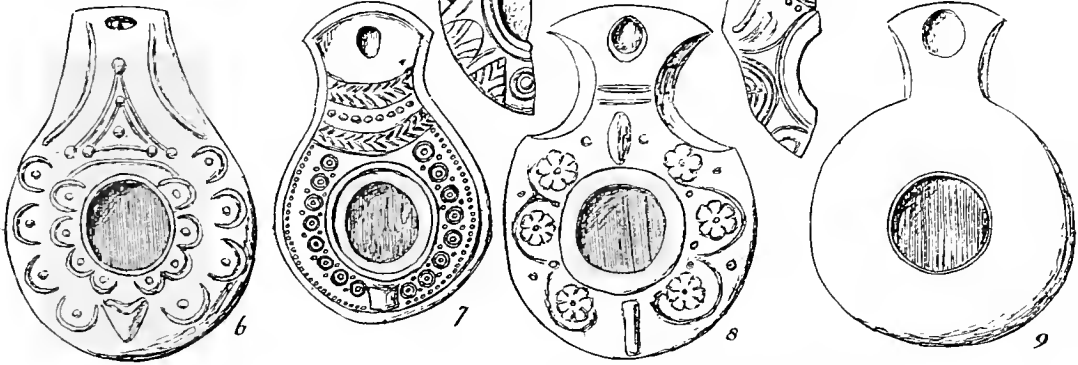
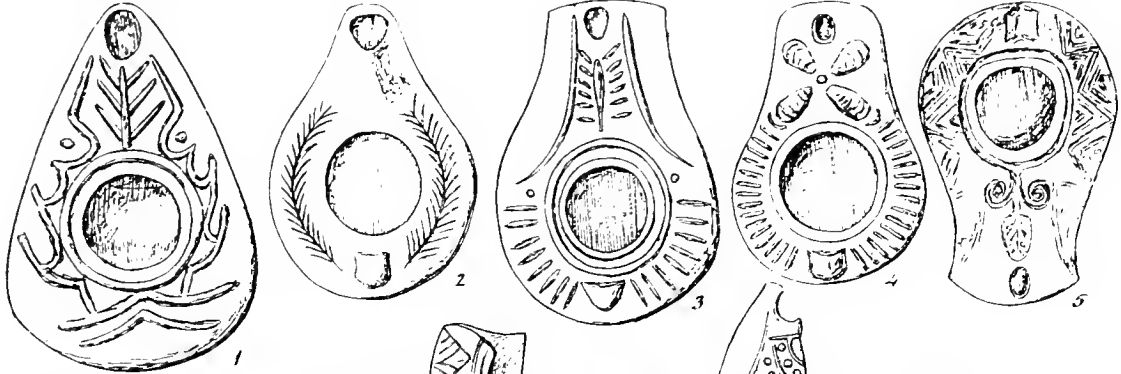

FIG. 4





TOMB No 8



TOMB No 9

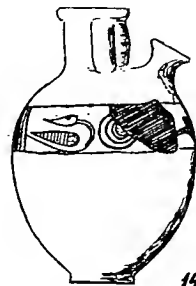
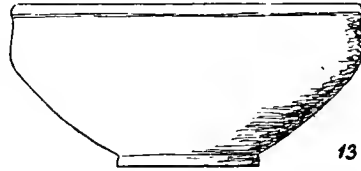
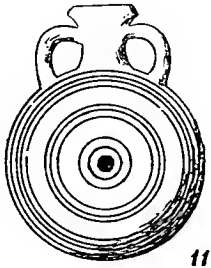
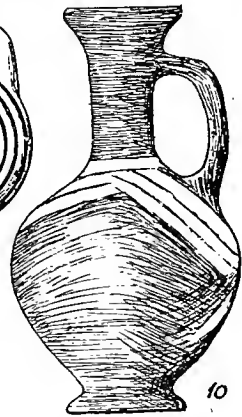
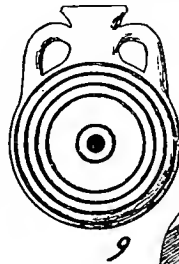
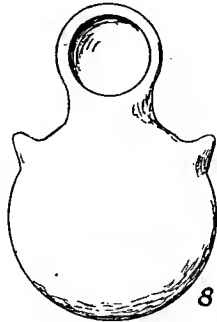
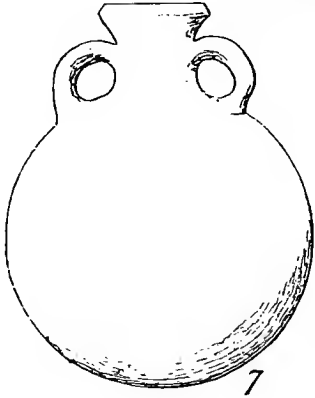
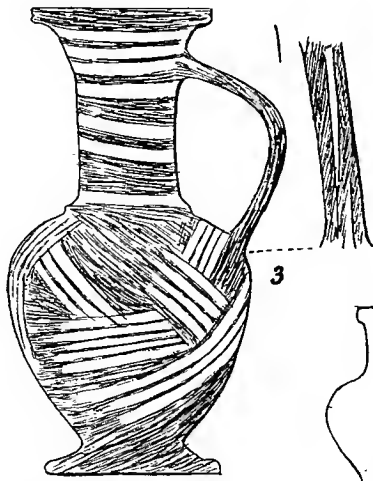
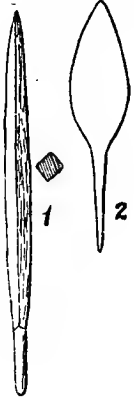

for scales see next plate







TOMB No 9

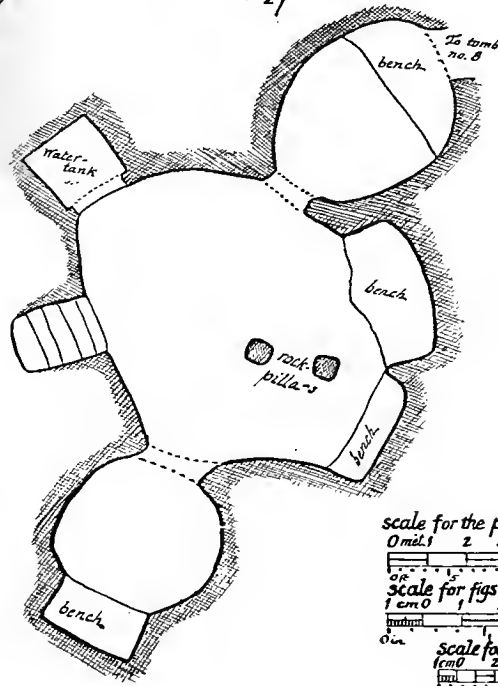
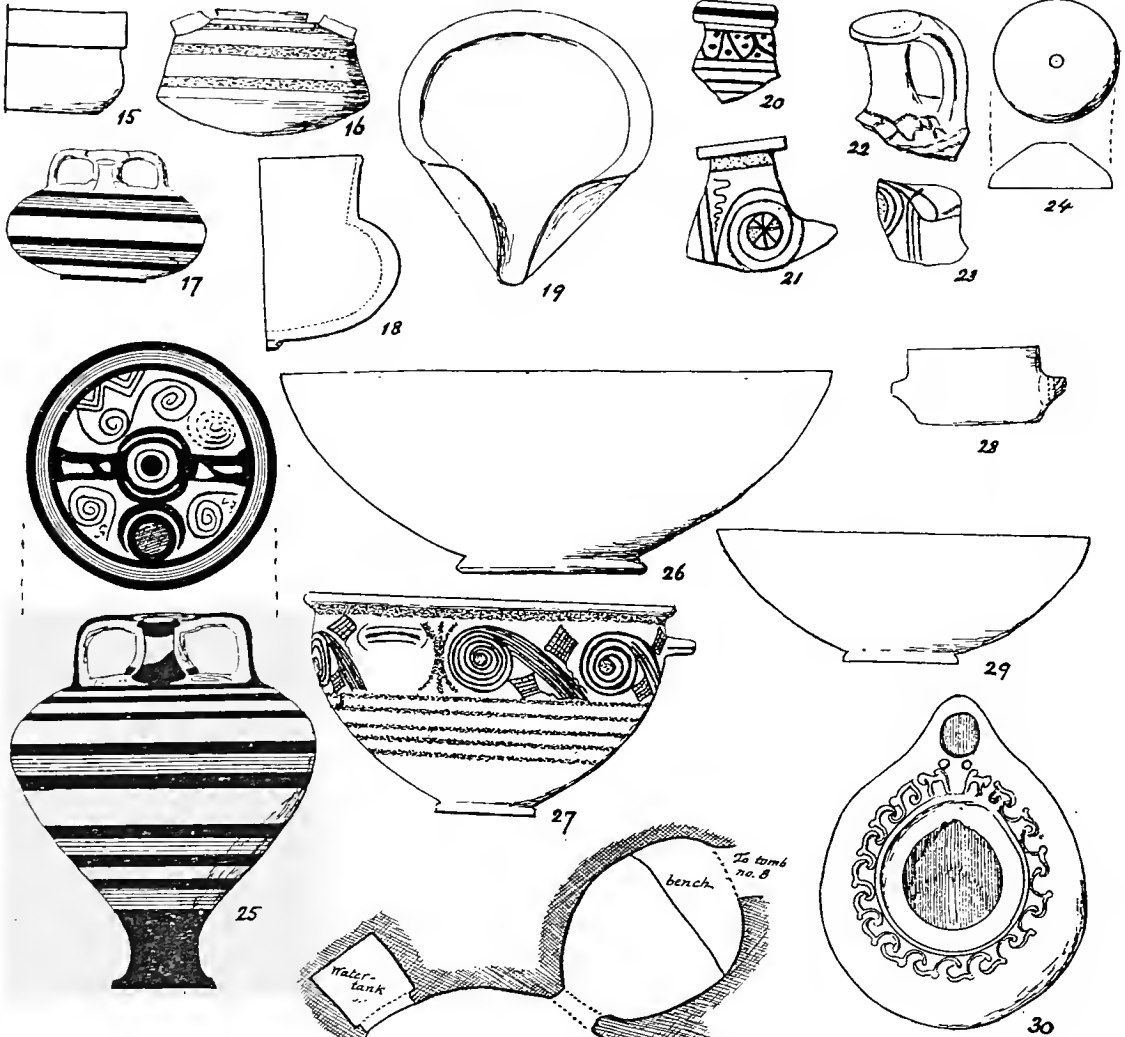

scale for the plan  
 0 m. 1 2 3 4 5 6 7 8 9 10  
 0 m. 1 2 3 4 5 6 7 8 9 10  
 scale for figs. 1, 2, 16, 18, 24, 30  
 1 cm 0 1 2 3 4 5 6 7 8 9  
 0 m. 1 2 3 4 5 6 7 8 9 10  
 scale for figs. 3-15, 17, 19-23, 25-29  
 1 cm 0 1 2 3 4  
 0 m. 1 2 3 4

TOMB DEPOSITS

No. 18

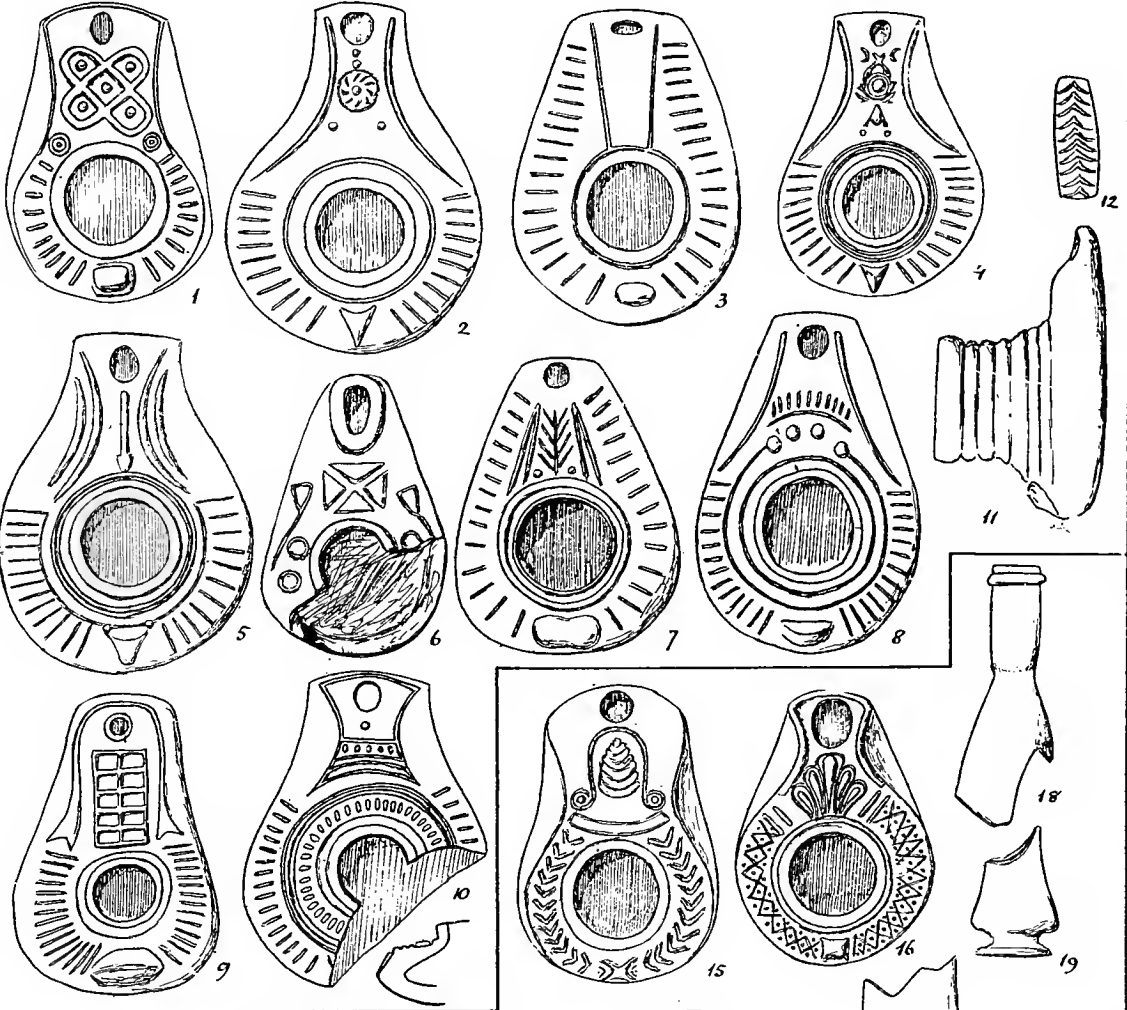

No. 23

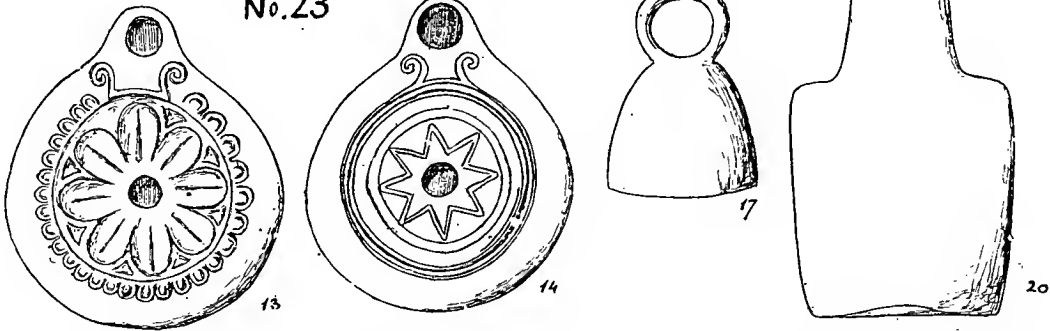

No. 21

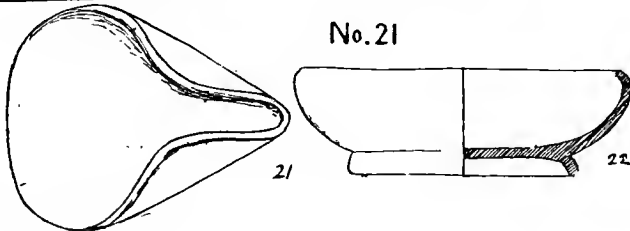

No. 77



0cm 1 2 3 4 5  
 0in 1 2  
 figs 21, 22  
 to half scale





TOMB No. 28

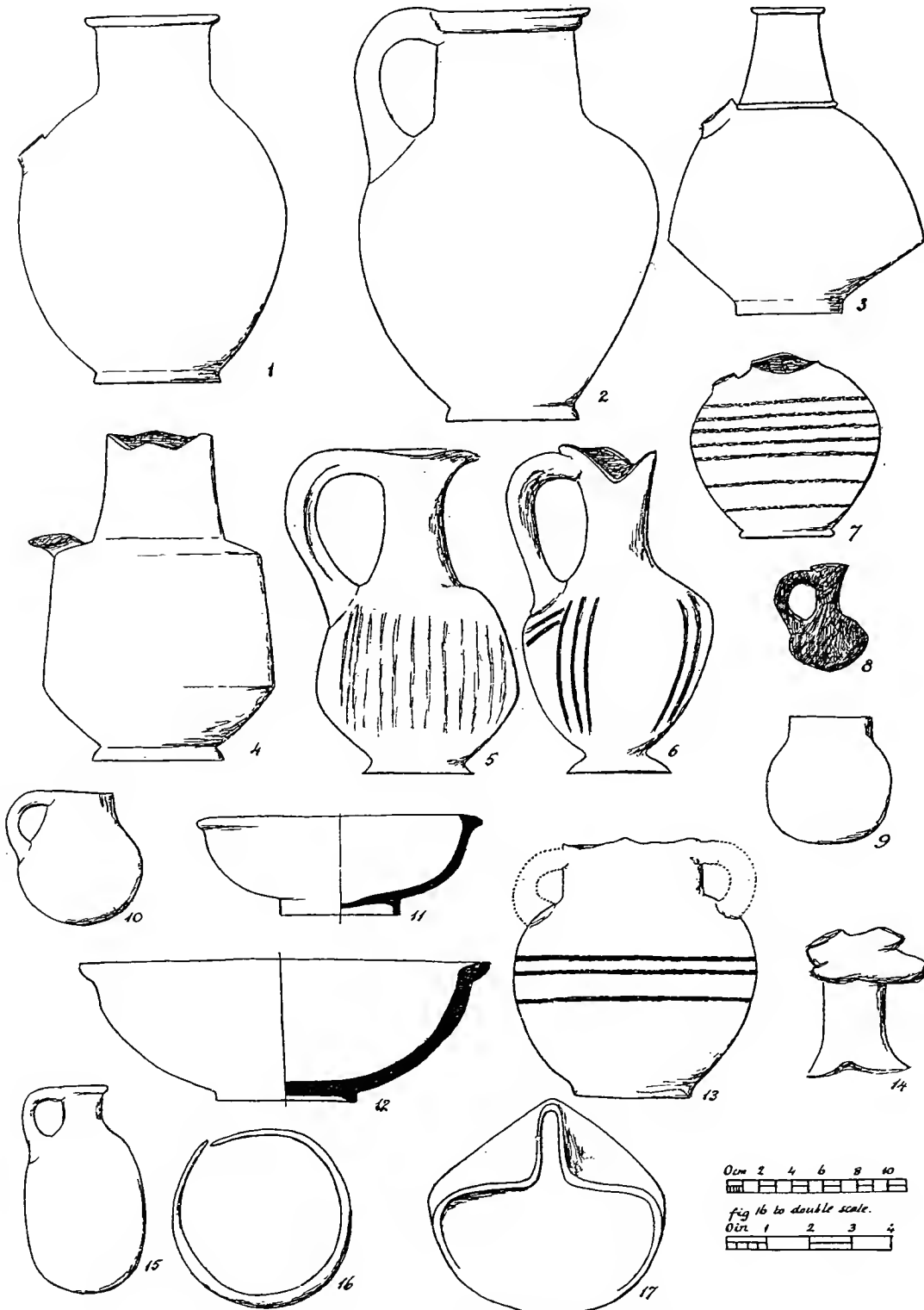

0cm 2 4 6 8 10  
fig 16 to double scale.  
0cm 1 2 3 4

TOMB No. 30

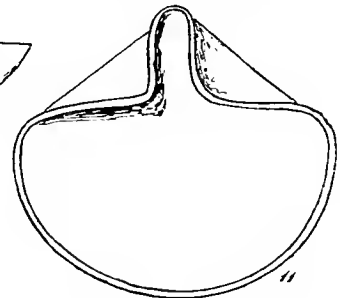
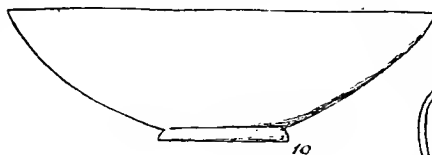
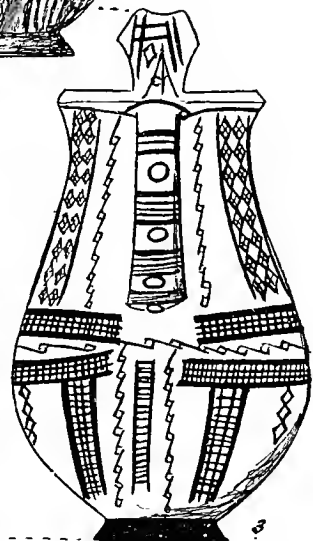
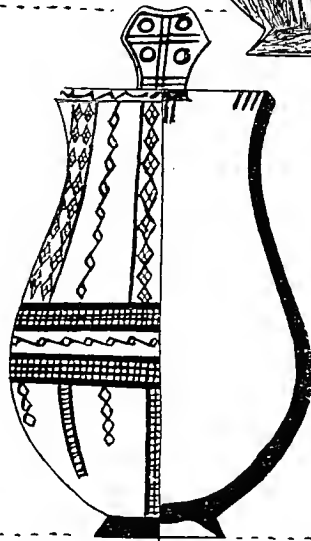
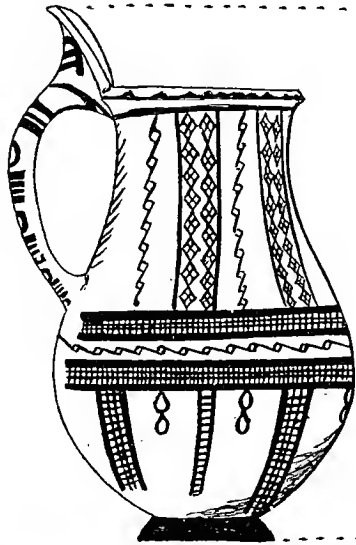
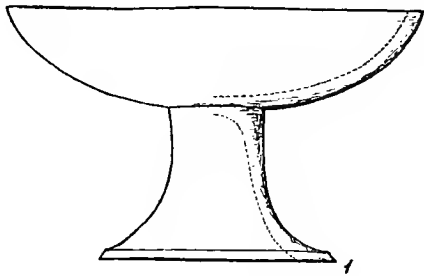







TOMB No. 30

cm 0 1 2 3 4

cm 0 1 2 3 4 5

in. 0 1

in. 0 1

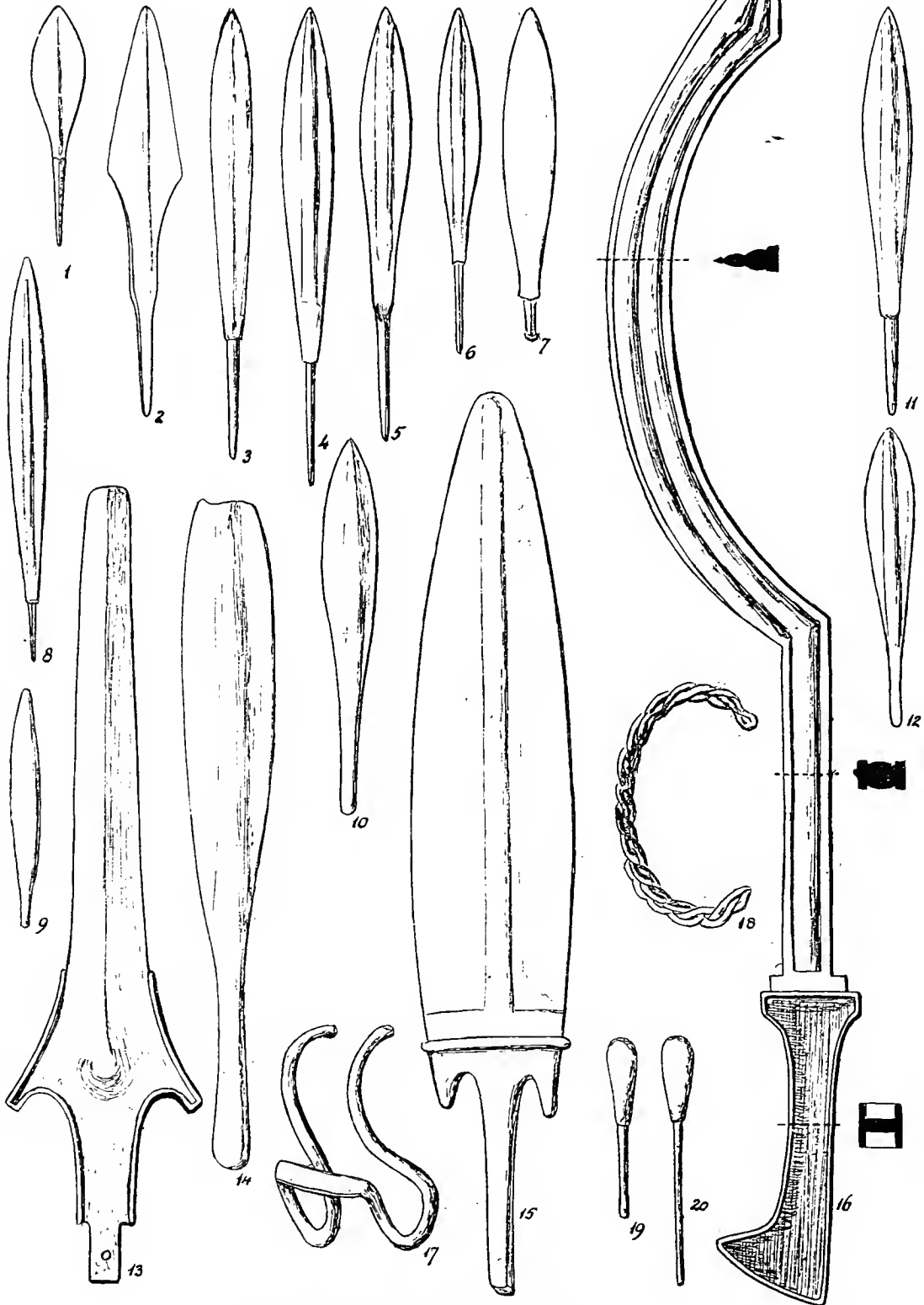

TOMB No 31

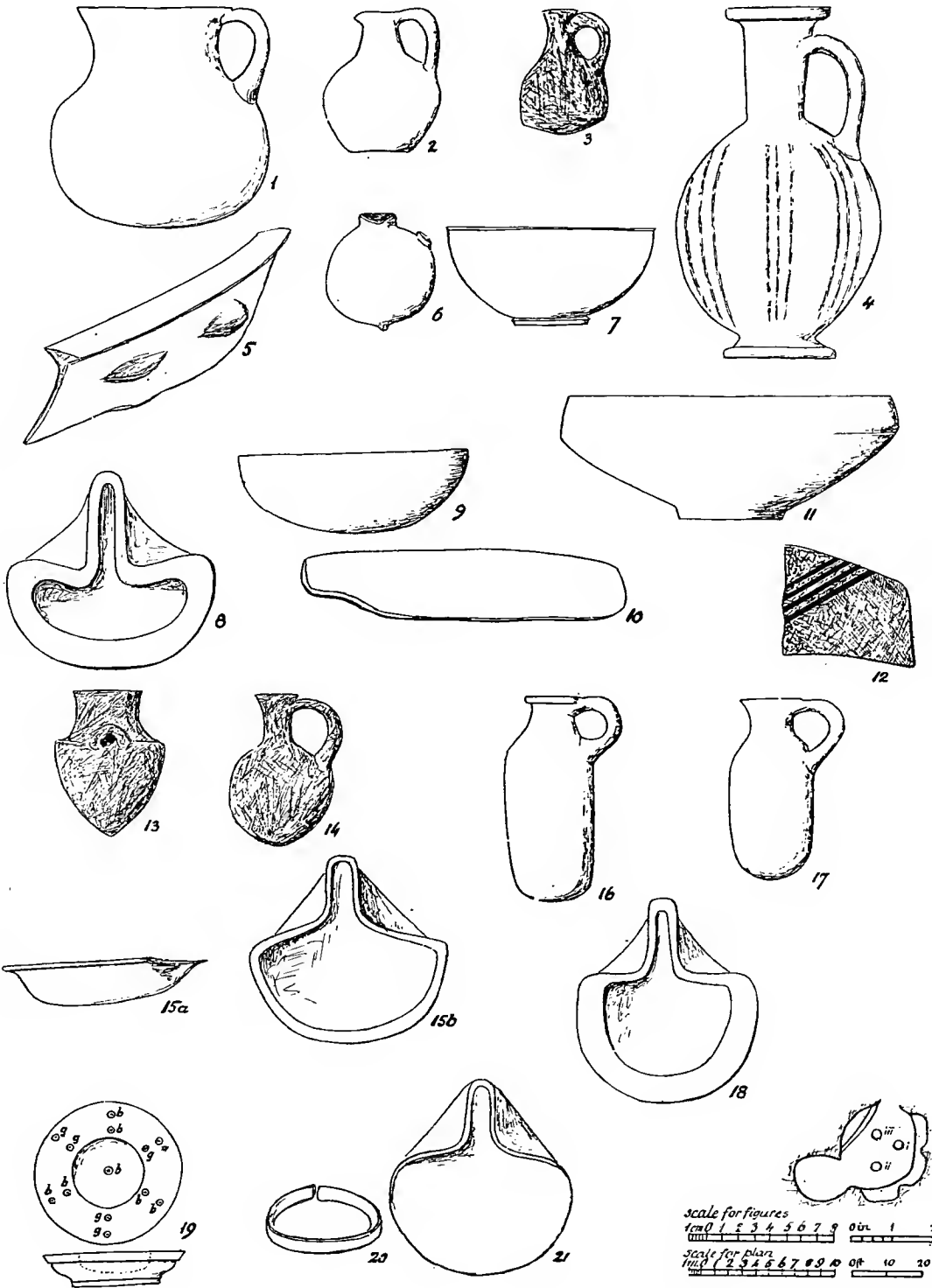

scale for figures  
cm 0 1 2 3 4 5 6 7 8 0 in. 1 2  
scale for plans  
cm 0 1 2 3 4 5 6 7 8 9 10 0 ft. 10 20





TOMB No 36

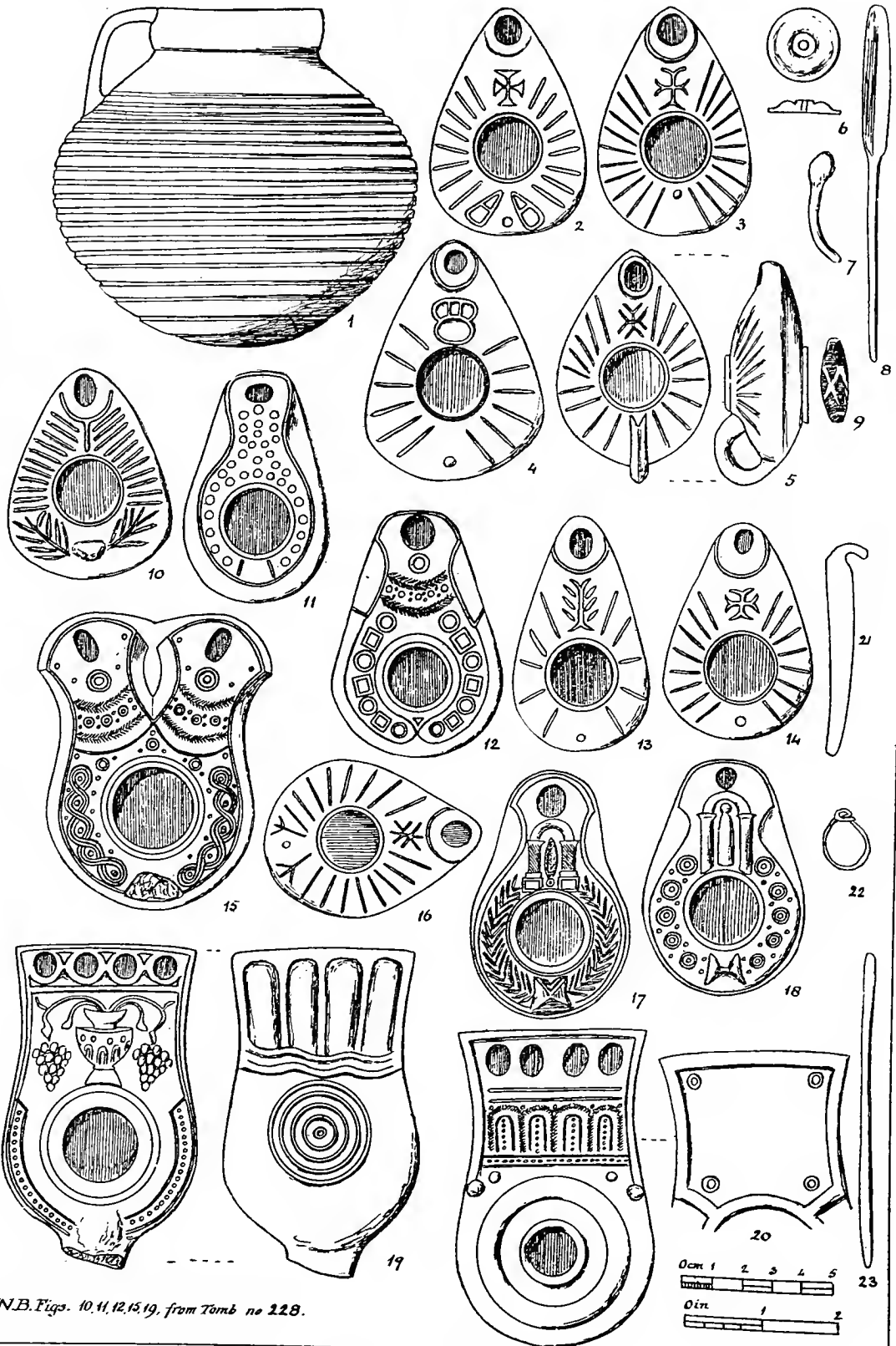

N.B. Figs. 10, 11, 12, 15, 19, from Tomb no 228.



TOMB DEPOSITS

0 in 1 2  
0 cm 1 2 3 4 5  
figs 50 & 51  
to half scale

No. 40

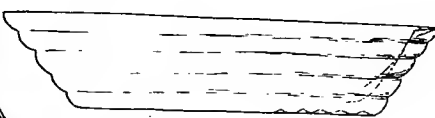
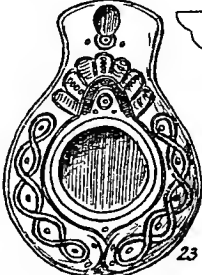
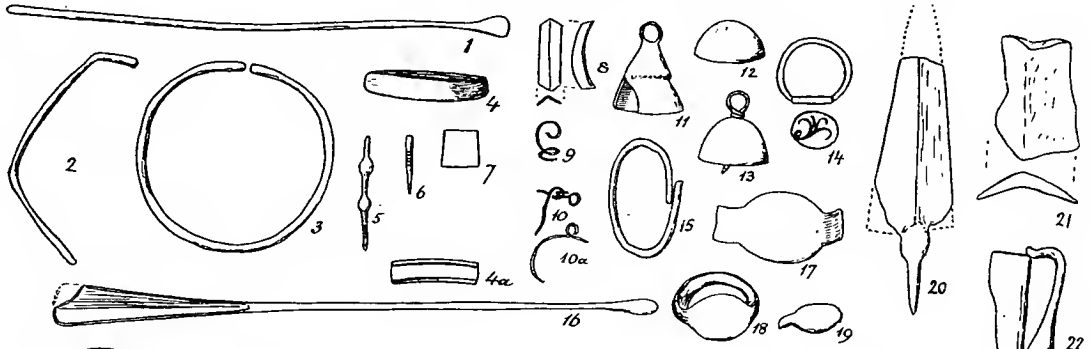

black paste, groove incised with lime  
green paste  
blue paste  
green, yellow-green  
black paste  
blue, green spot in middle surrounded by brown  
black, 3 vermilion C's with brown rays  
carnelian  
amethyst  
yellow glass  
green glass  
white glass  
blue glass  
brown glass  
brown glass, white lines  
black glass, yellow lines  
do. yellow lines  
black glass, white line  
purple glass  
grey paste  
blackish blue glass  
green on brown  
yellow on brown  
amber  
brown paste

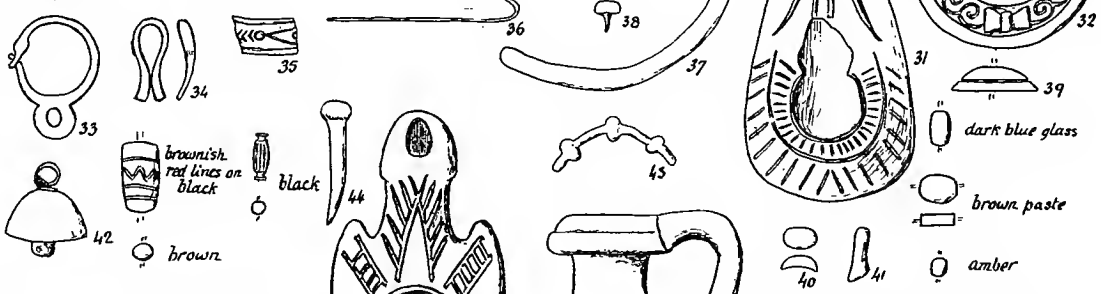

No. 122

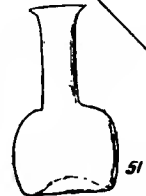

No. 104

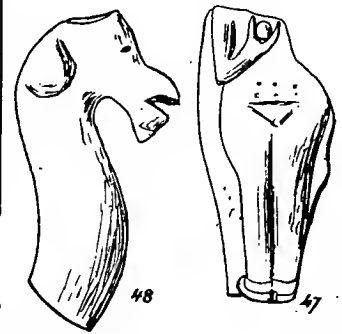







TOMB DEPOSITS

0 cm 1 2 3 4 5 (Figs 5-26 at half scale)

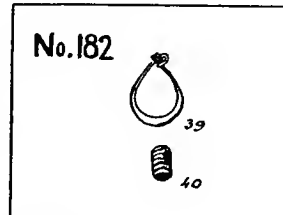
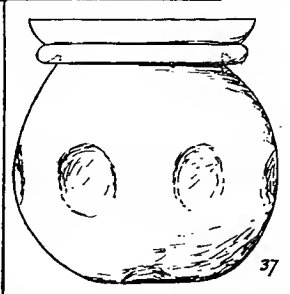
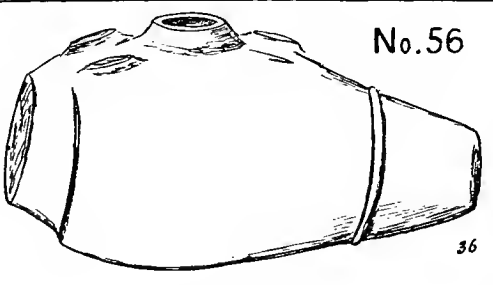
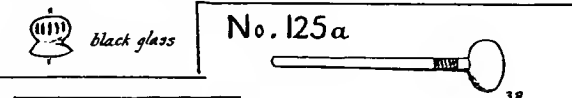
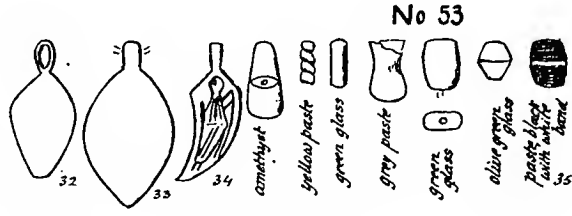
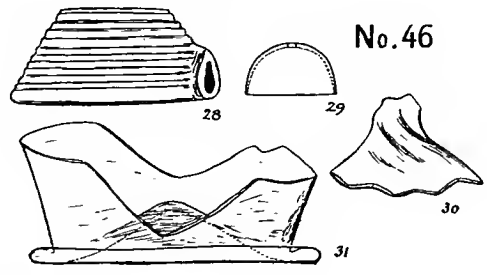
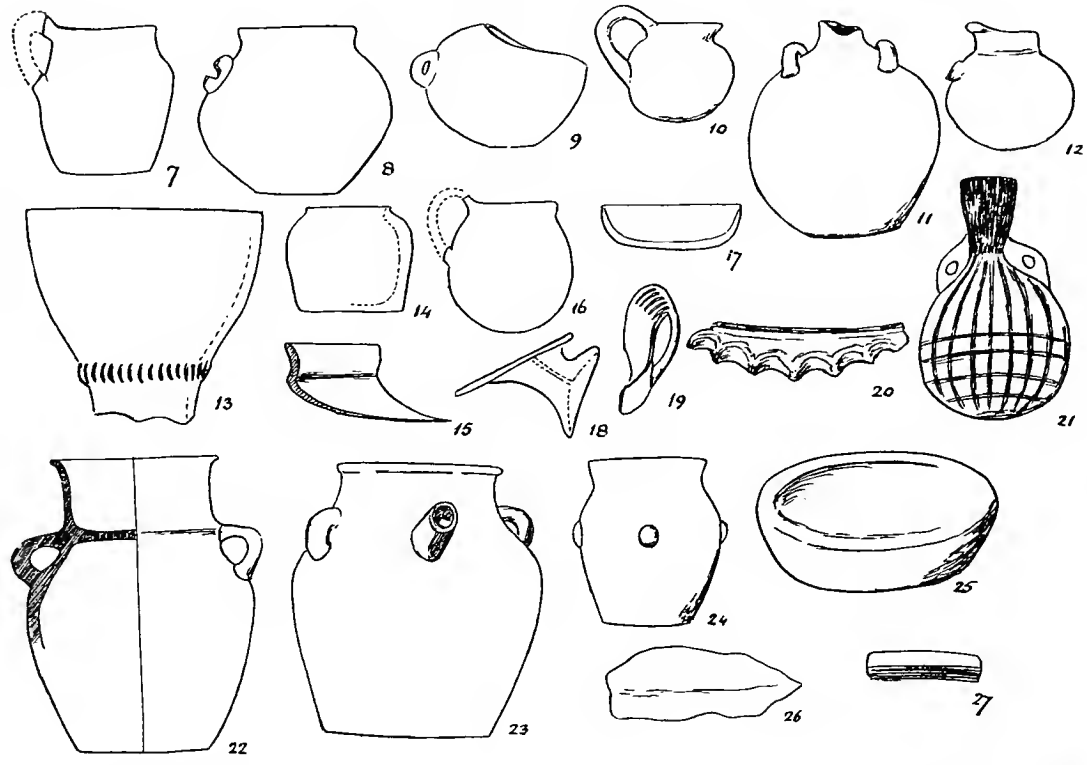
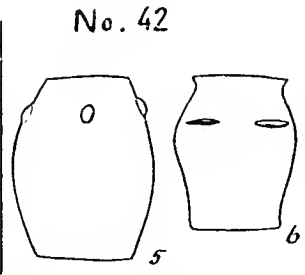
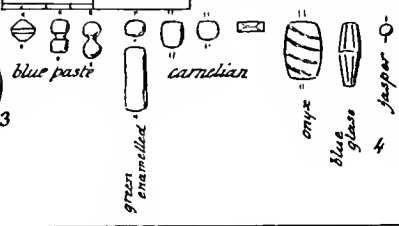
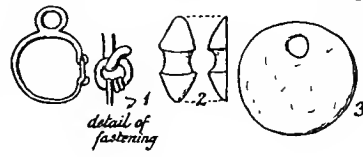

TOMB No. 56

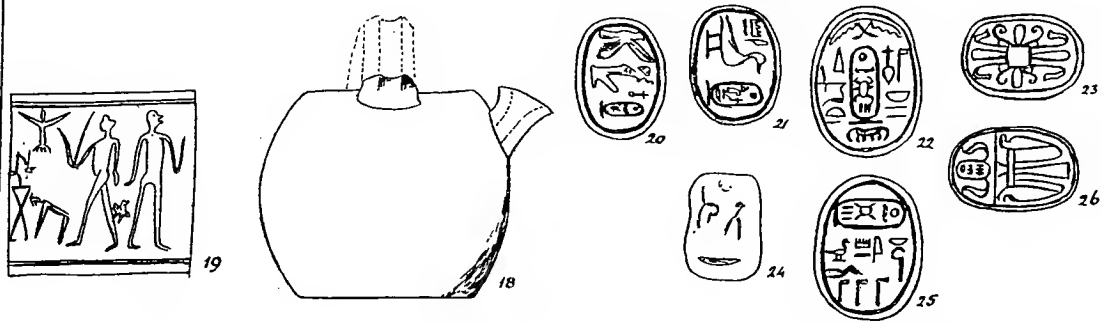
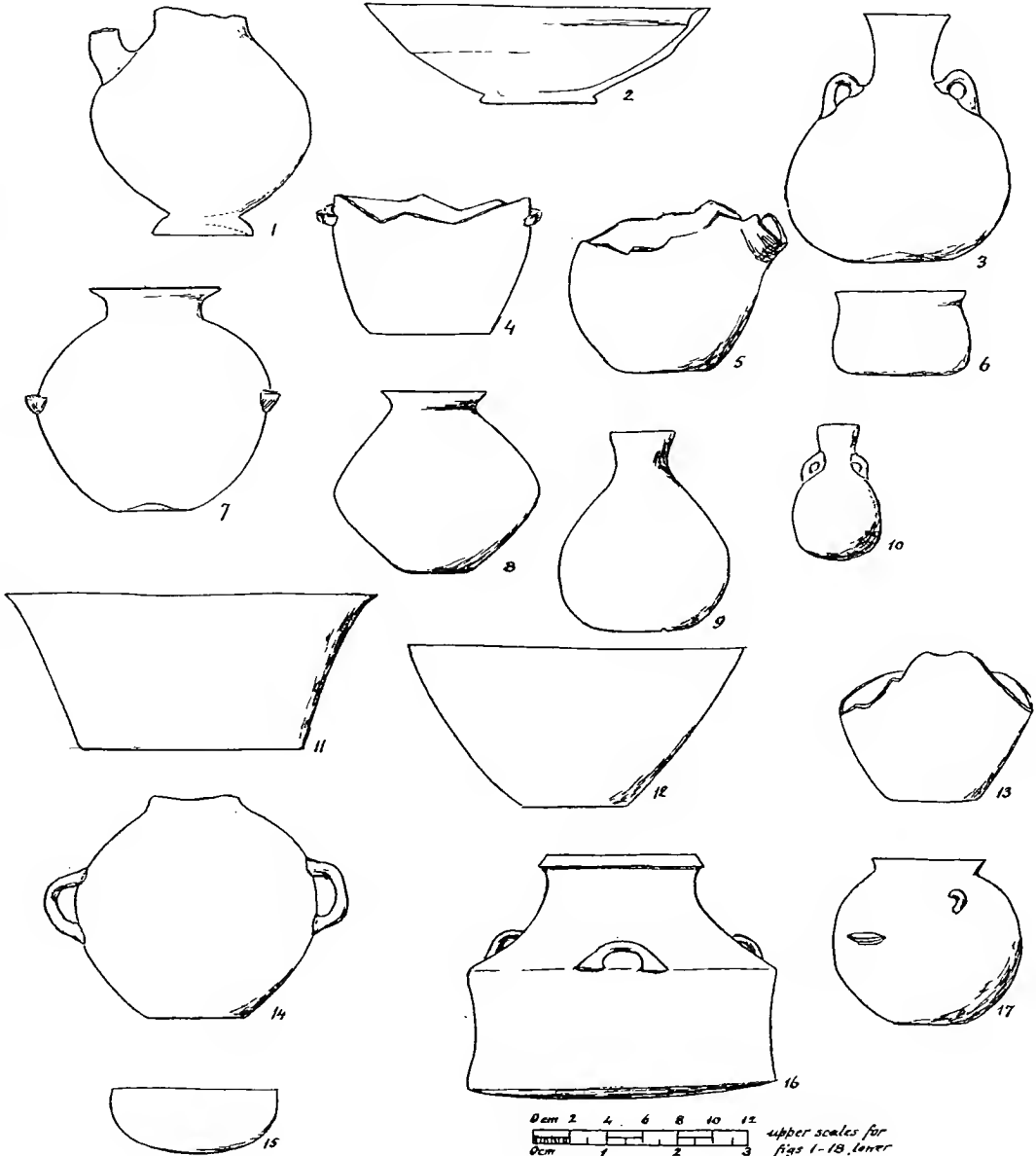





TOMB No. 58



TOMB No. 58

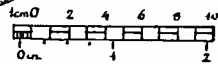
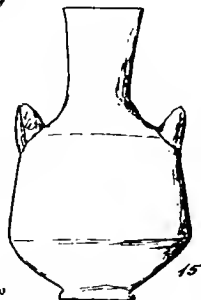
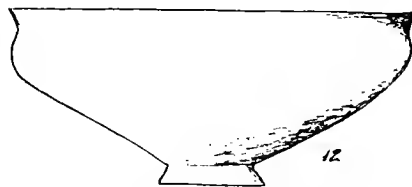
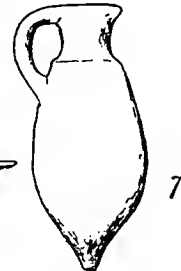
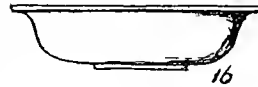
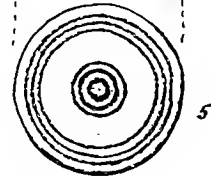
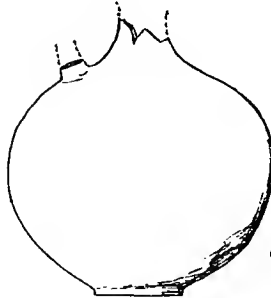
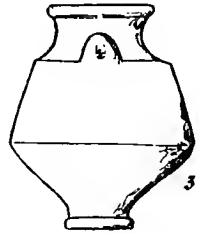
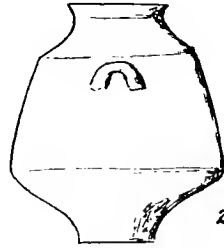
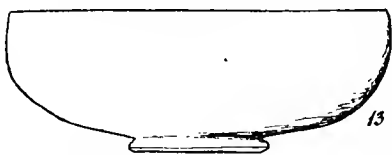
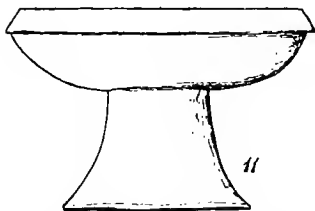
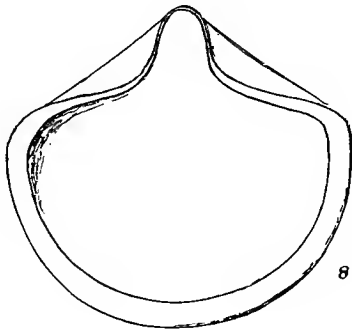
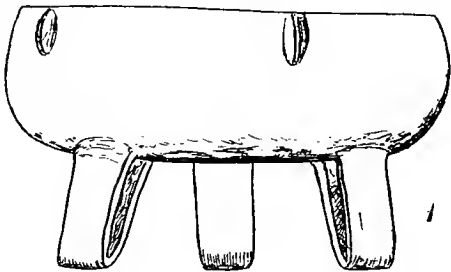
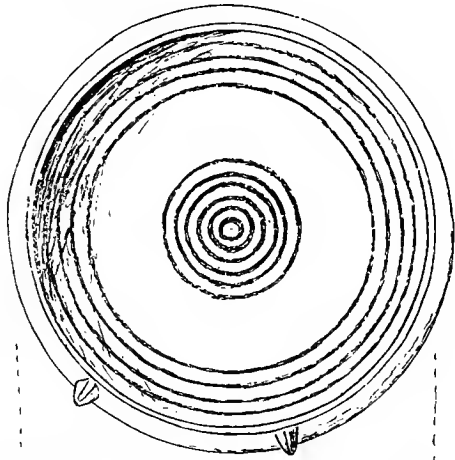







TOMB No. 58

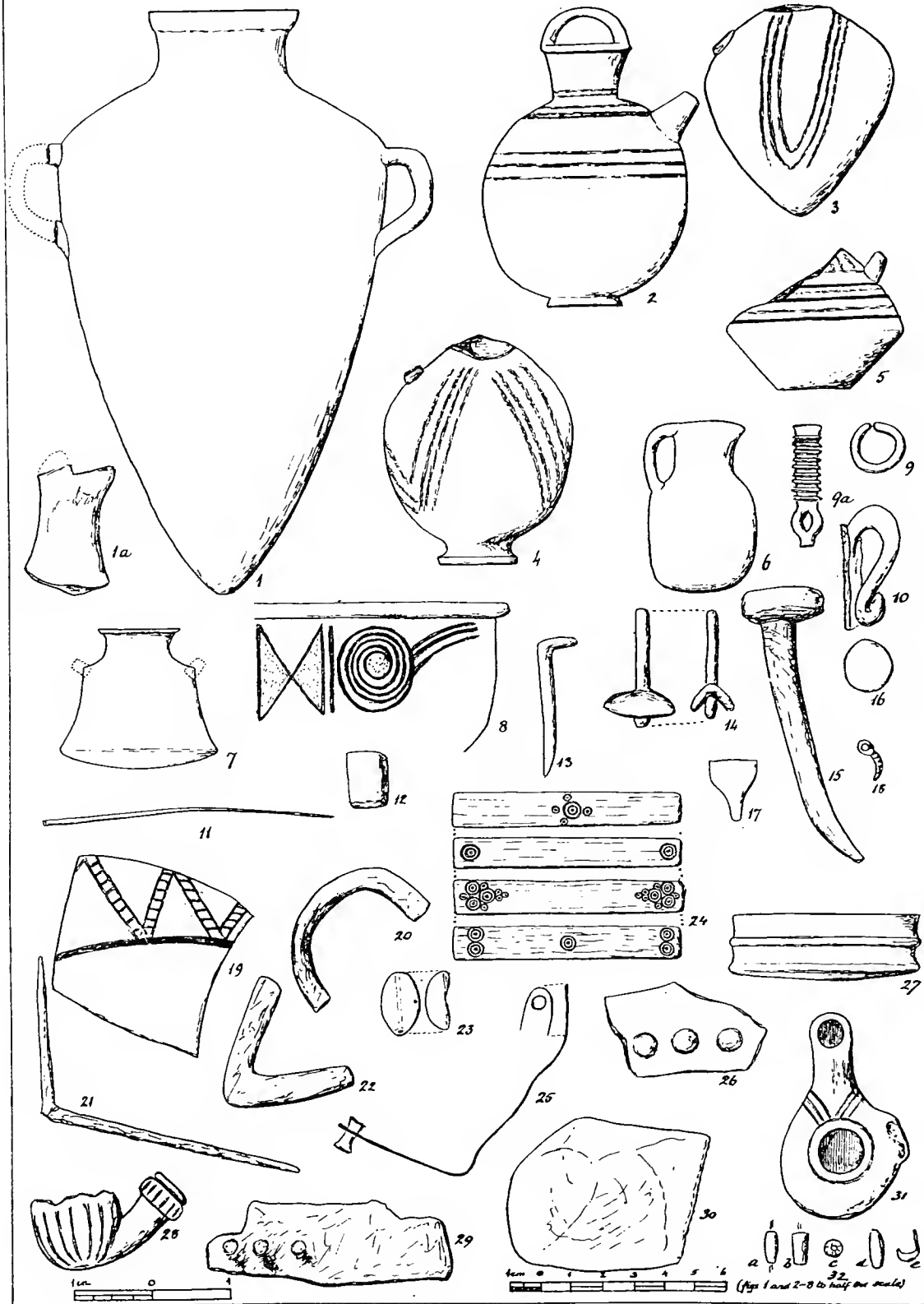

TOMB No 59

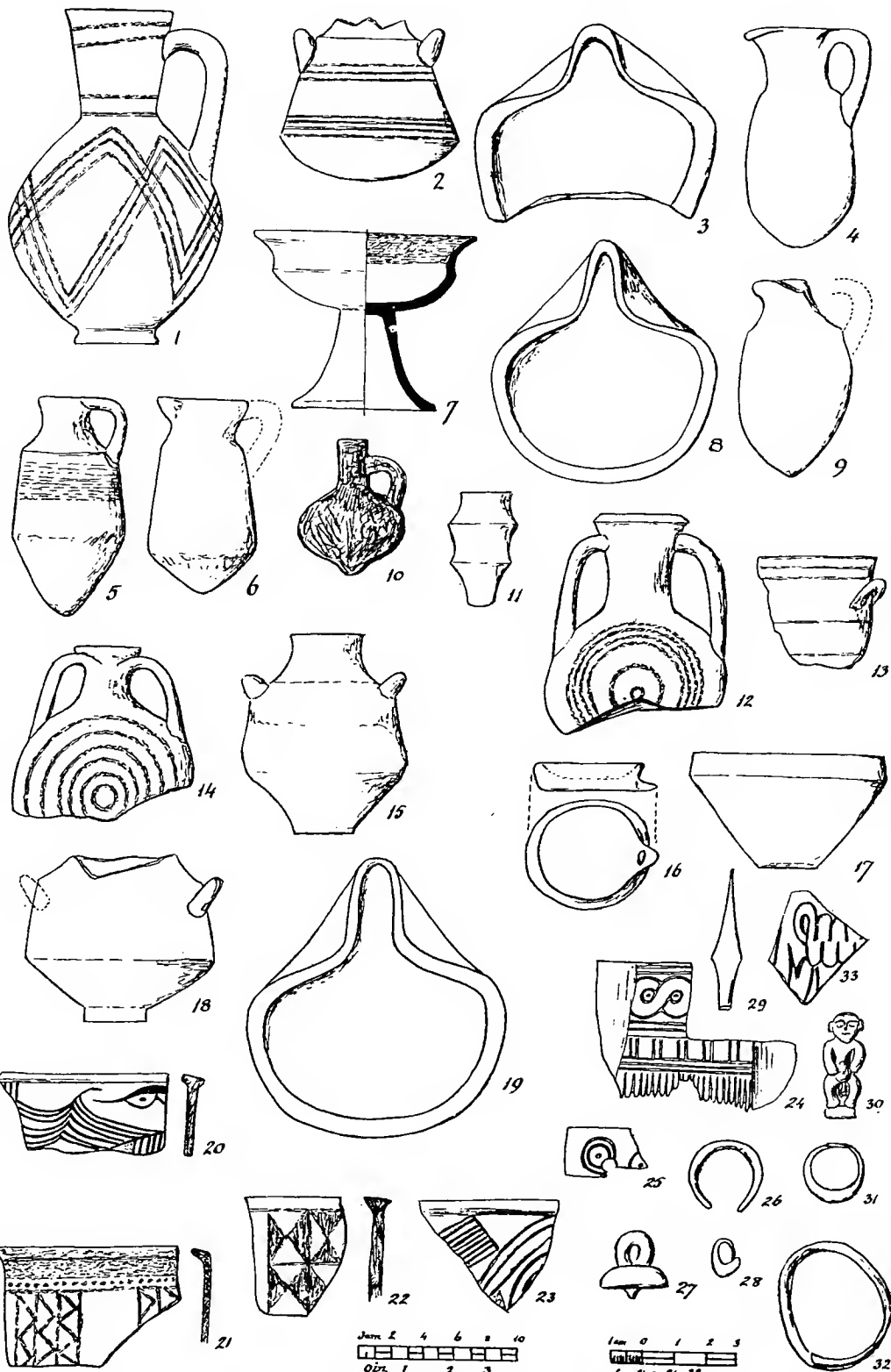

Scale bar for items 1-23:  
 0 2 4 6 8 10  
 0 2 4 6 8 10  
 1 2 3  
 1 inch

Scale bar for items 24-32:  
 1 2 3  
 for figs 24-32  
 1 inch





TOMB No 59

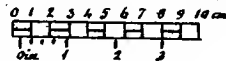
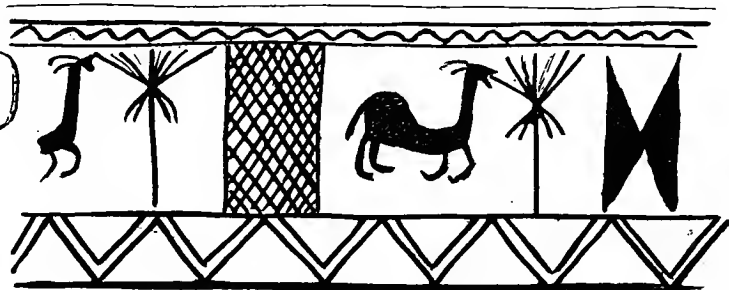
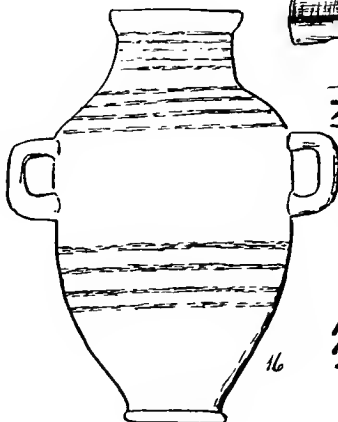
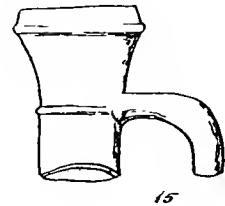
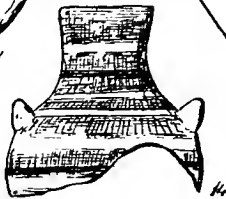
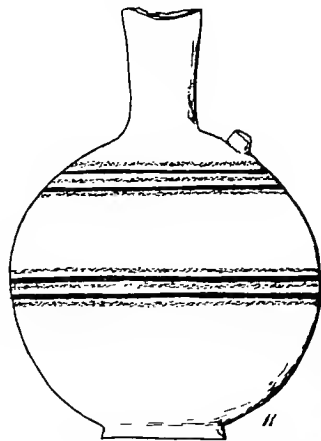
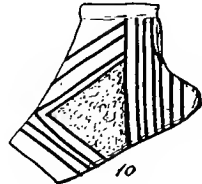
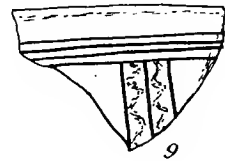
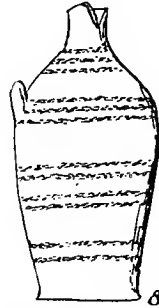
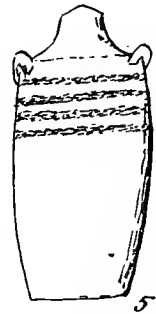
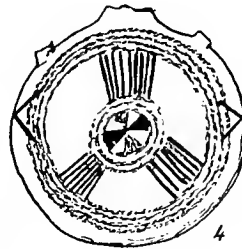
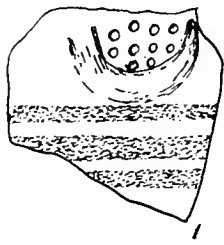

TOMBS No. 65-73

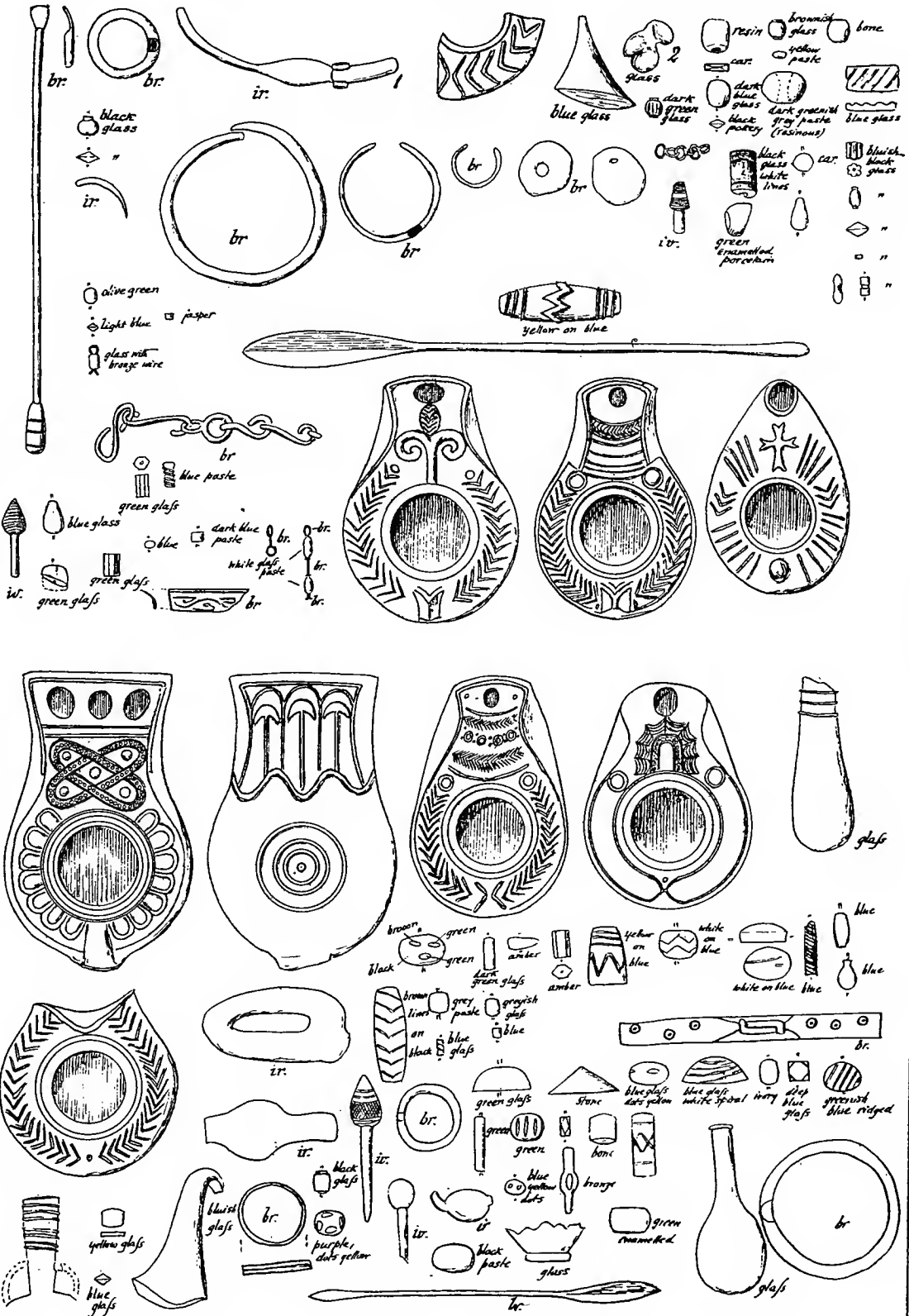







TOMBS No 84,85

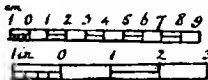
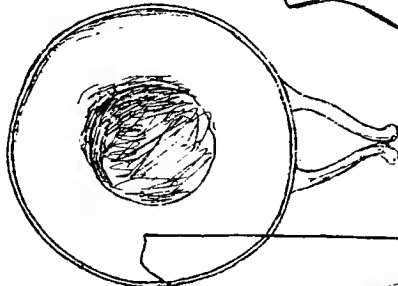
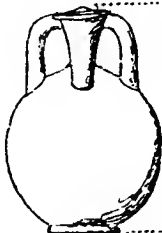
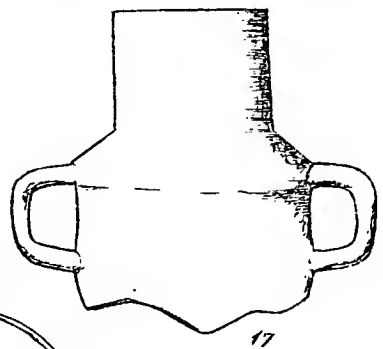
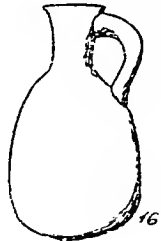
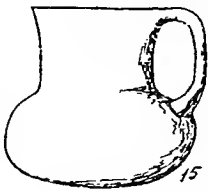
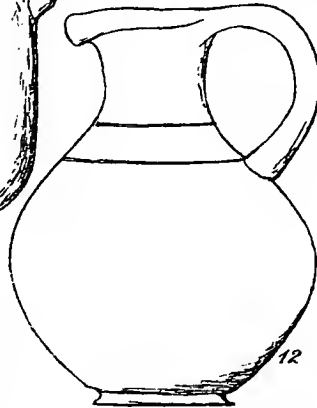
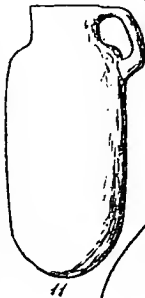
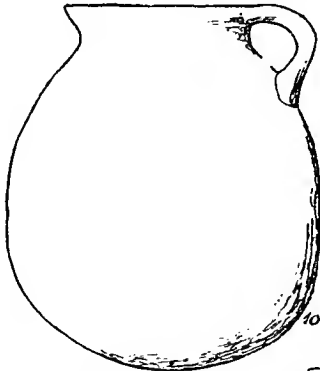
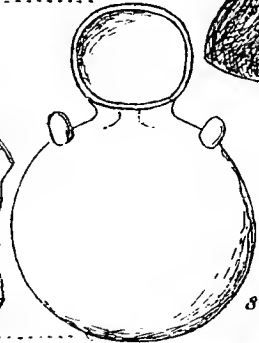
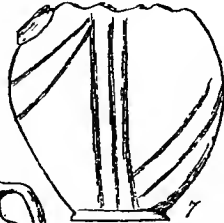
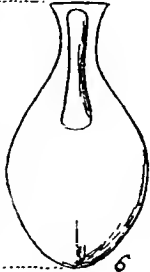
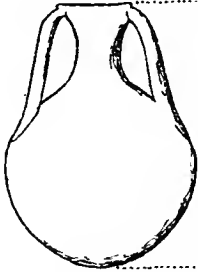
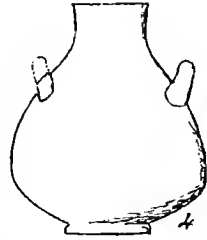
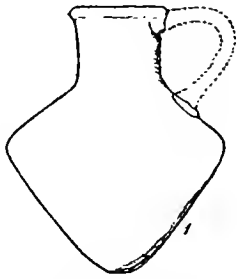

TOMBS No.84,85

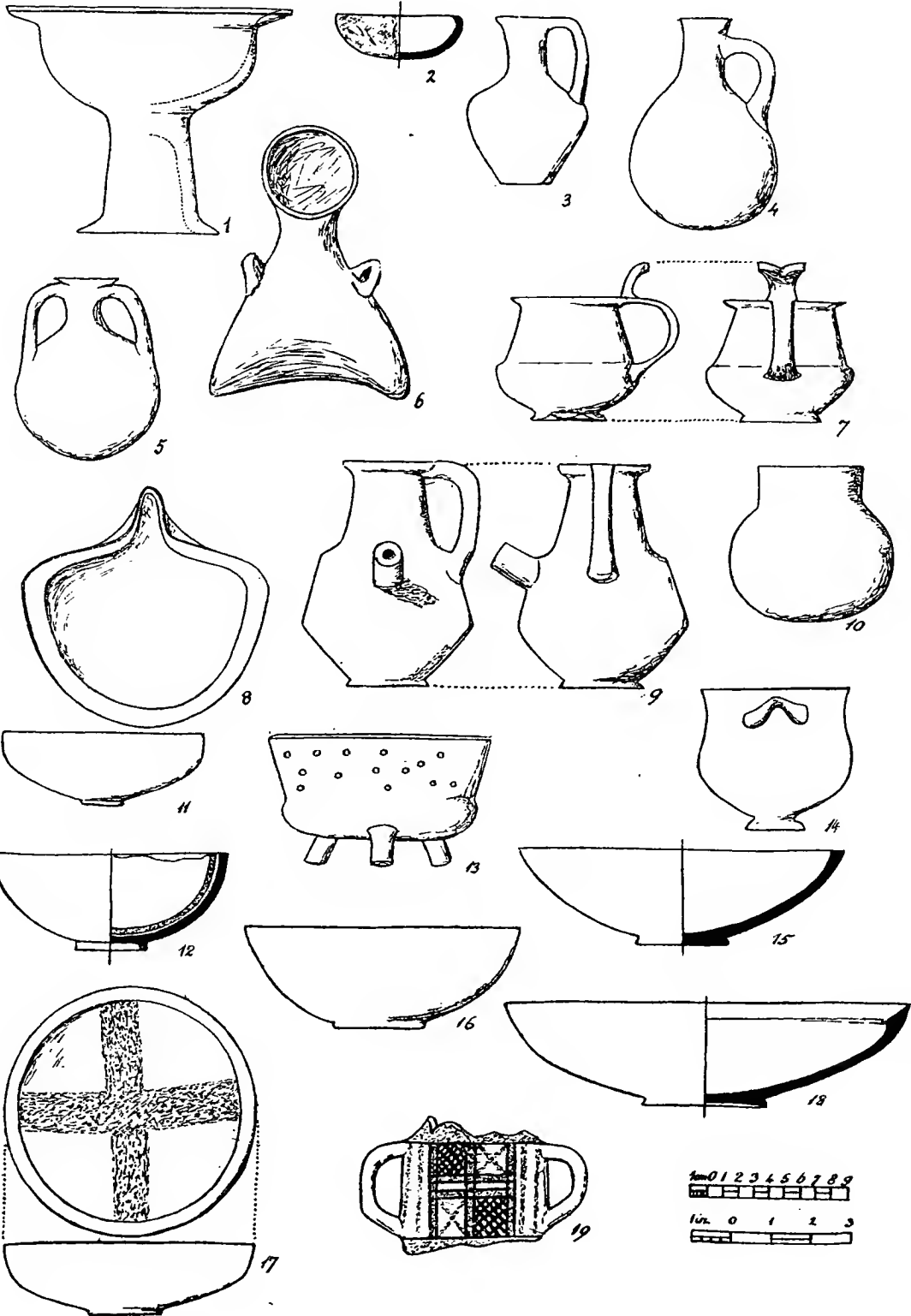

1cm 0 1 2 3  
0 1 2 3 4 5 6 7 8 9





TOMBS No 84,85

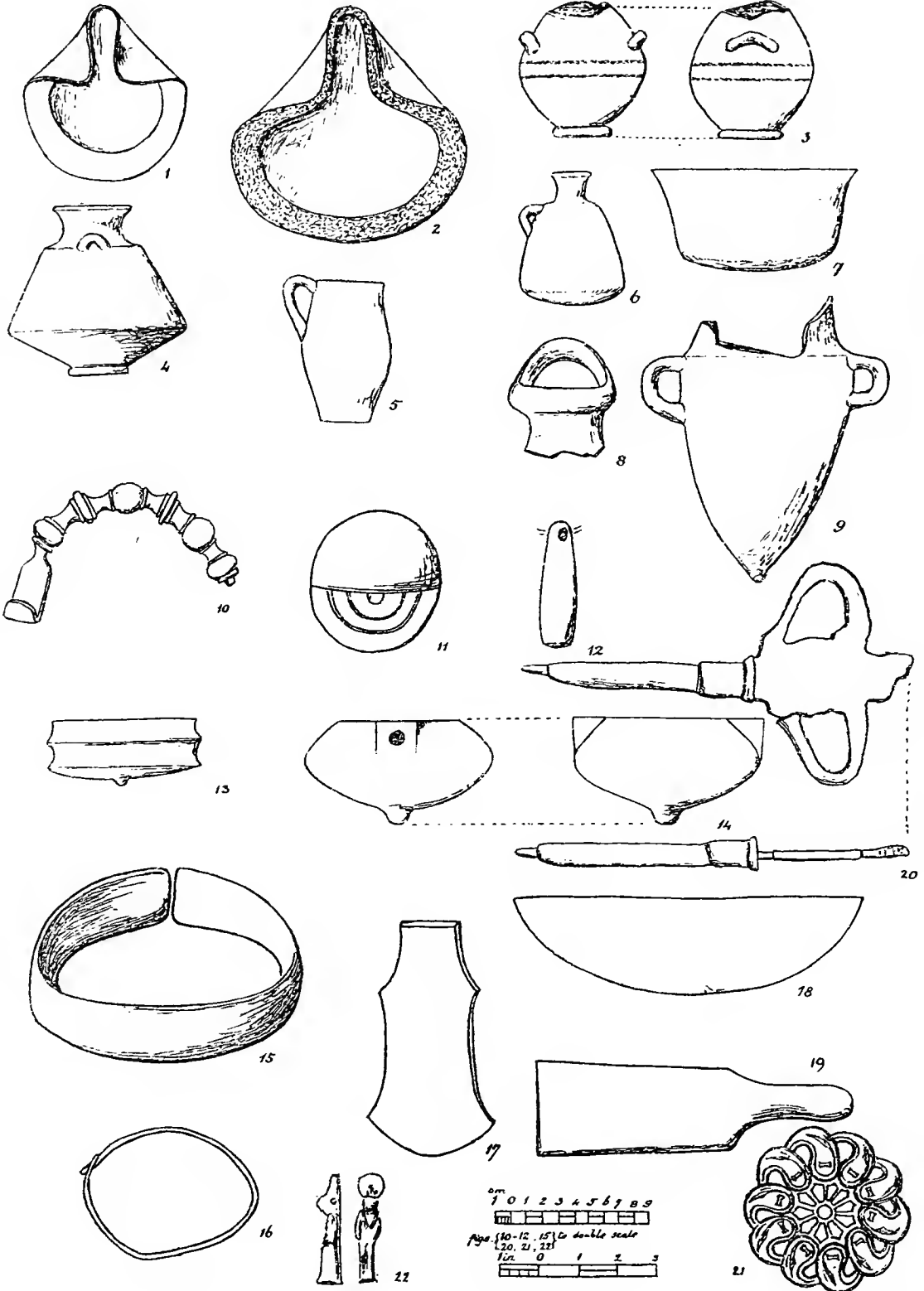

cm  
 1 0 1 2 3 4 5 6 7 8 9  
 10-12, 15, 16 double scale  
 20, 21, 22  
 in. 0 1 2 3

TOMB No. 96

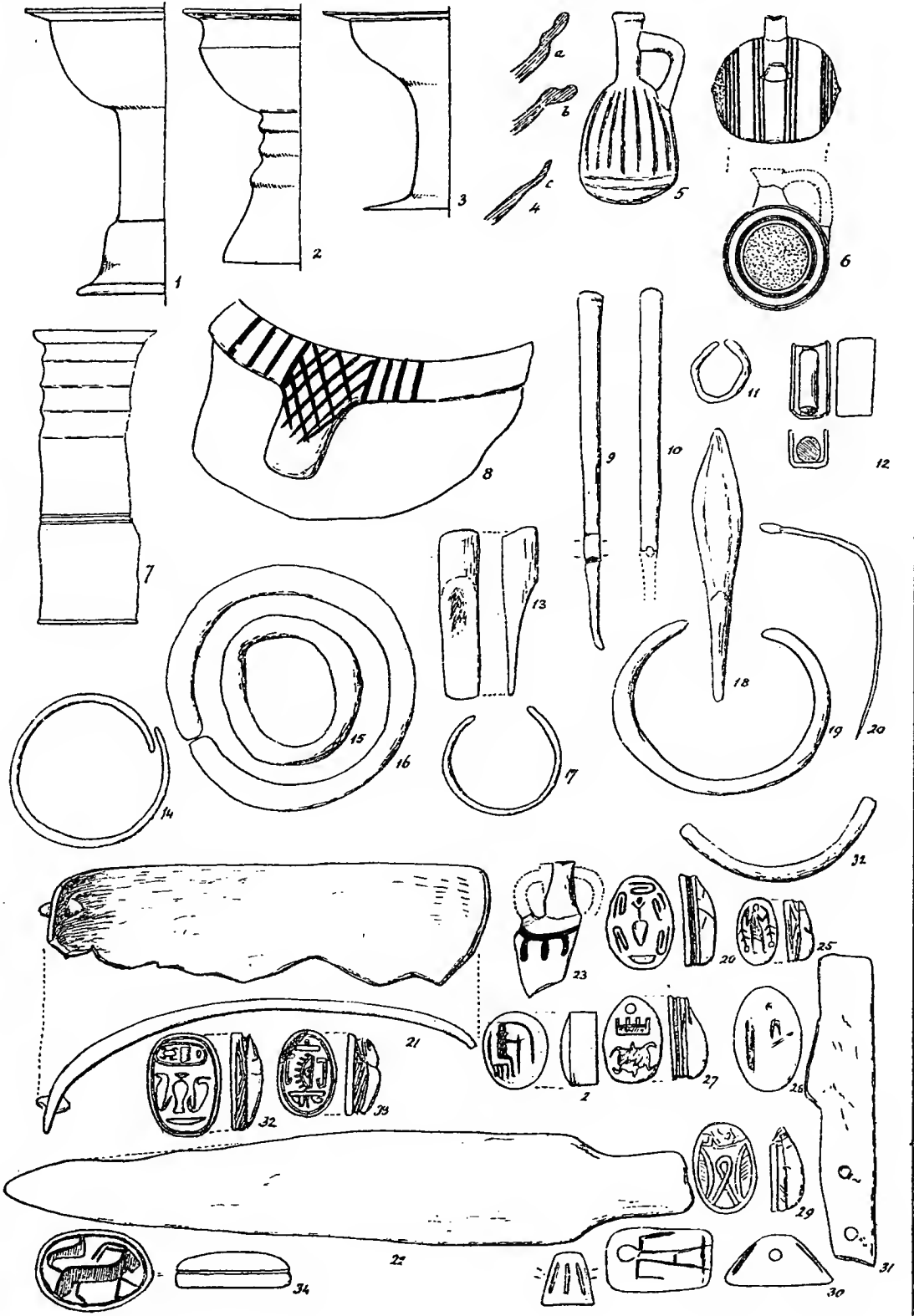







TOMB No. 96

0cm 5 10 15  
fig 18 and  
a-x 0  
0cm 1 2 3 4 5  
double scale.

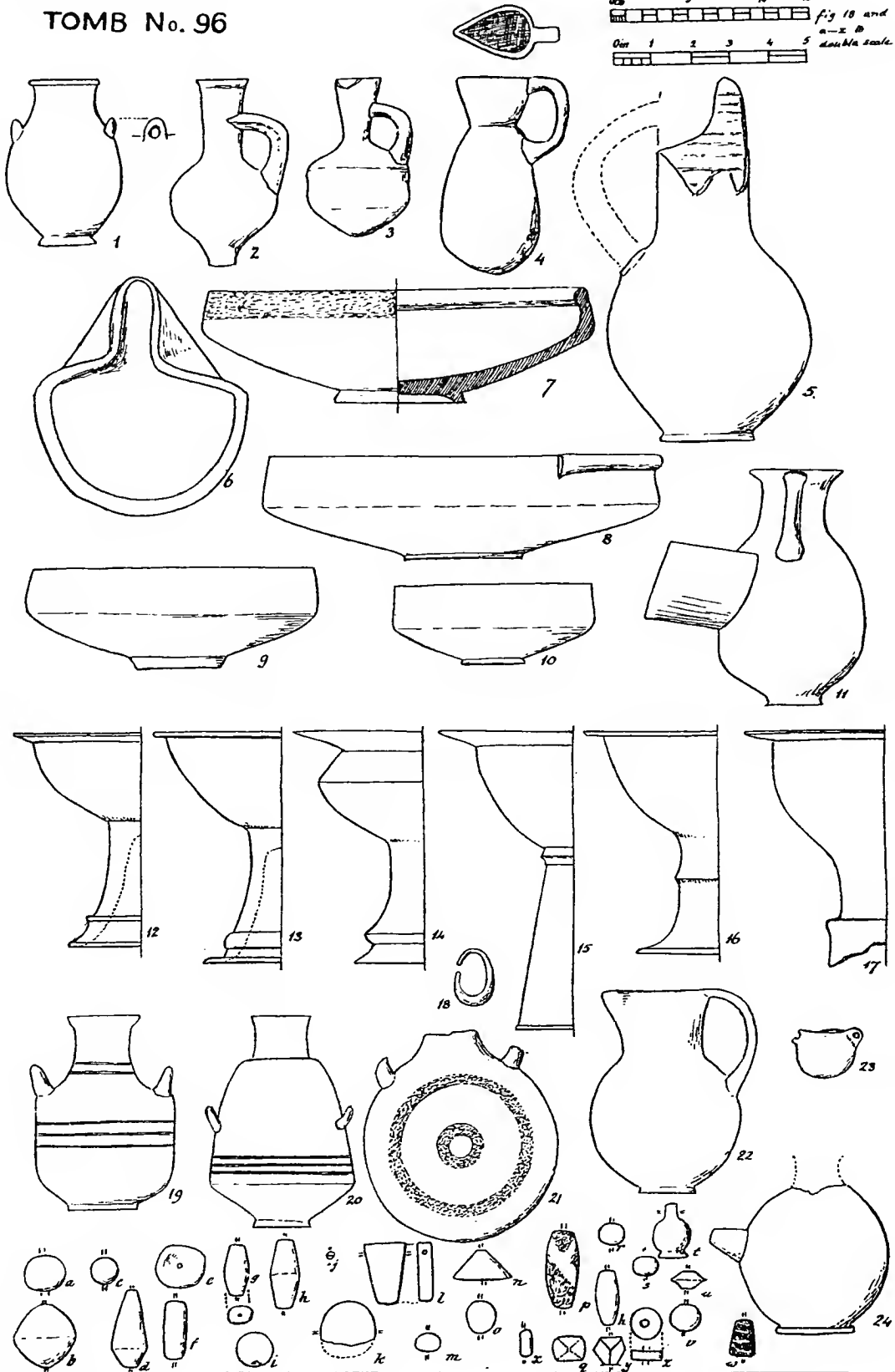

TOMB No. 99

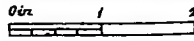
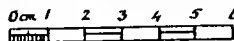
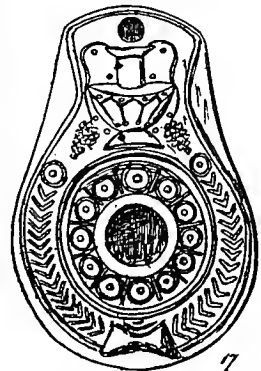
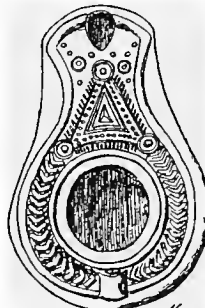
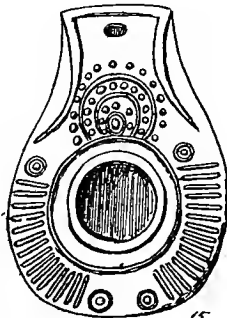
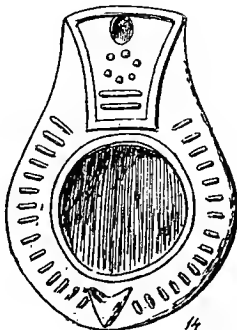
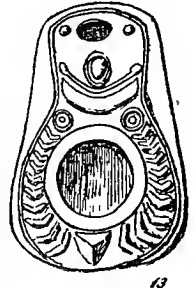
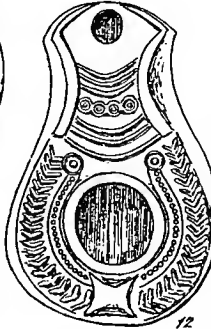
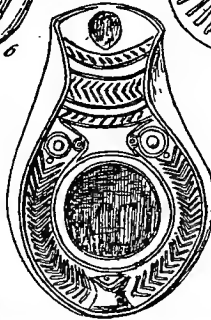
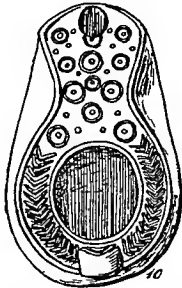
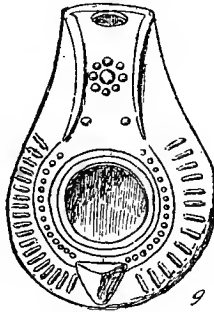
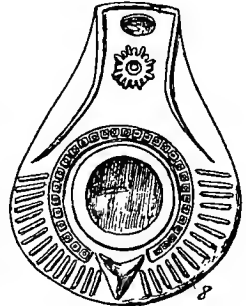
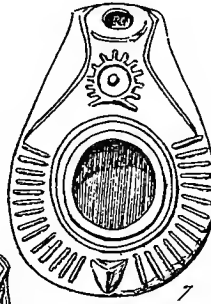
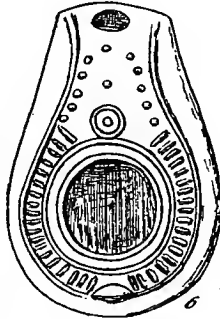
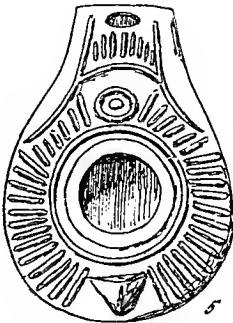
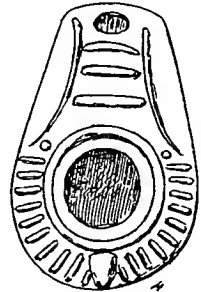
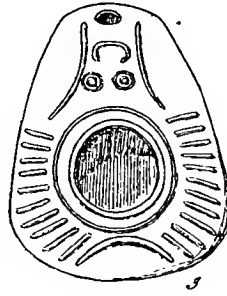
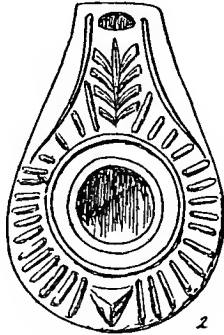
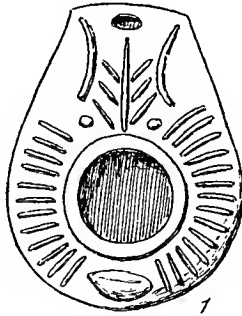





TOMB No. 99

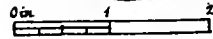
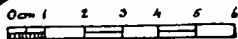
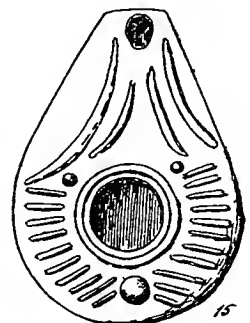
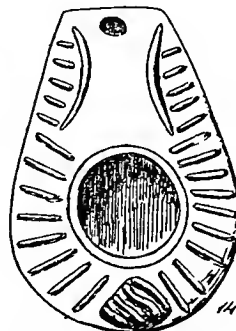
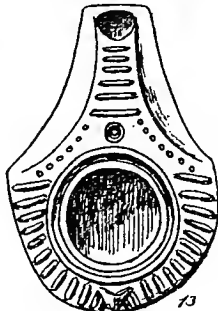
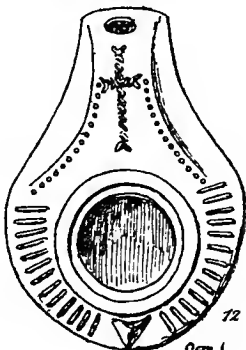
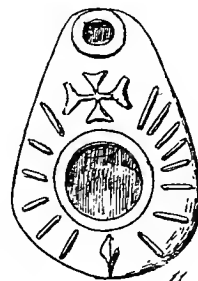
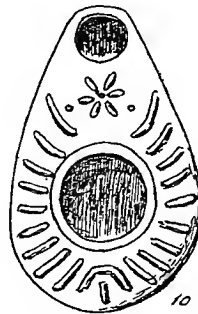
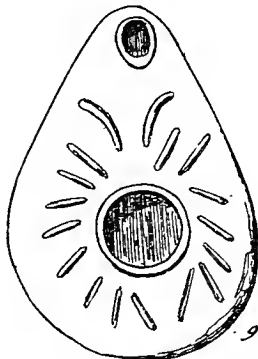
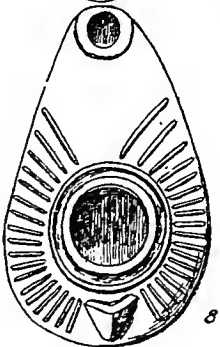
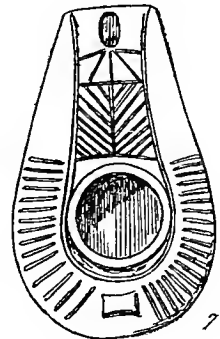
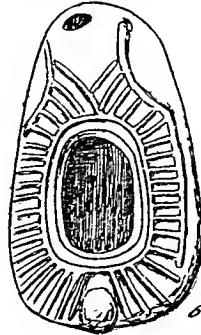
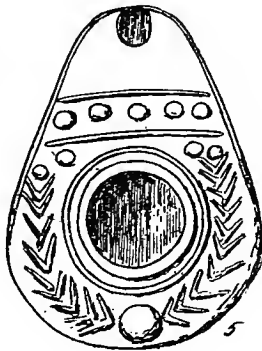
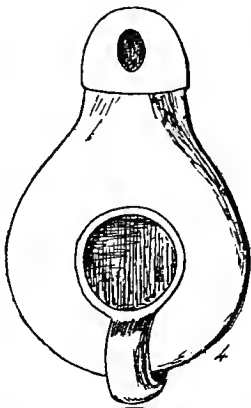
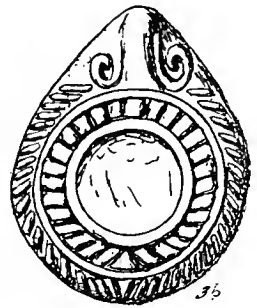
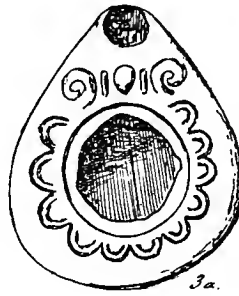
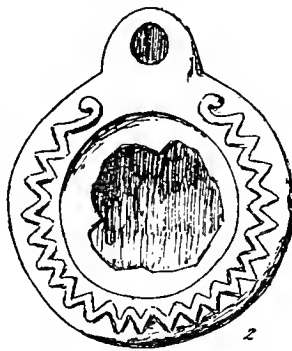
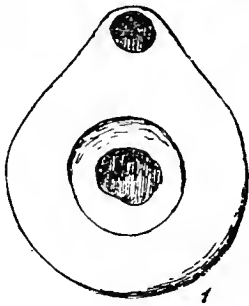

TOMB DEPOSITS

No. 99

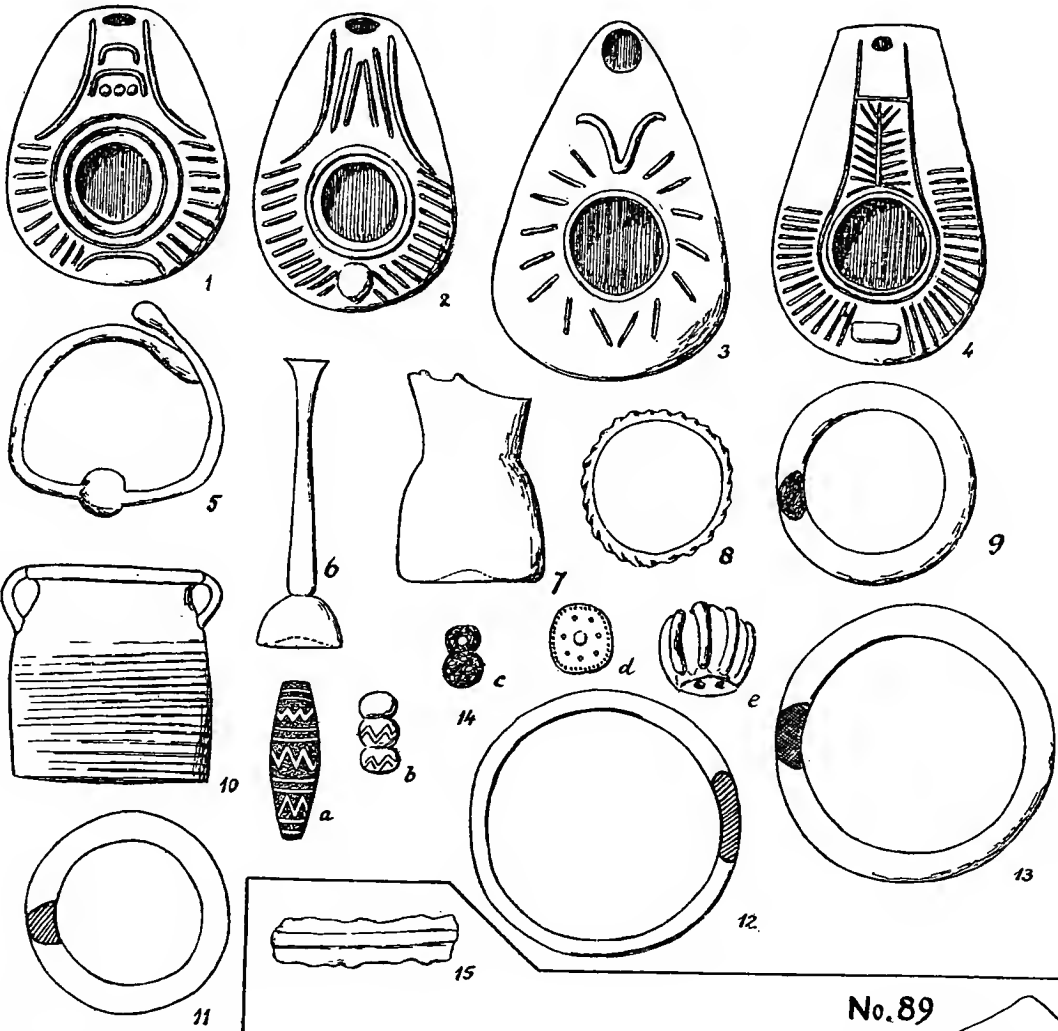

No. 89

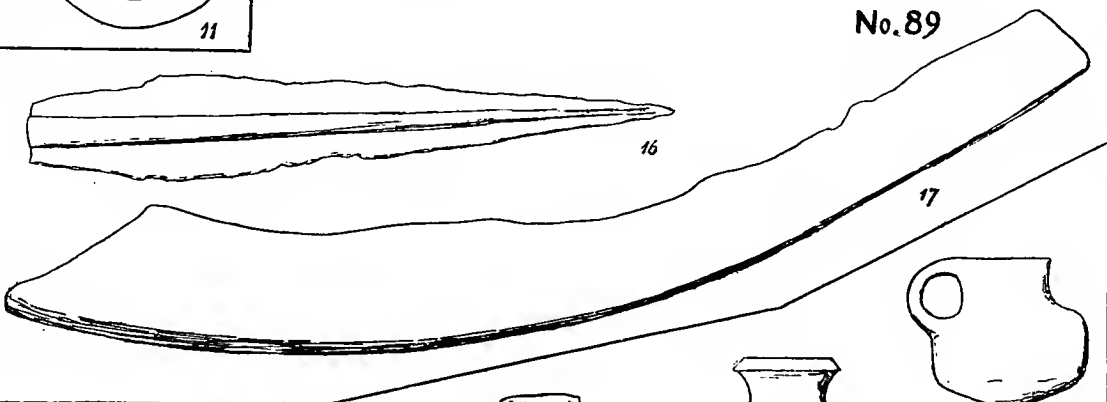

No. 82

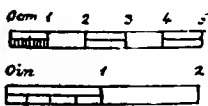

(figs 18-20 to half scale)

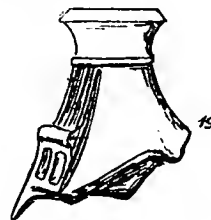







TOMB No 103

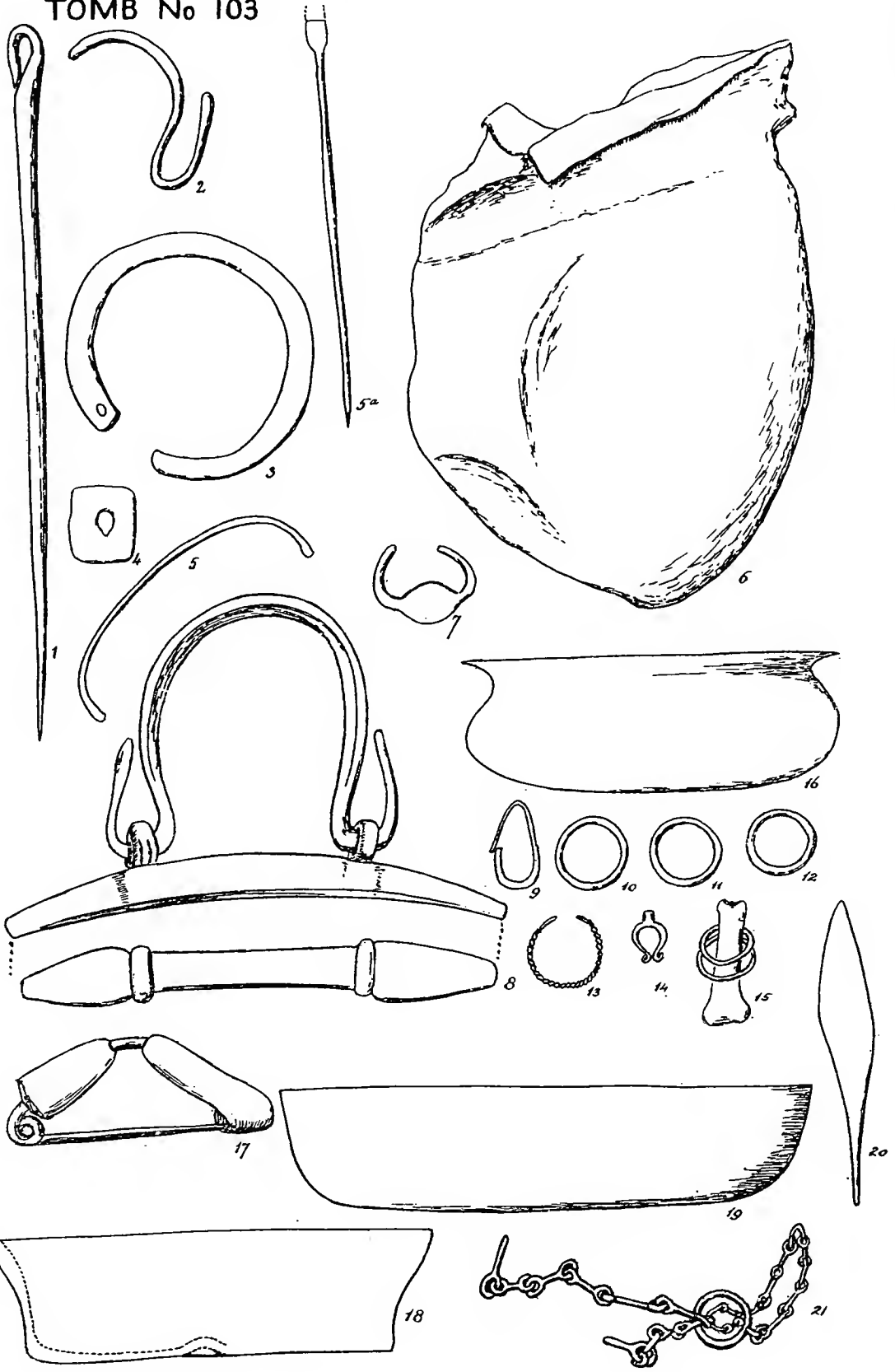

TOMB No. 103

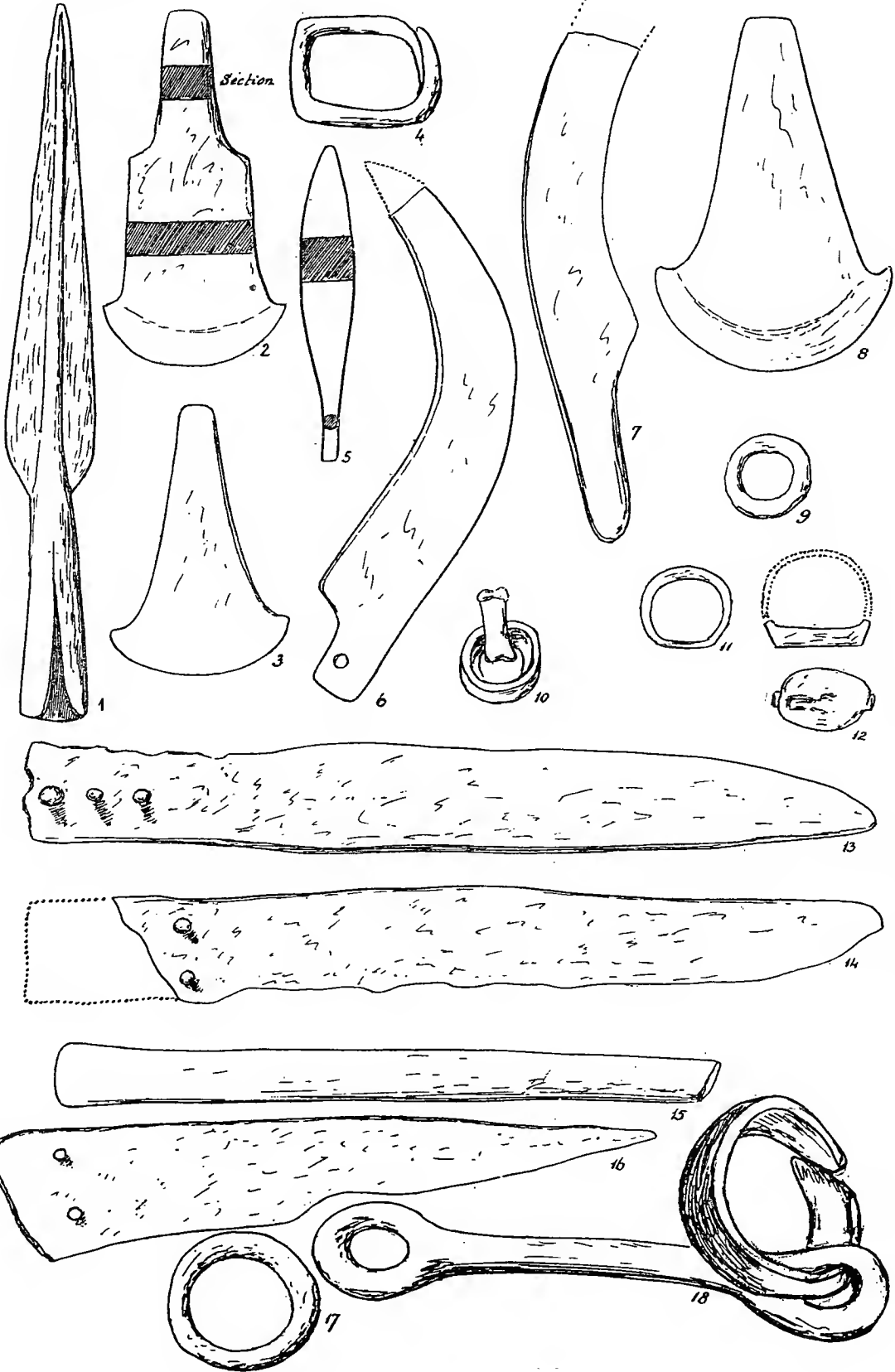







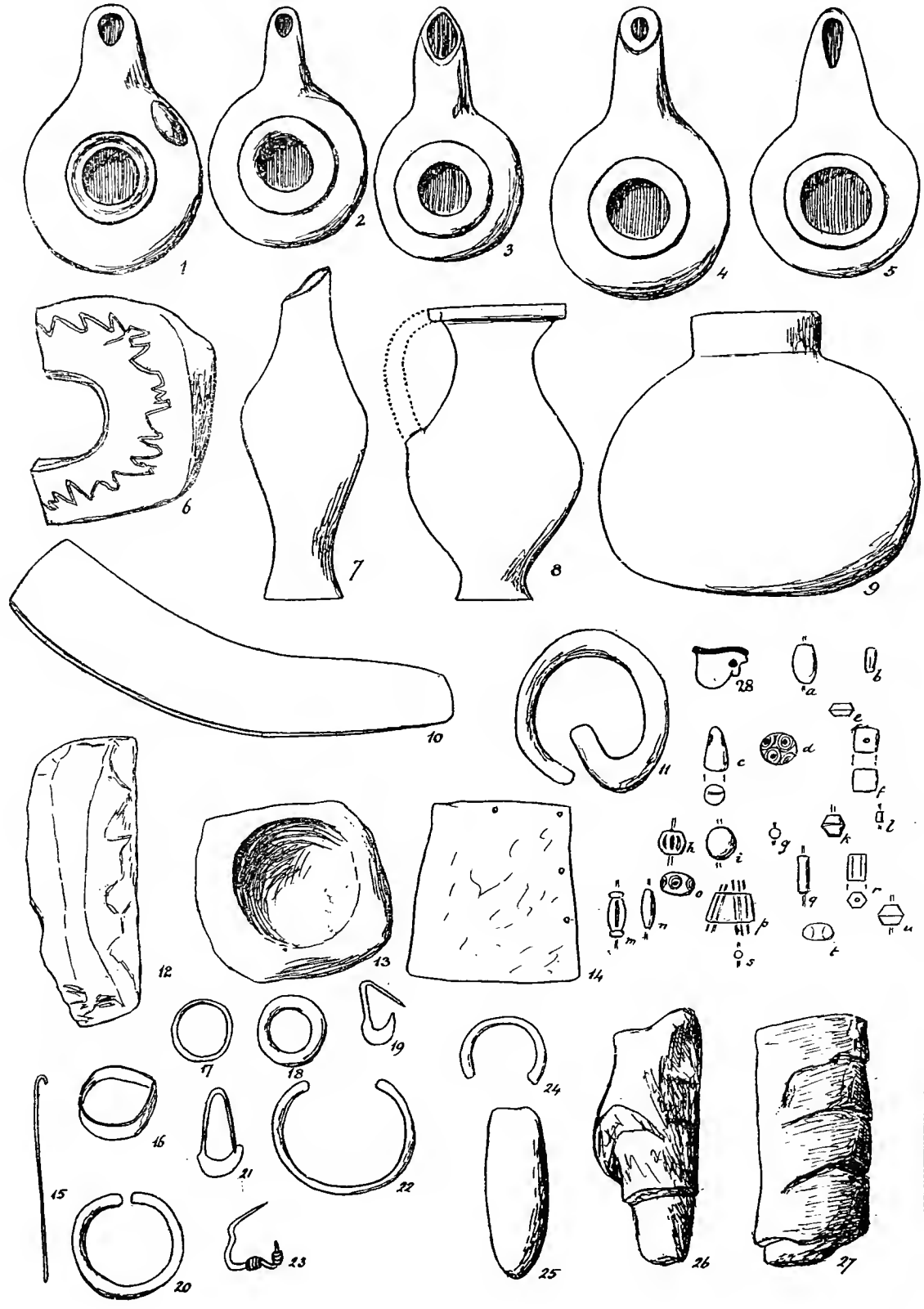

TOMB No. 103

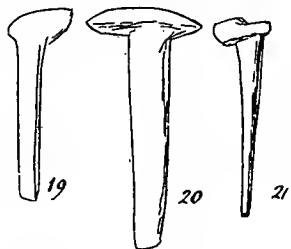
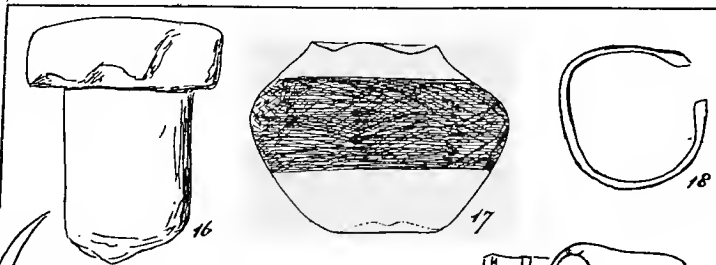
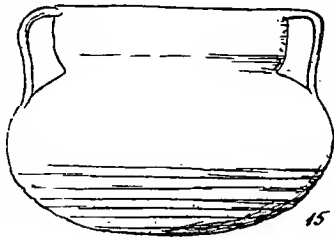
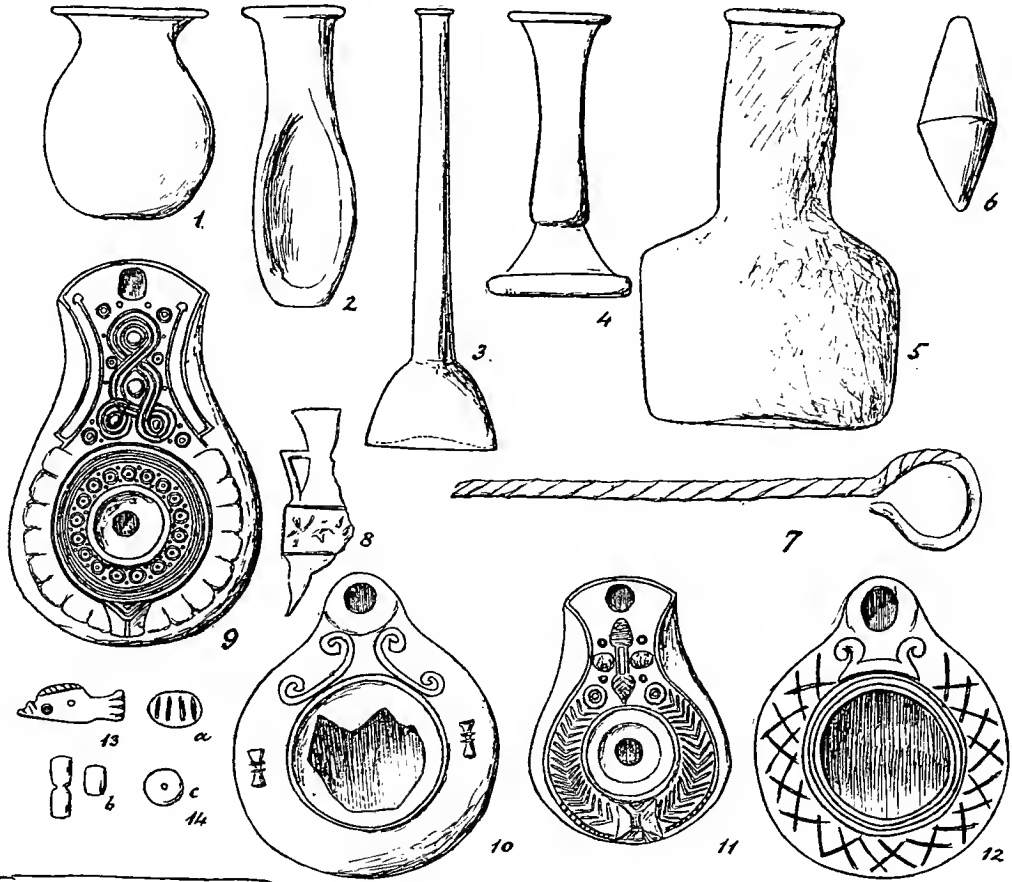

TOMB No 117



No. 124

 *a* red pottery  
 *b* bluish paste  
 *c* black glass (about 30 like these)  
 *d*

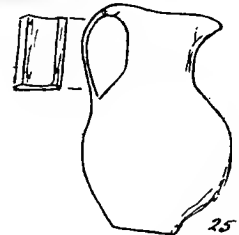

No. 150

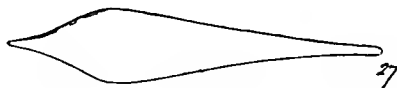







TOMB DEPOSITS

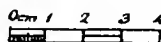
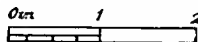

No. 118

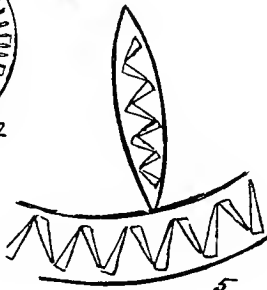
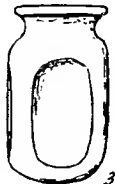
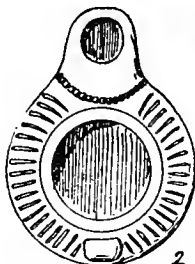
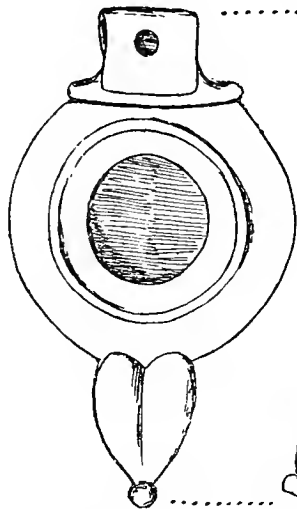

No. 128

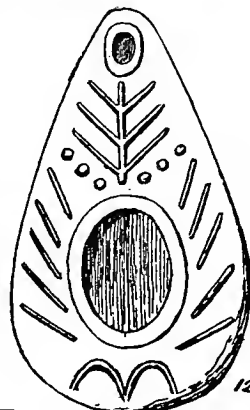
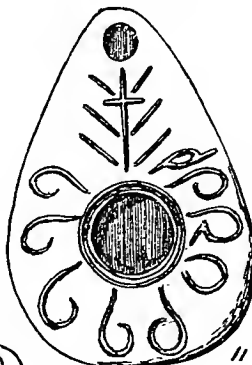
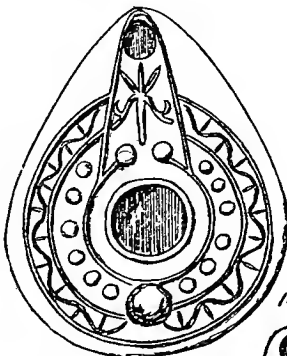
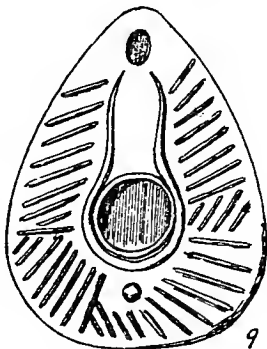
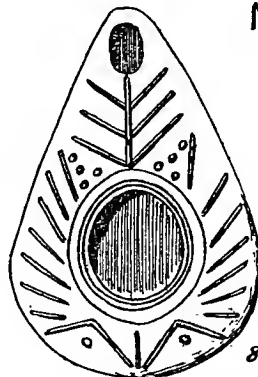
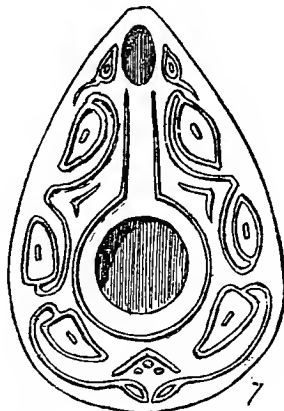
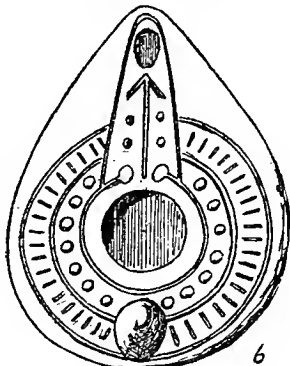

No 213

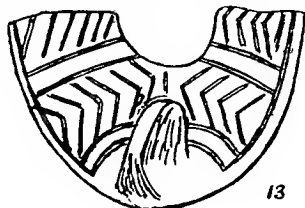

No. 158

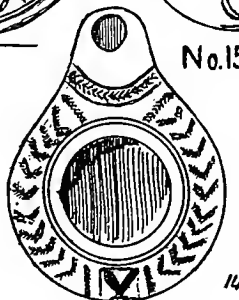

No. 169



TOMB DEPOSITS

figs 2-4, 17, 18, 20, 24, 25, 27-31 to double scale.

No. 131

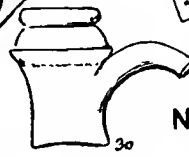
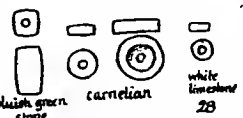
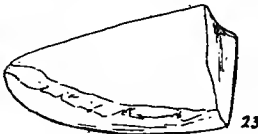
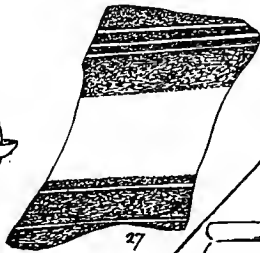
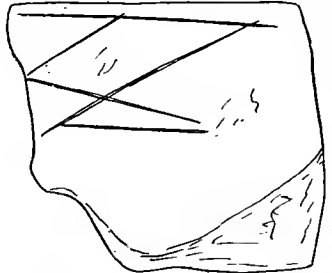
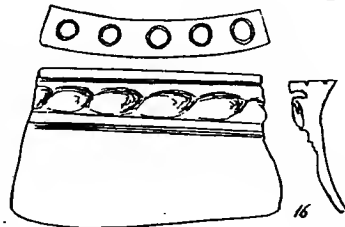
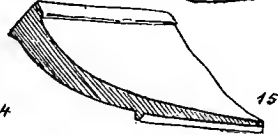
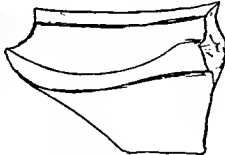
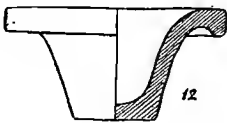
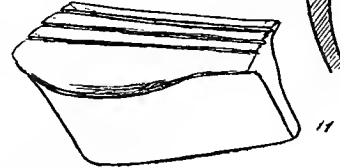
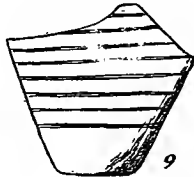
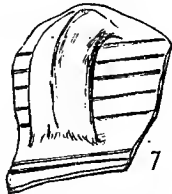
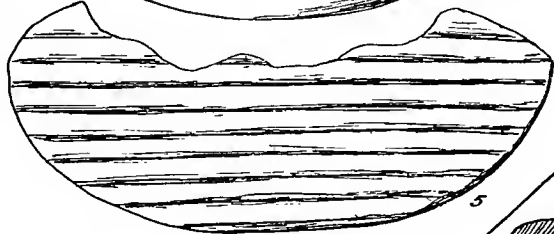
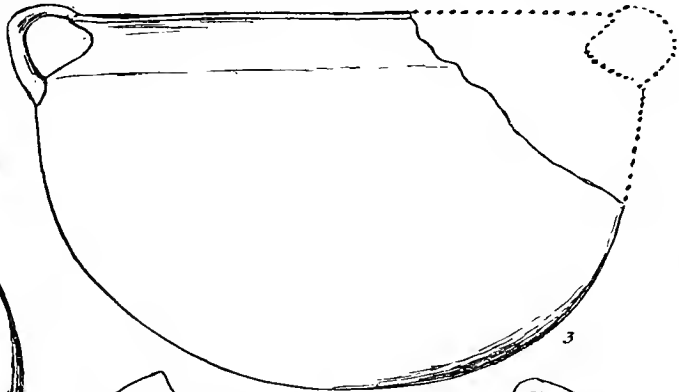
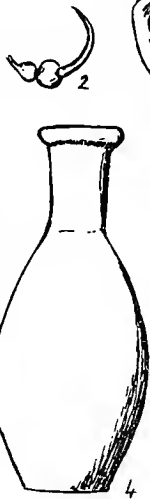
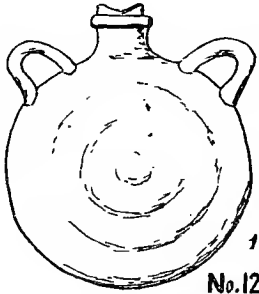

No. 80

Muslim green stone  
carnelian  
white limestone





TOMB No 124

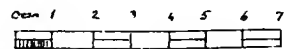

for dimensions of figs 17, 18, see descriptions

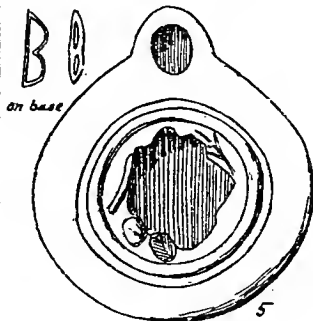
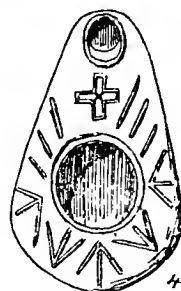
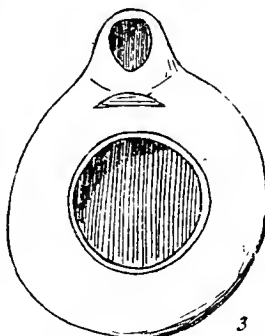
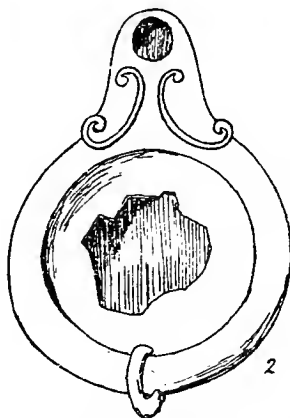
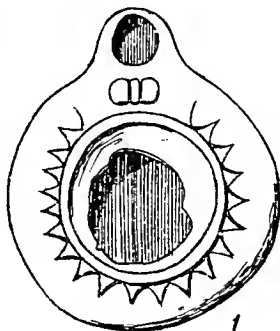

UXL CRL  
on base of 2

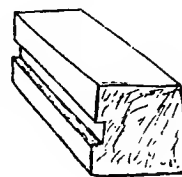
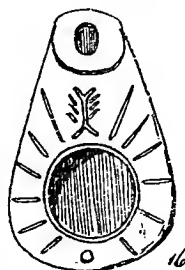
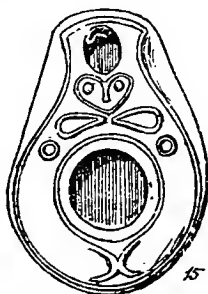
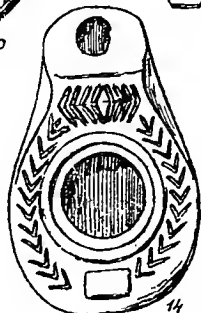
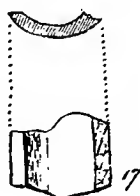
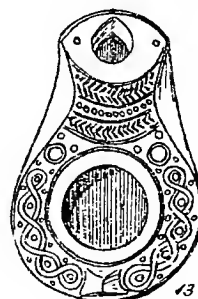
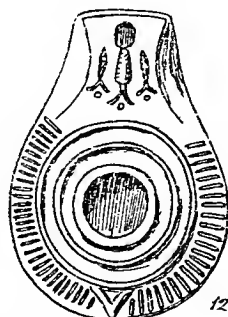
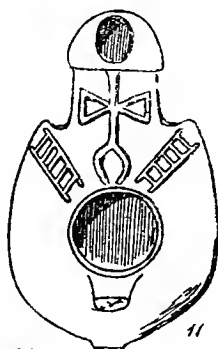
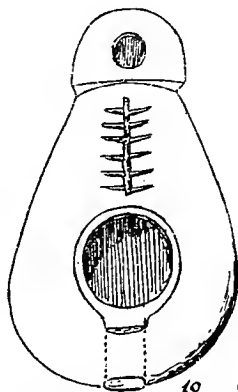
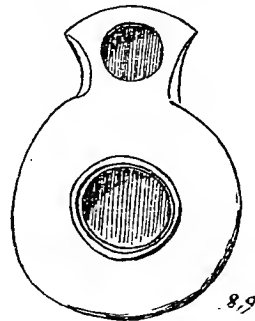
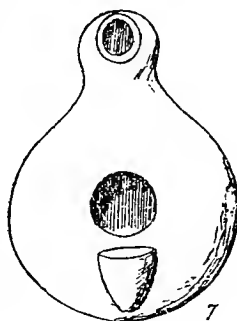
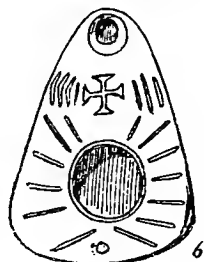

TOMB DEPOSITS

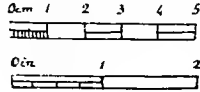

No. 134

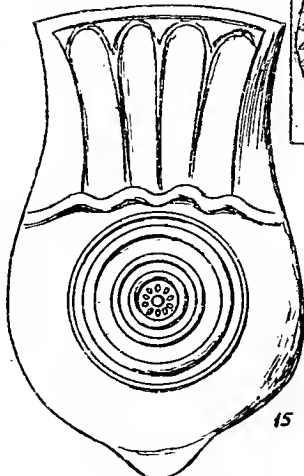
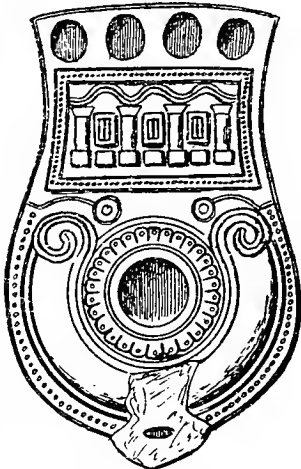
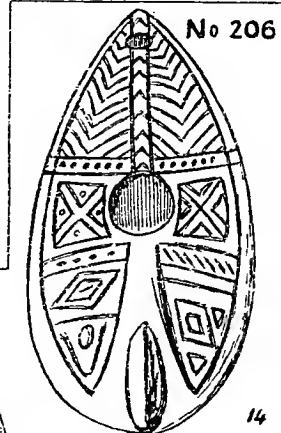
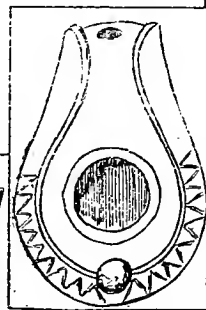
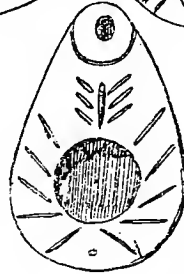
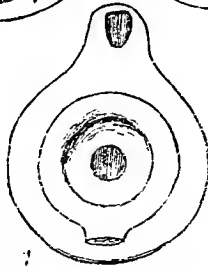
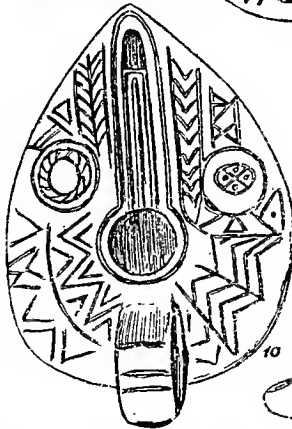
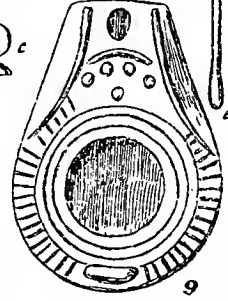
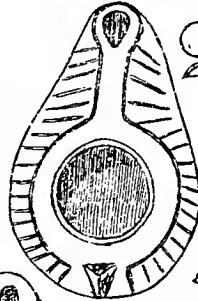
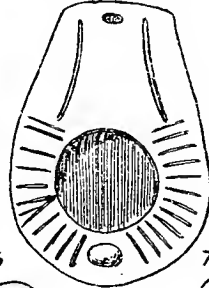
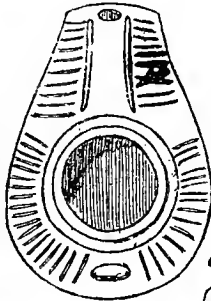
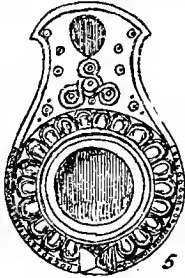
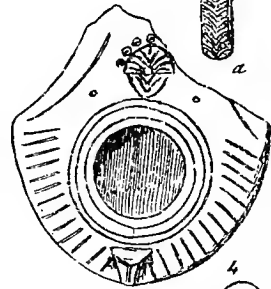
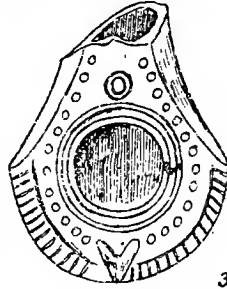
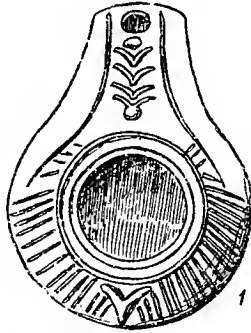

No. 36 (see also plate bovii)

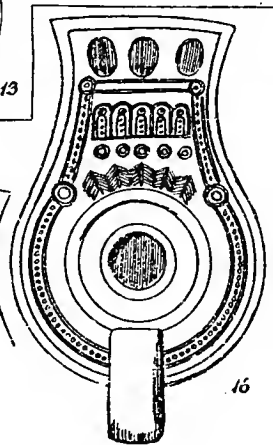
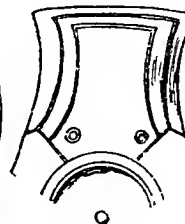







TOMB DEPOSITS

No. 138

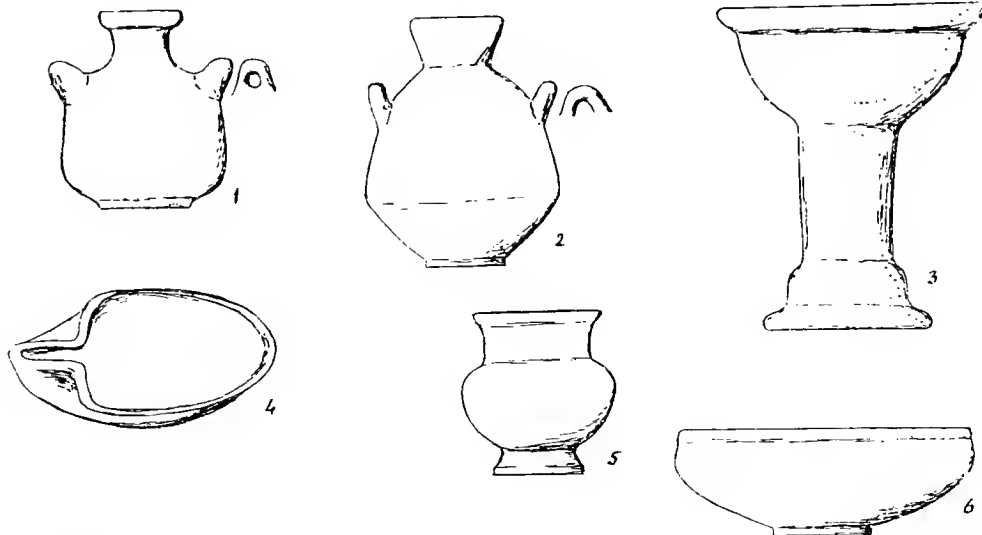

No. 139

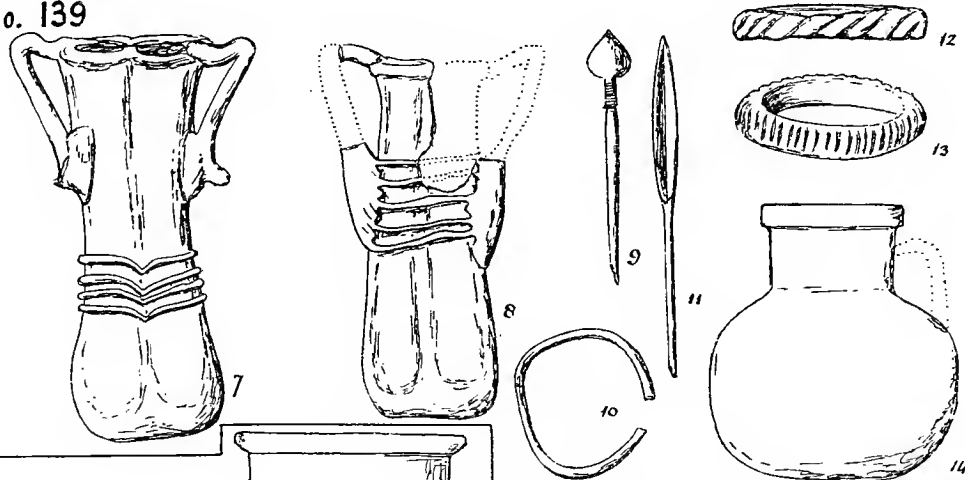

No. 7

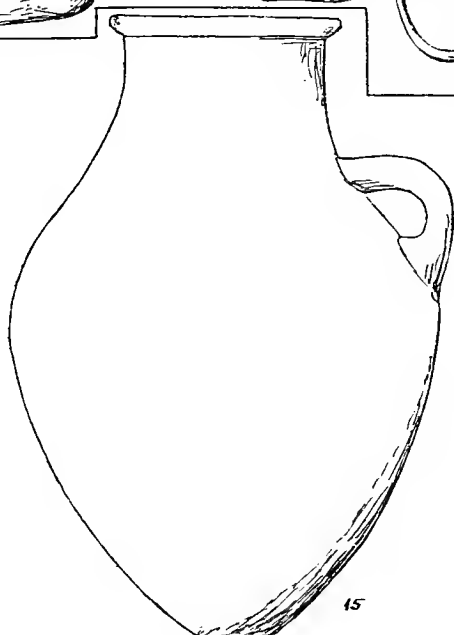

No. 144

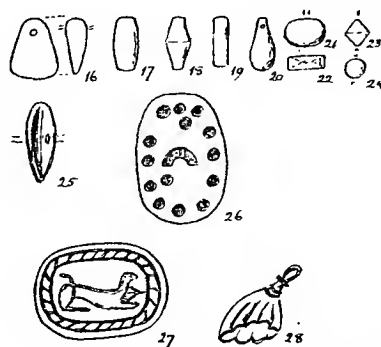
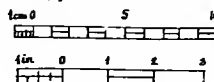

fig. 14 to half scale, figs 7-13, 16-25, 28 double, 26, 27 four times



TOMB No. 142







TOMB No. 147

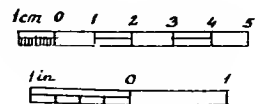
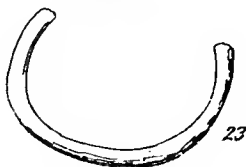
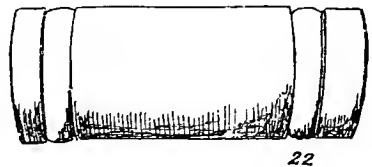
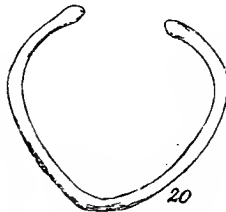
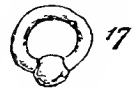
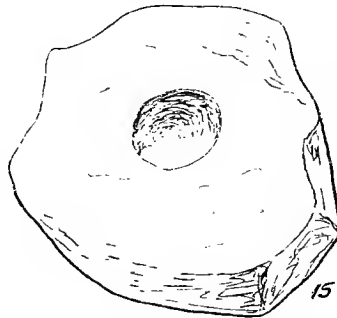
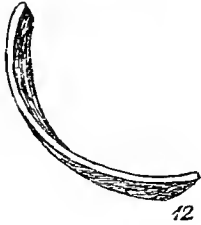
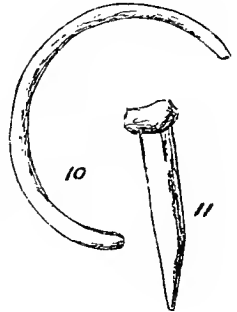
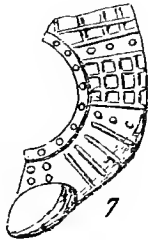
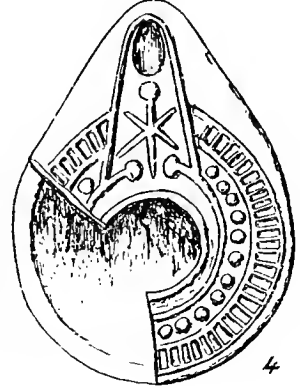
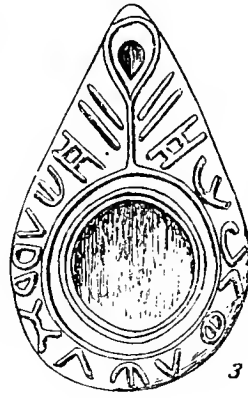
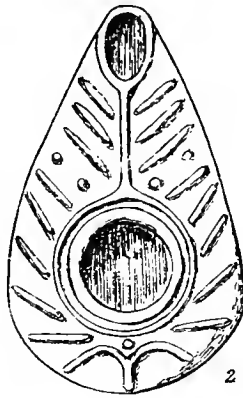
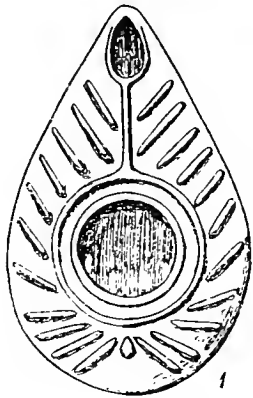

# TOMB No 147

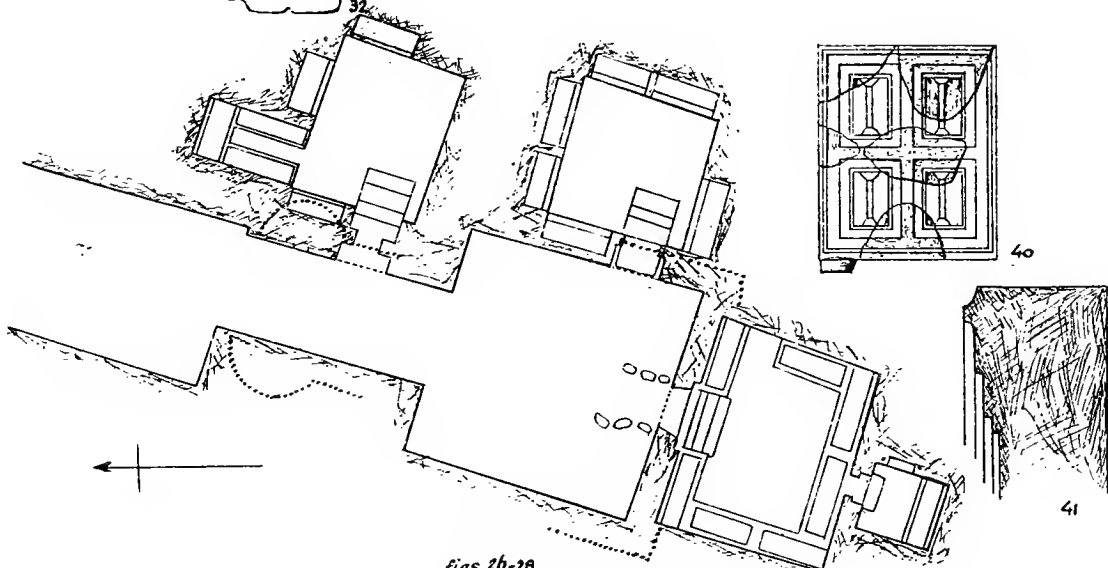
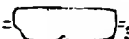
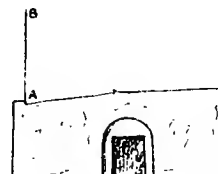
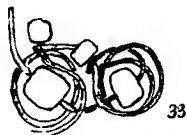
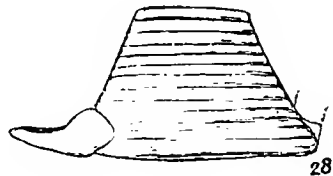
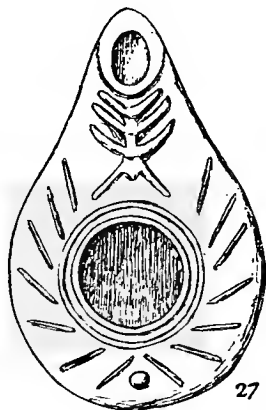
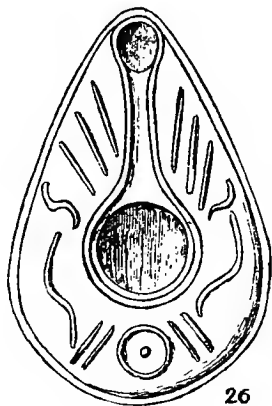

figs 26-28

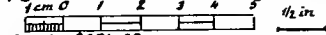

figs. 29-32, 34-38

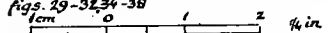

fig. 33

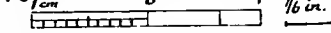

fig. 40

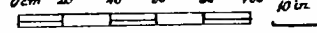
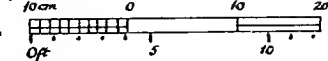

fig 41



figs. 39, 42









TOMB DEPOSITS

No. 152

No. 143

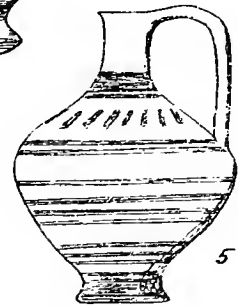
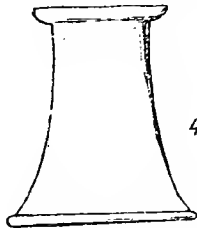
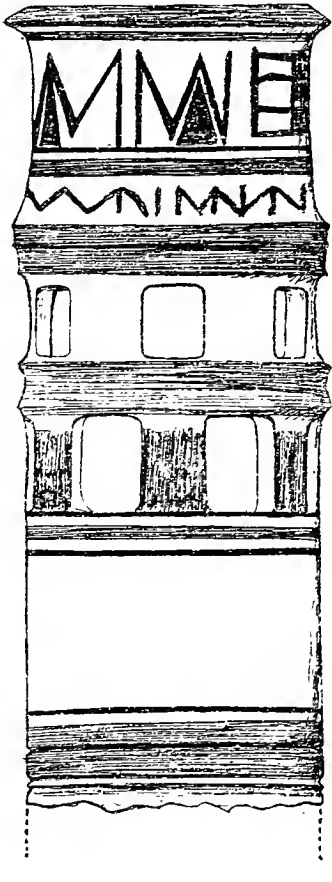
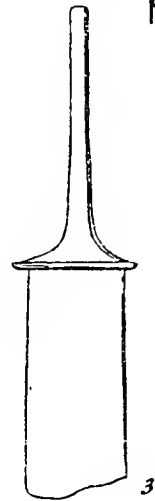
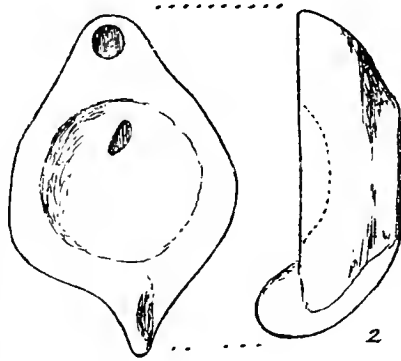
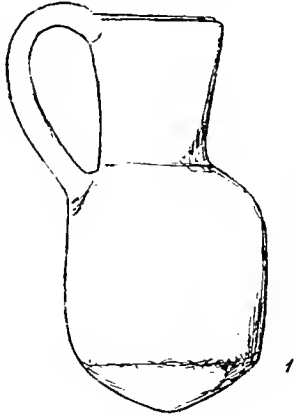

*this object from tomb 142*

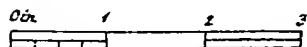
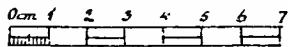

No. 66



No. 194

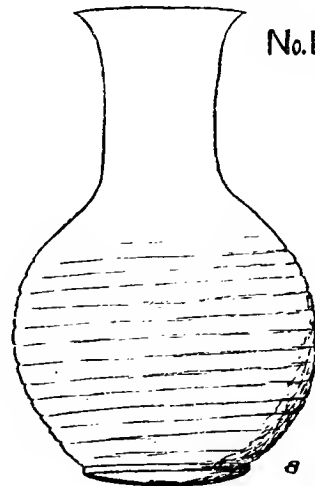

TOMB DEPOSITS

figs 1-5, 20, 23, 24 half scale; 6-19 double scale.

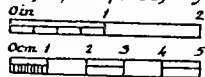

No. 153

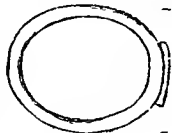
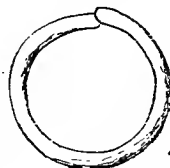
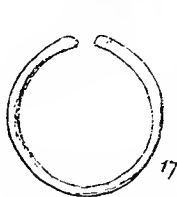
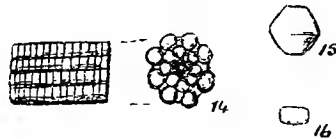
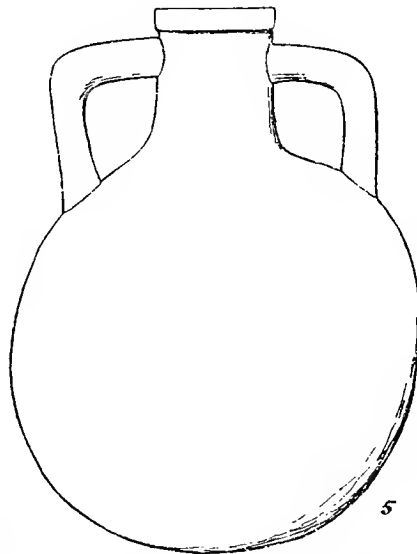
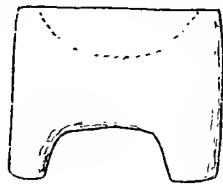
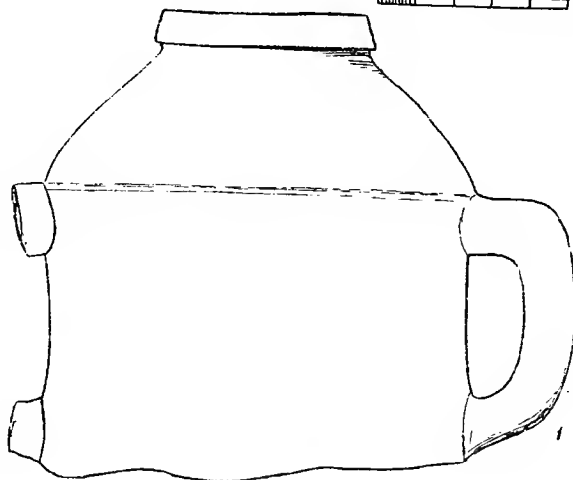

No. 242



No. 227

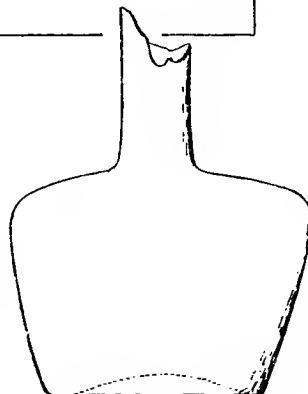





# TOMB No. 156

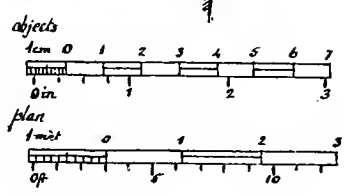
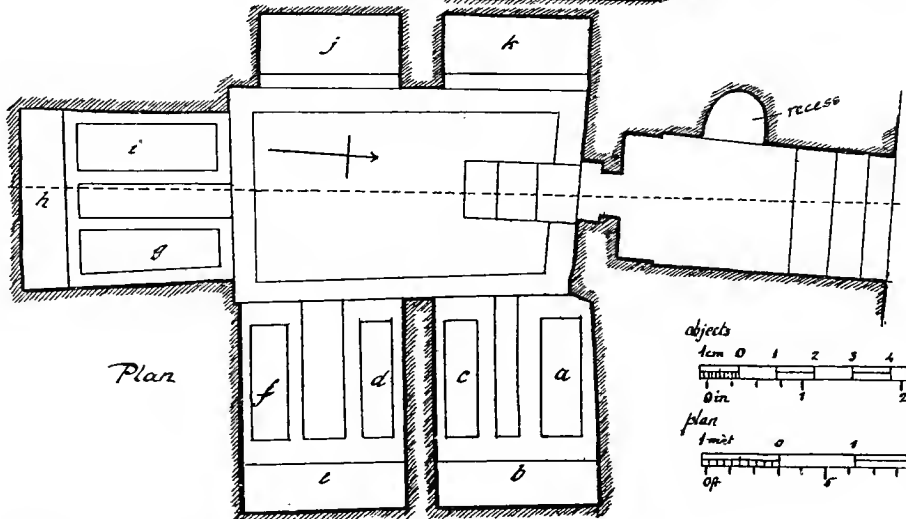
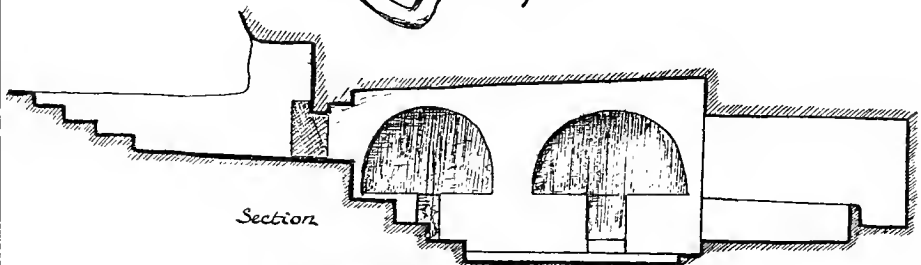
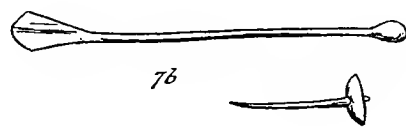
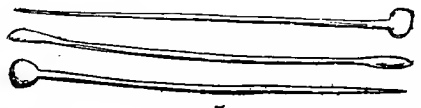
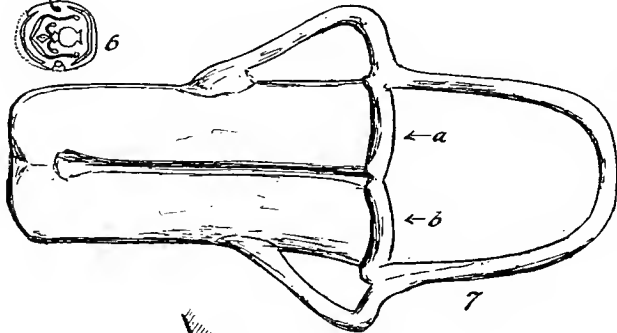
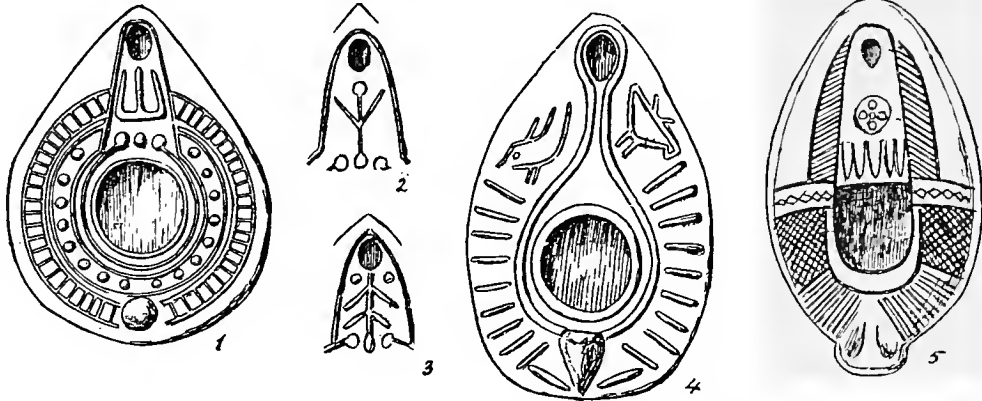

TOMB DEPOSITS

No.157

No.218

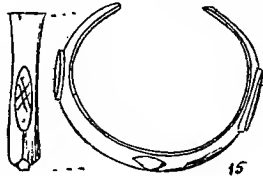
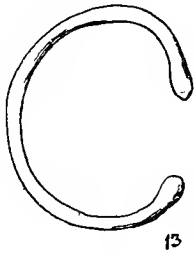
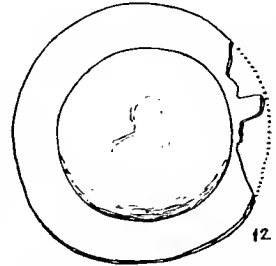
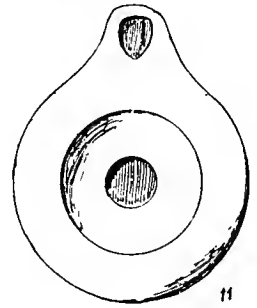
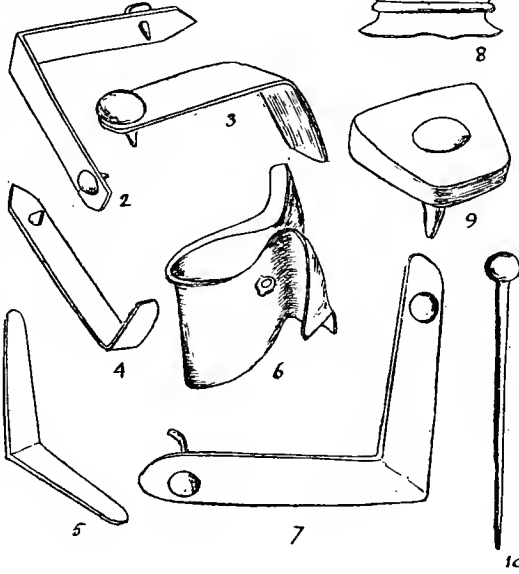
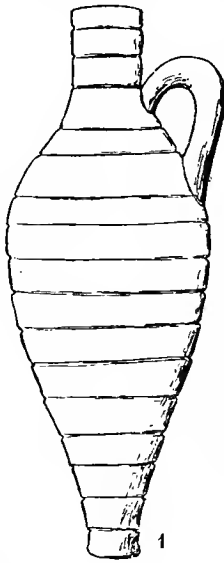

No.76

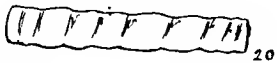
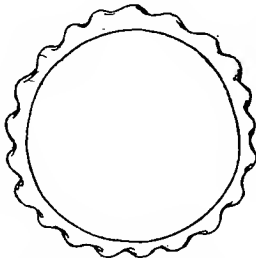
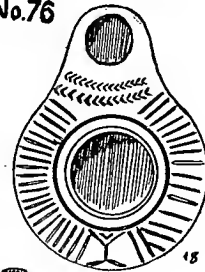

No.148

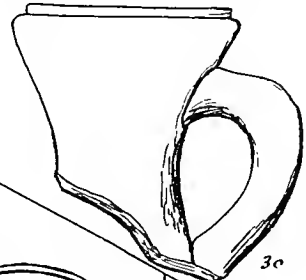

No.145

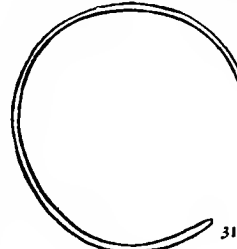

No.201

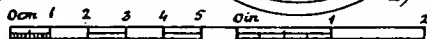
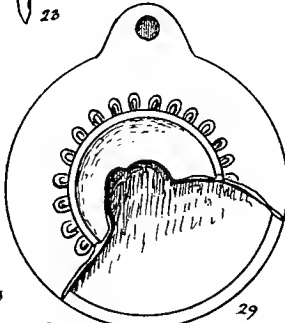
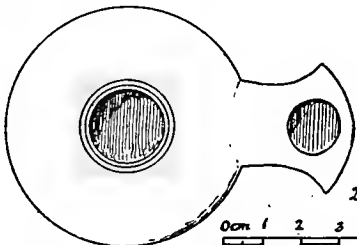

fig. 8 to half scale







# TOMB No. 160

(TOMB OF STEPHANOS PHILOCHRISTOS)

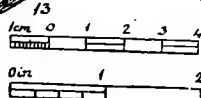
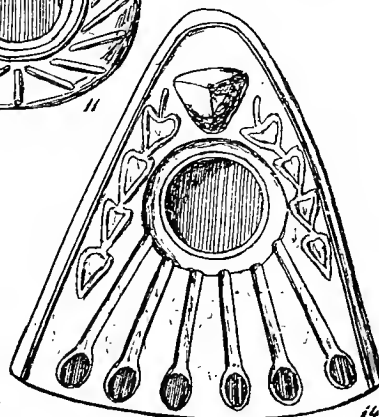
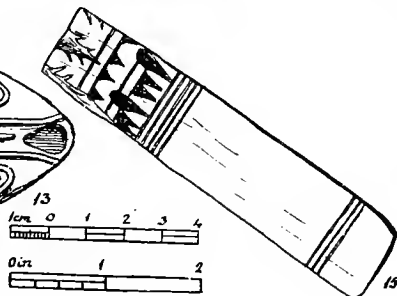
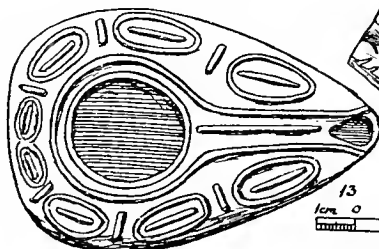
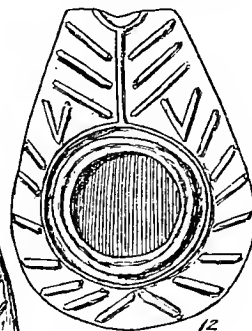
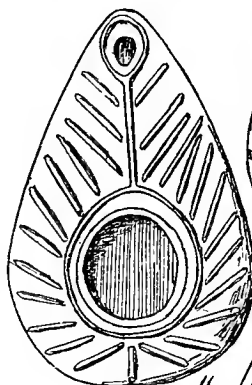
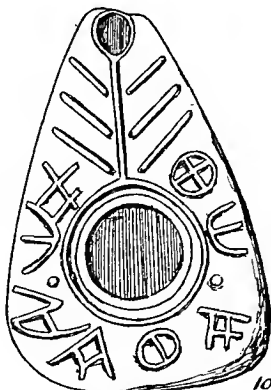
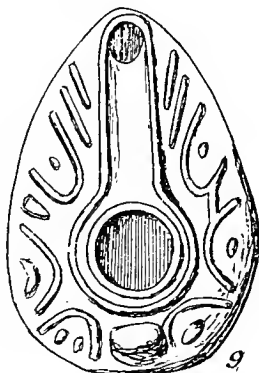
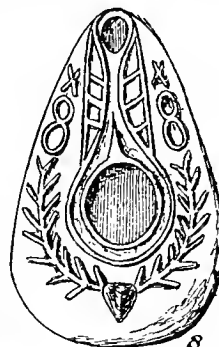
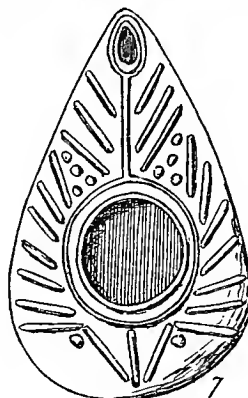
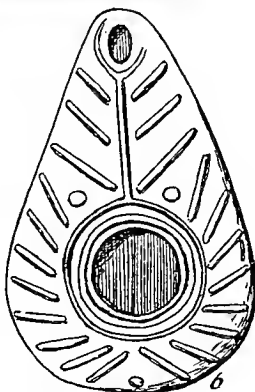
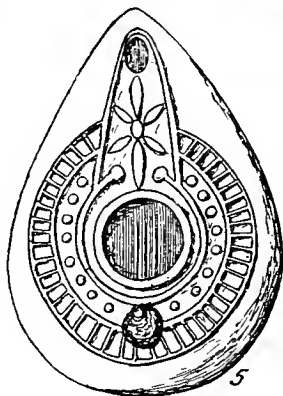
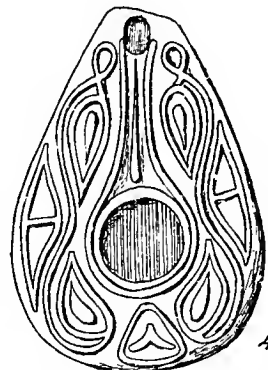
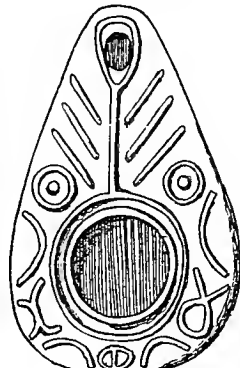
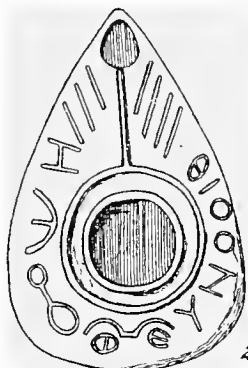
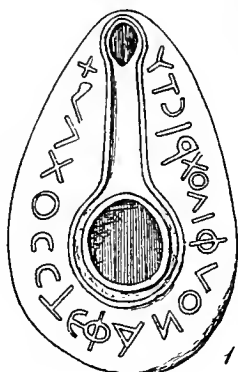

TOMB No. 160

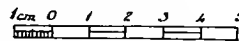
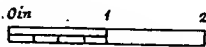
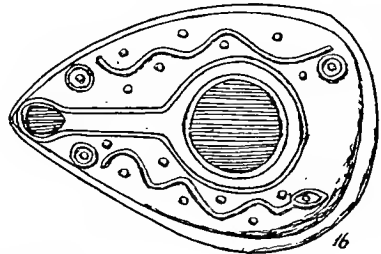
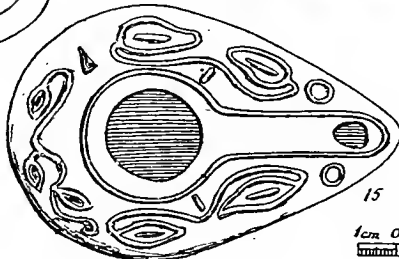
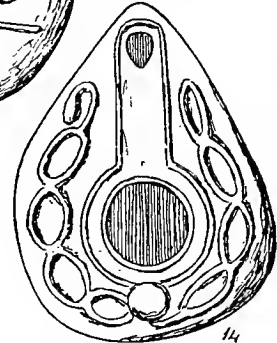
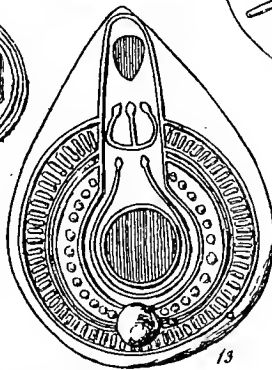
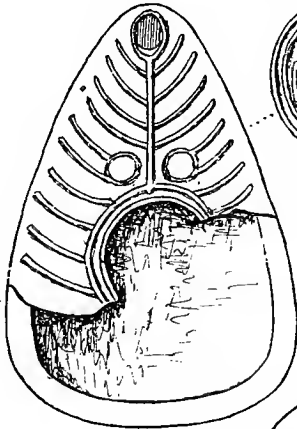
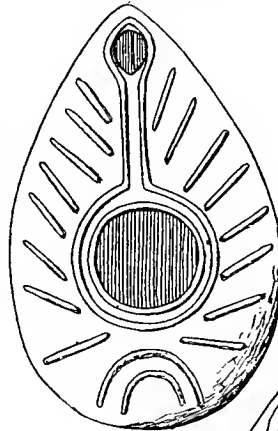
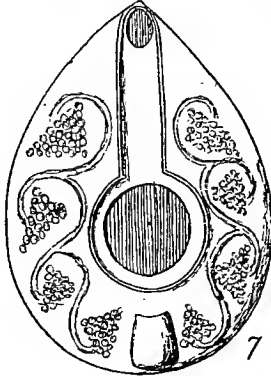
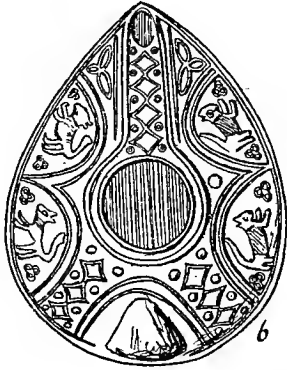
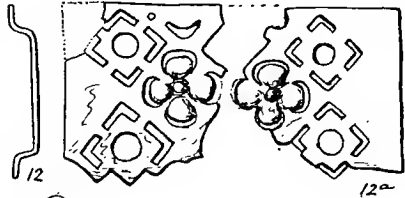
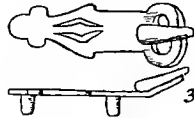
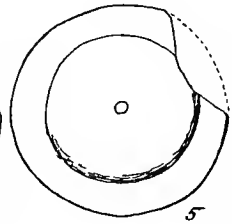
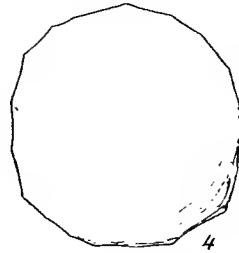
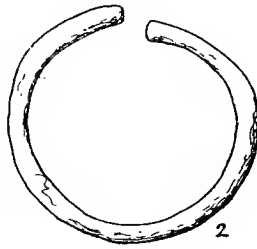
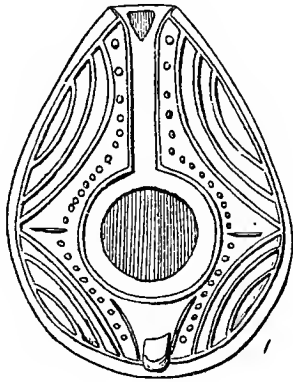





# TOMB No. 160

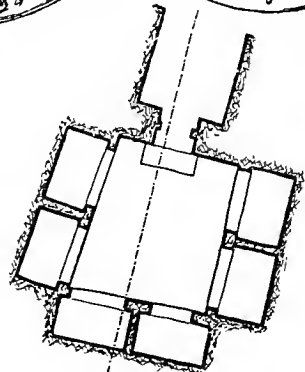
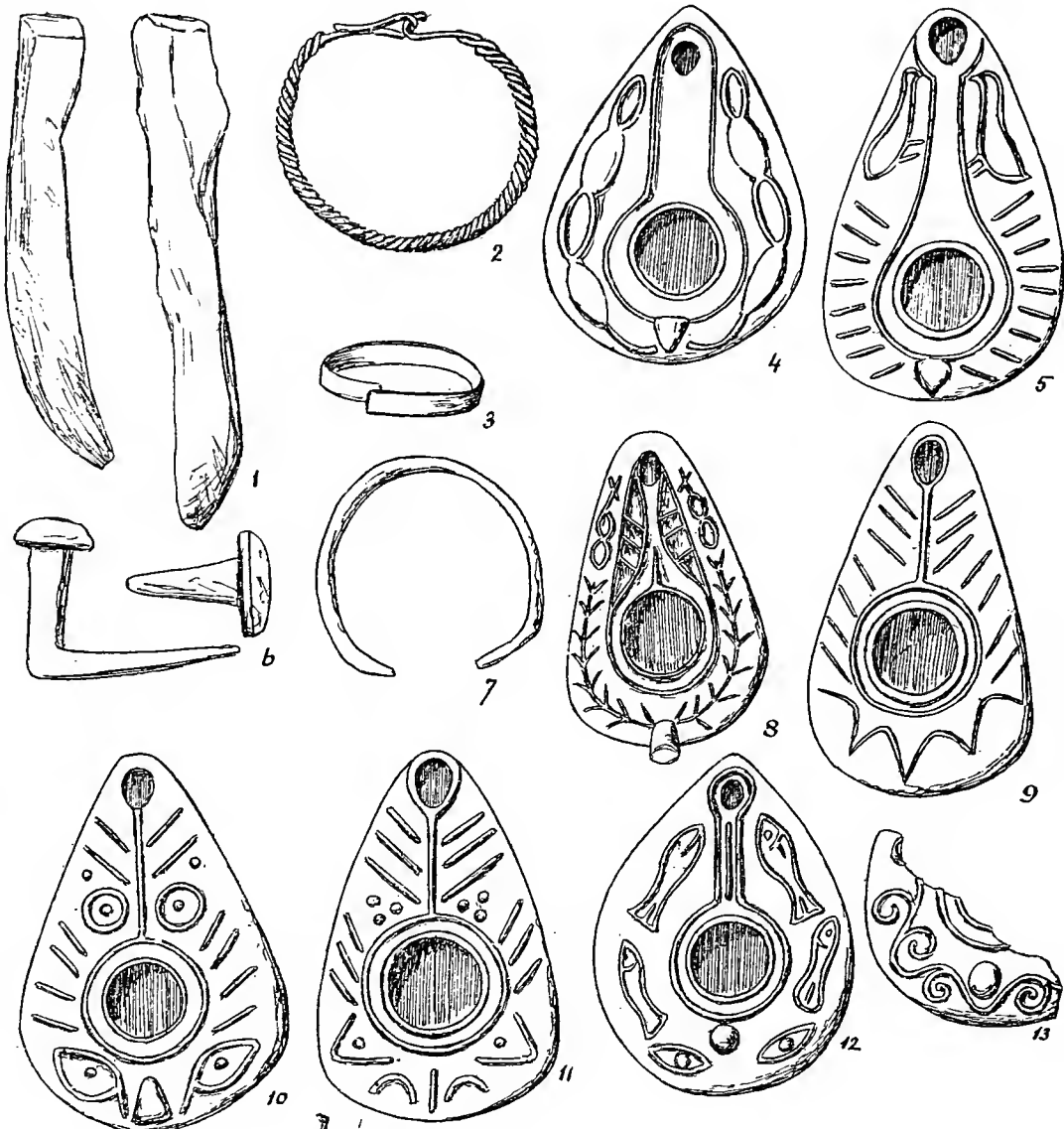

Plan

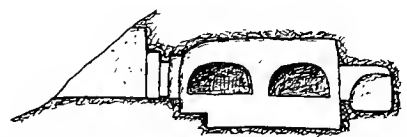

Entrance

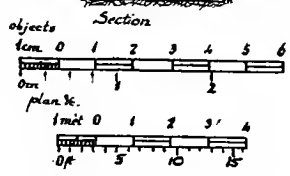

objects  
1 cm. 0 1 2 3 4 5 6  
of  
plan 1/20  
1 mit 0 1 2 3' 4  
of 5 10 15

TOMB DEPOSITS

No. 167

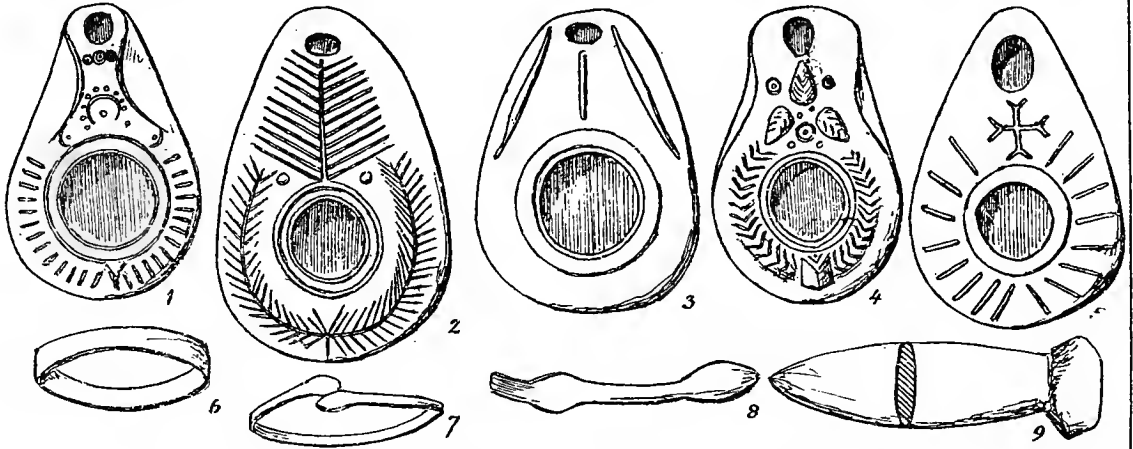

No. 155

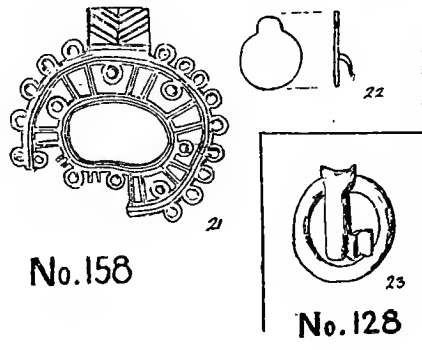
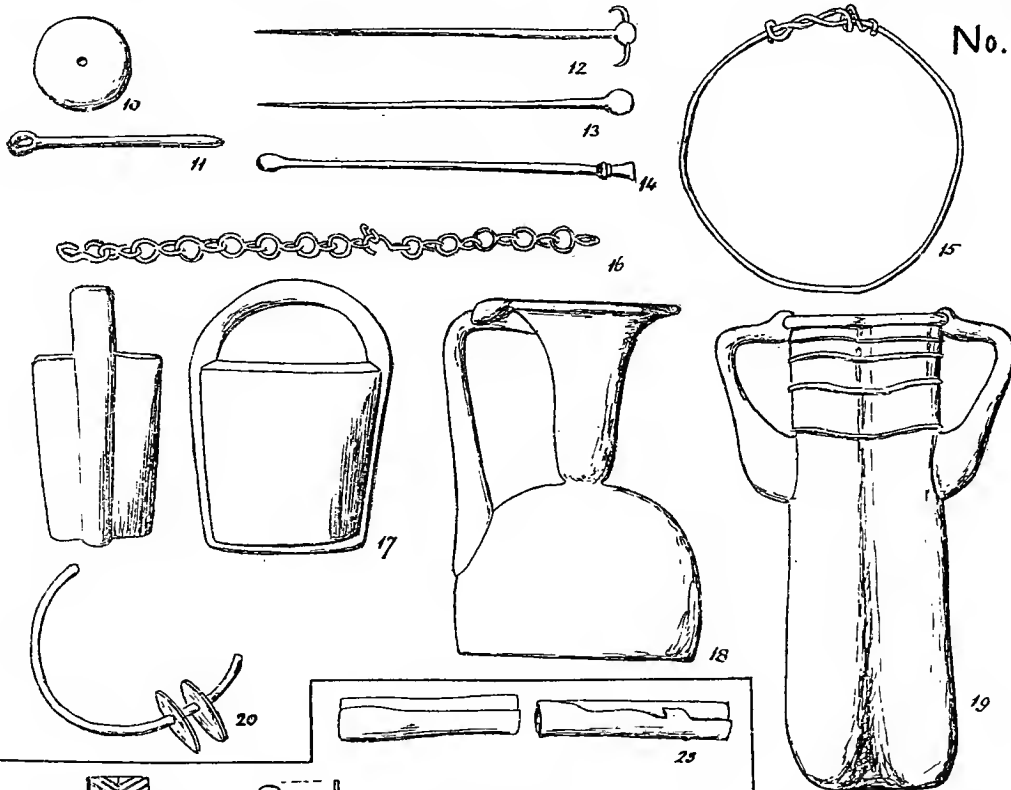

No. 158

No. 128

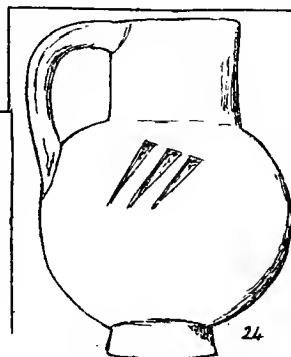

No. 129

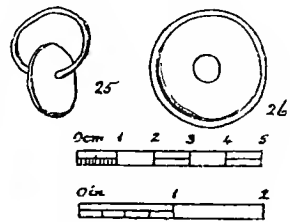







TOMB No 176

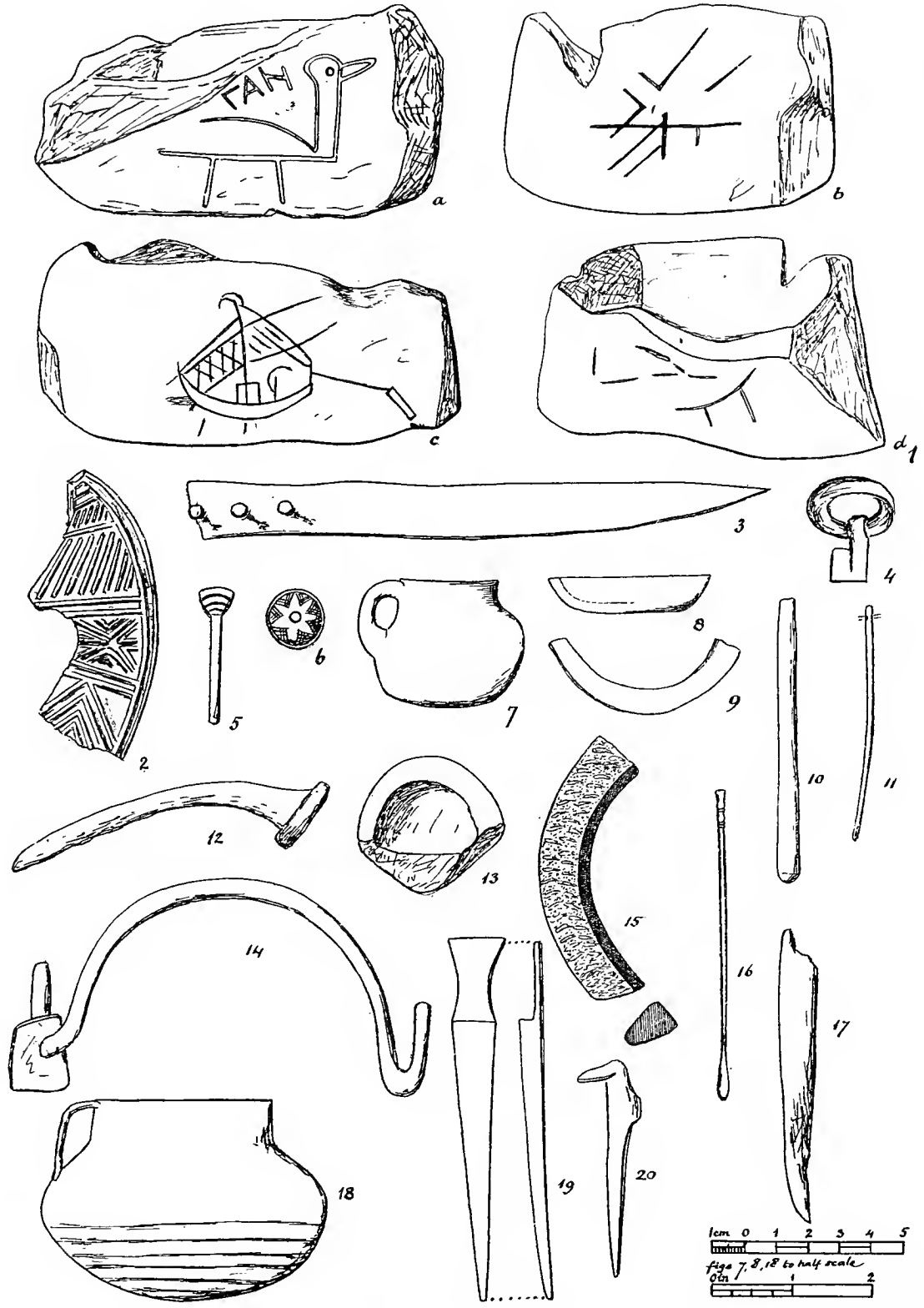

TOMB No. 185

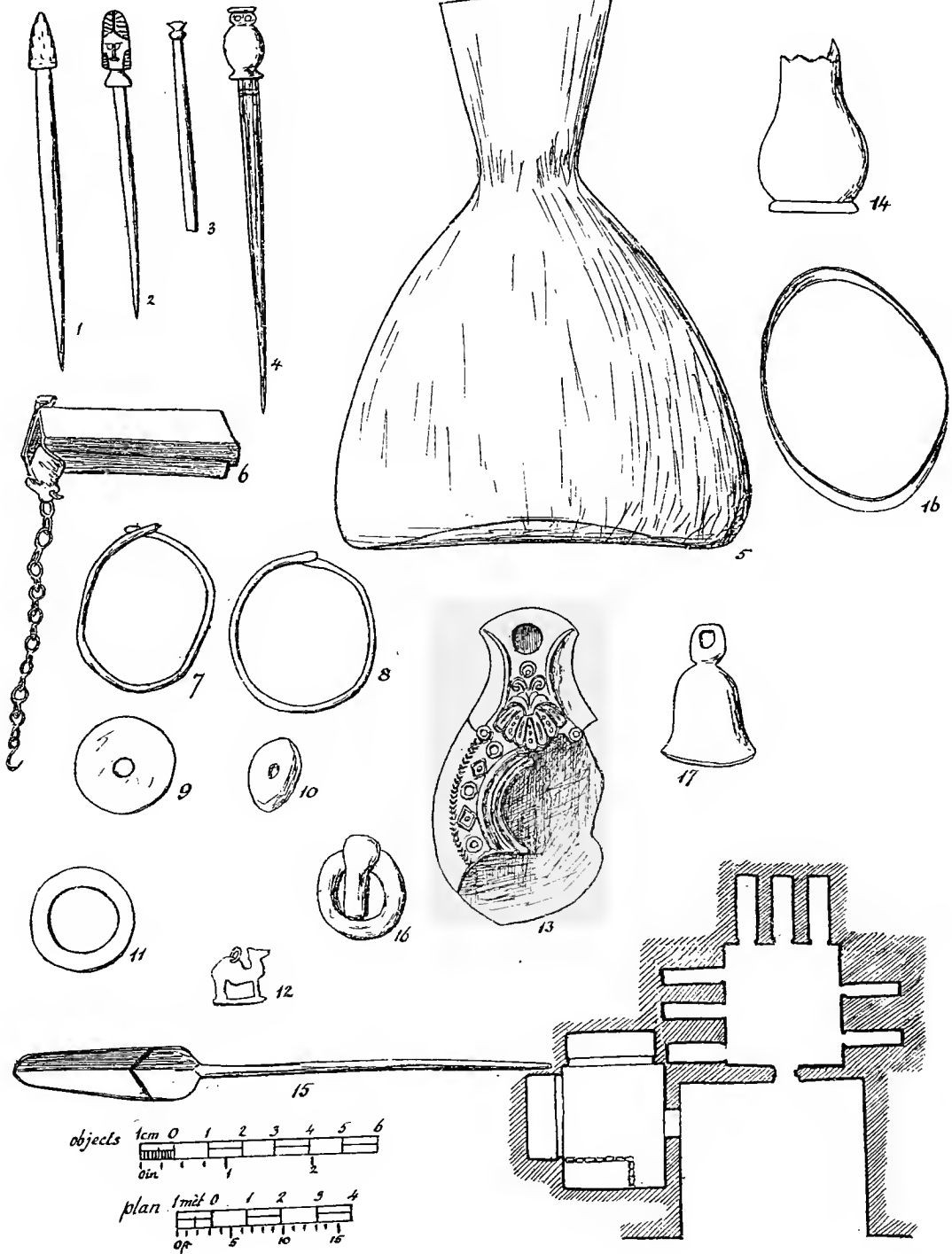





TOMB DEPOSITS

fig 4 is half scale

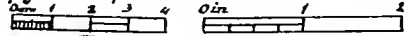

No. 189

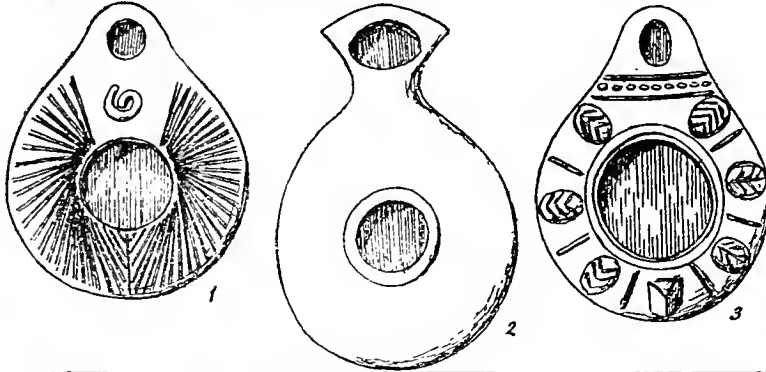

No. 168

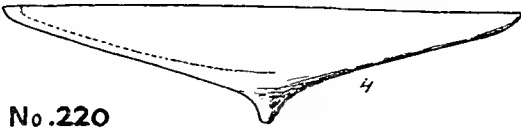
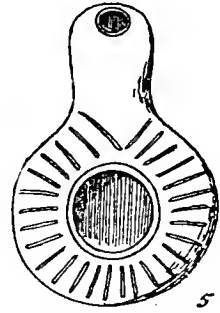

No. 220

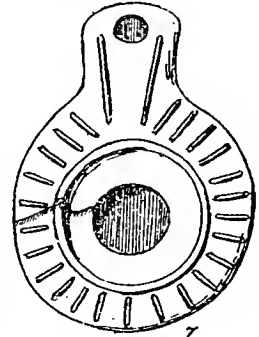
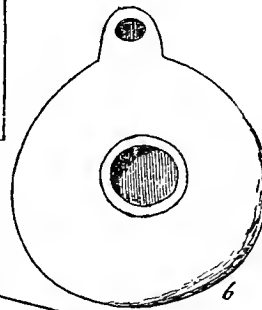

No. 159

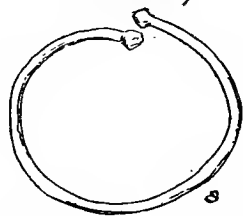
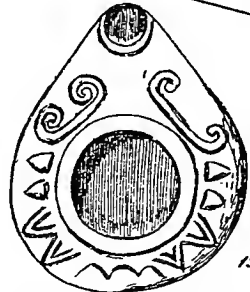
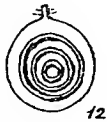
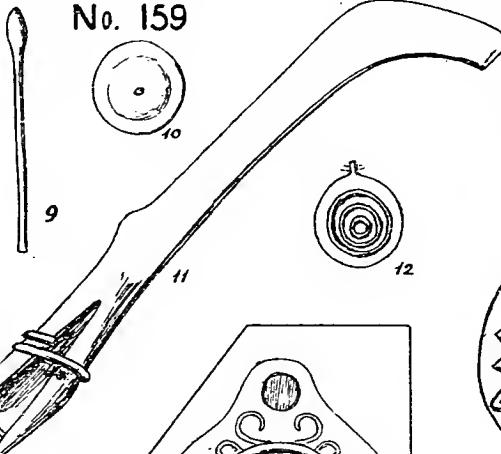

No. 154

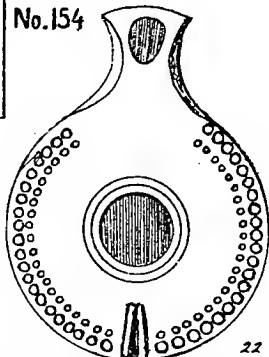

No. 10

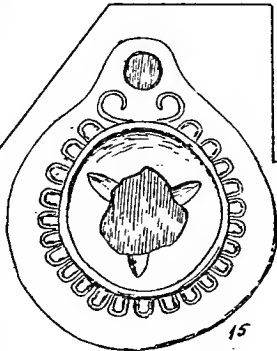

No. 33



No. 129

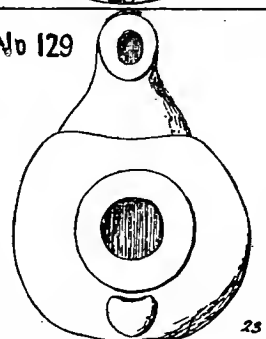

TOMB No. 193

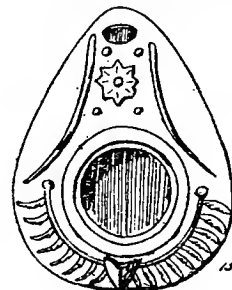
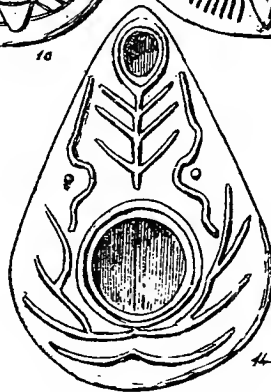
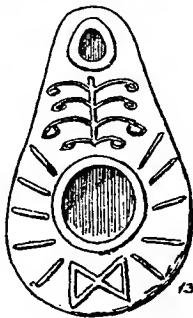
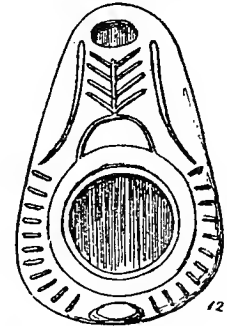
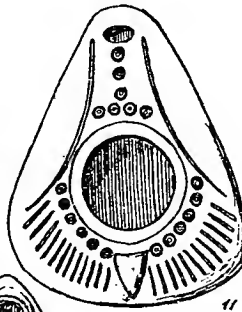
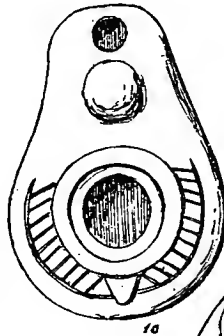
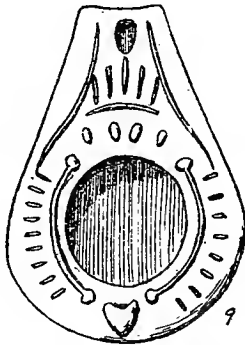
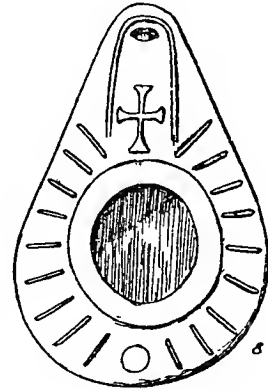
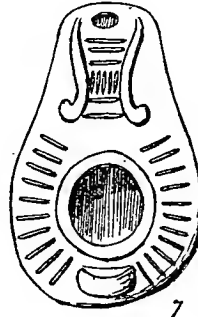
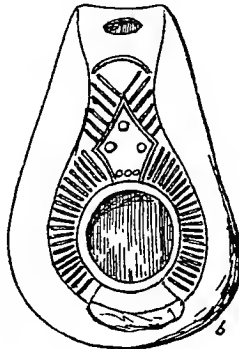
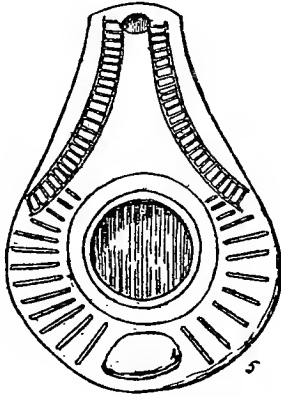
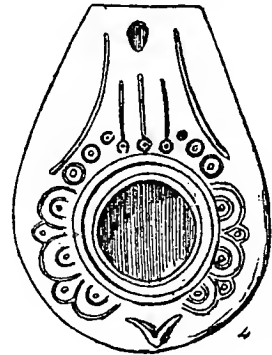
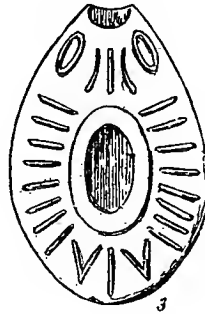
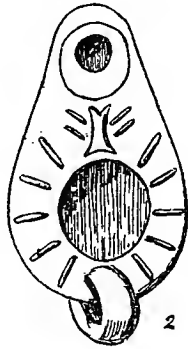
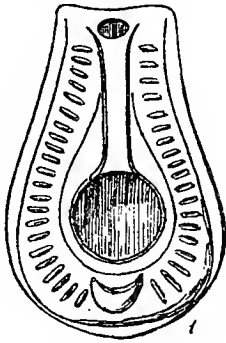
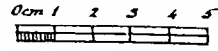
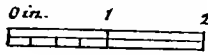







TOMB DEPOSITS

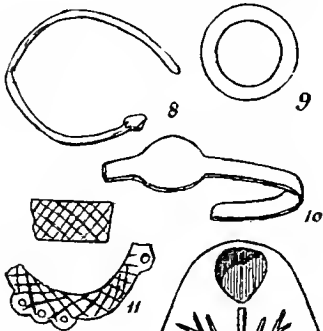
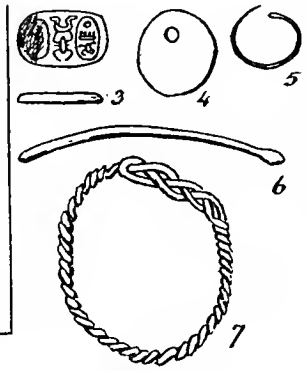
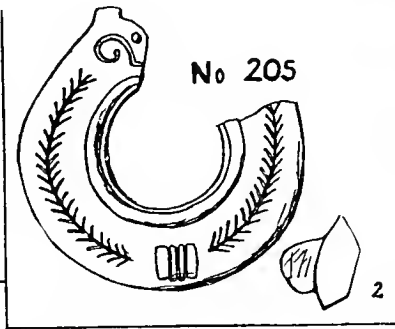
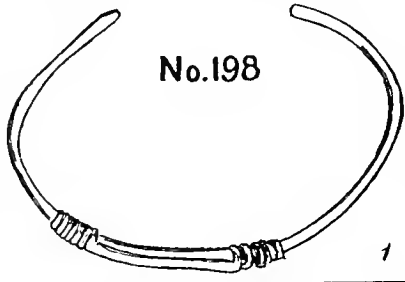

No. 196

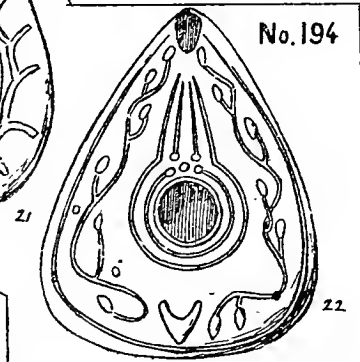
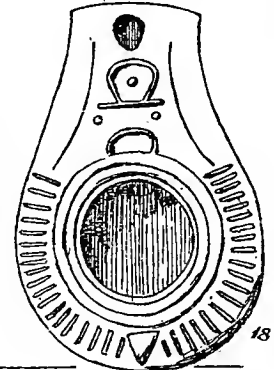
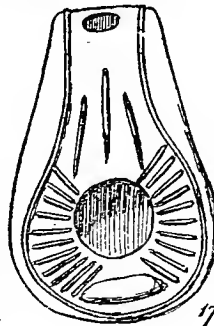
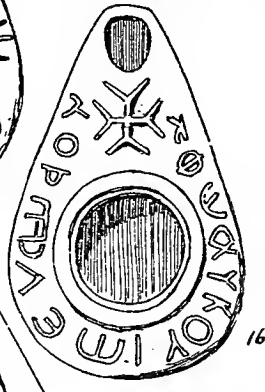
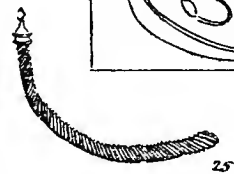
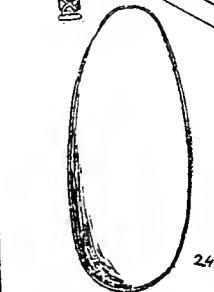
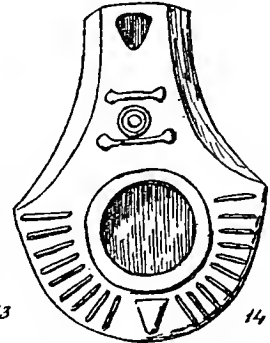
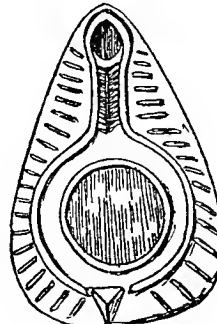
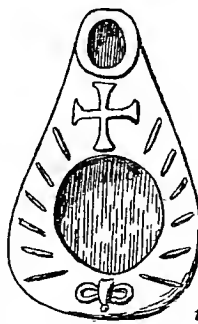
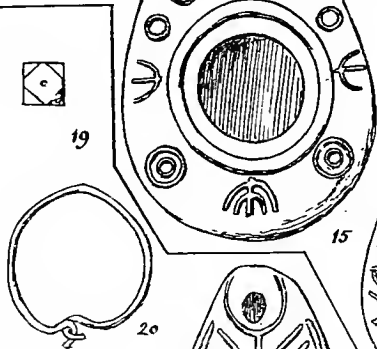

No. 194

No. 219

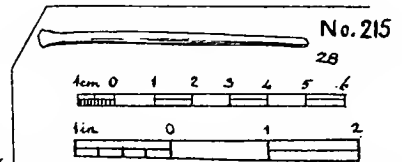
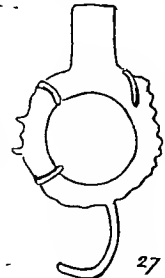
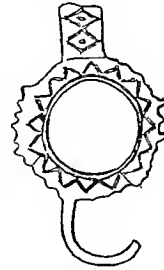

TOMB DEPOSITS

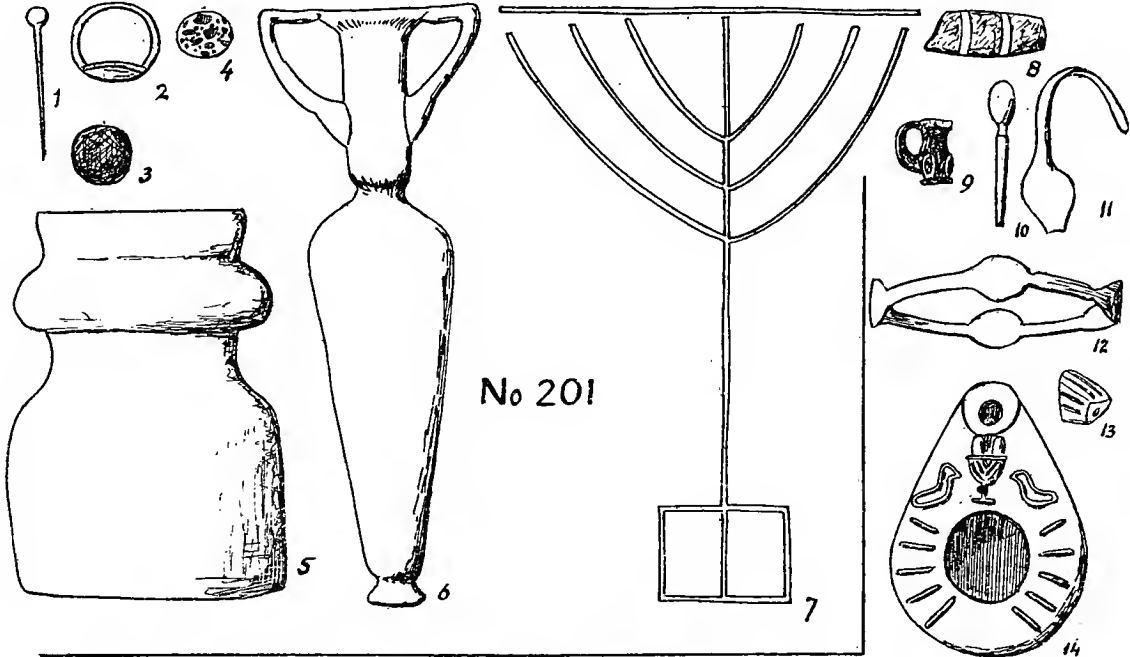

No 201

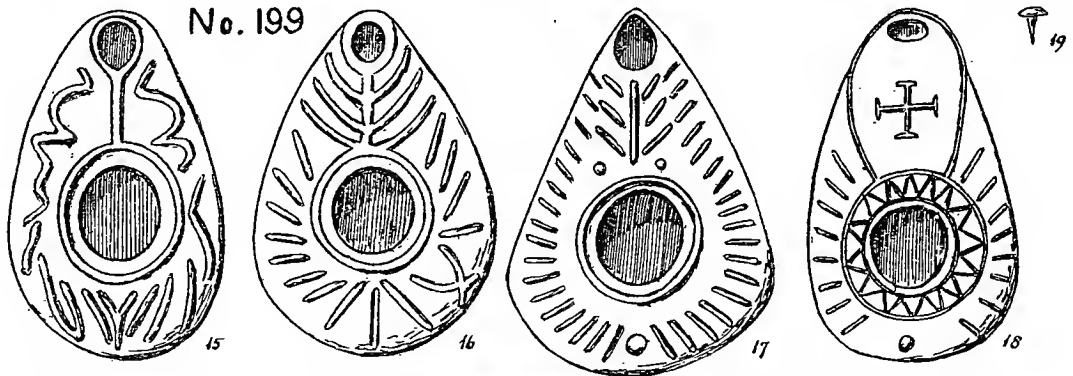

No. 199

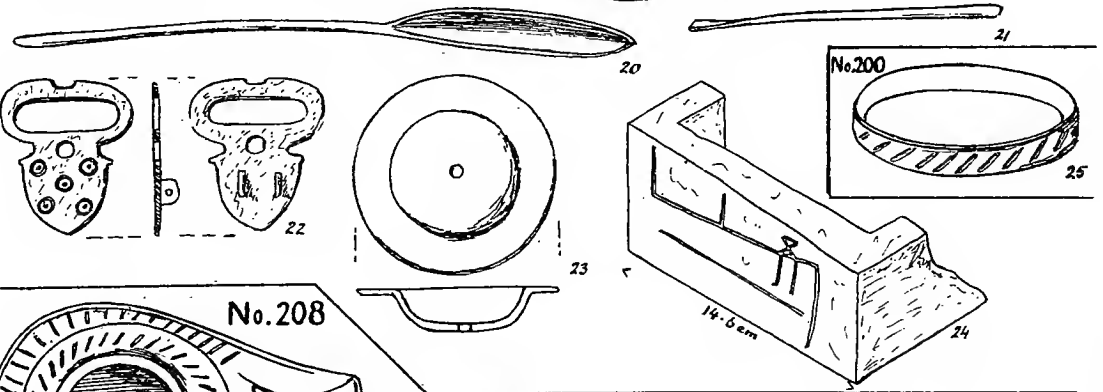

No. 200

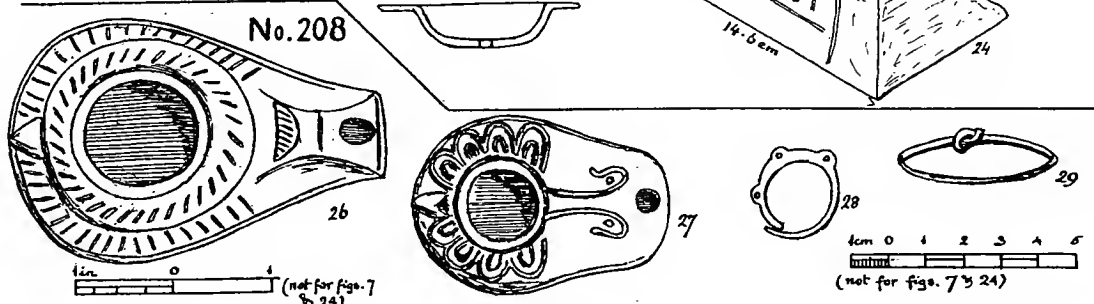

No. 208

lin. 0 4 (not for figs. 7 & 24)

cm 0 1 2 3 4 5 (not for figs. 7 & 24)





TOMB DEPOSITS

No. 226

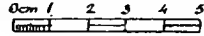
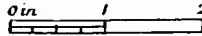
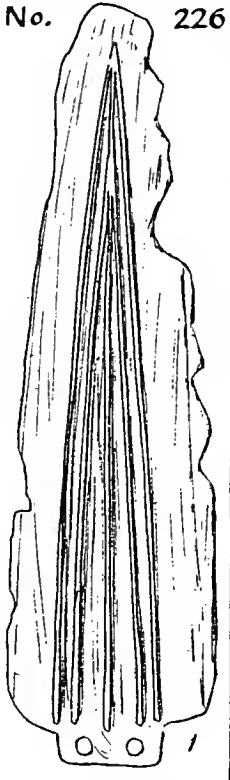

No. 224

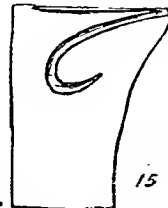
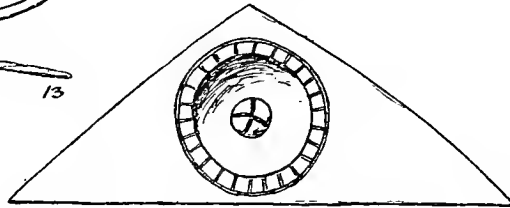
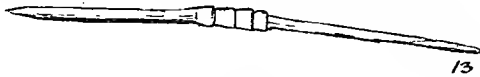
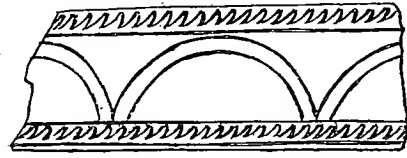
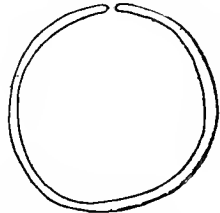
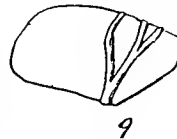
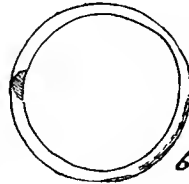
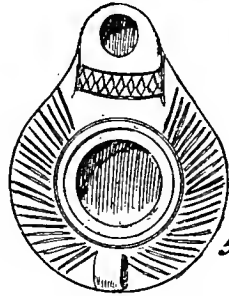
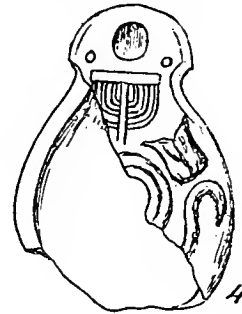
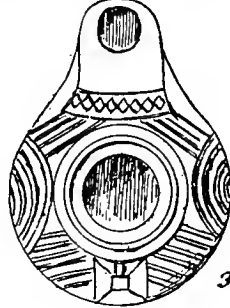

No. 125

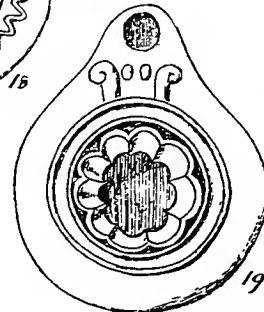
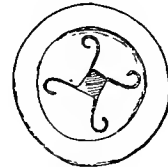
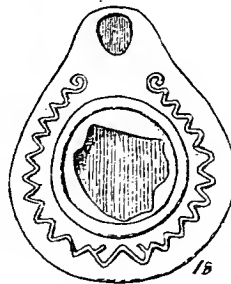
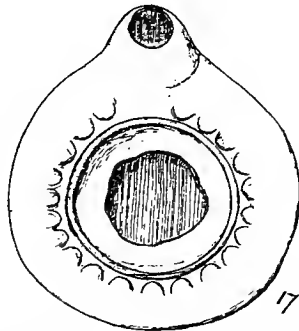

No. 223

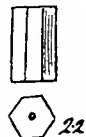
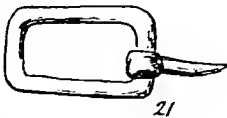
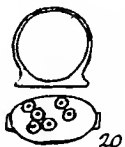

TOMB No. 252

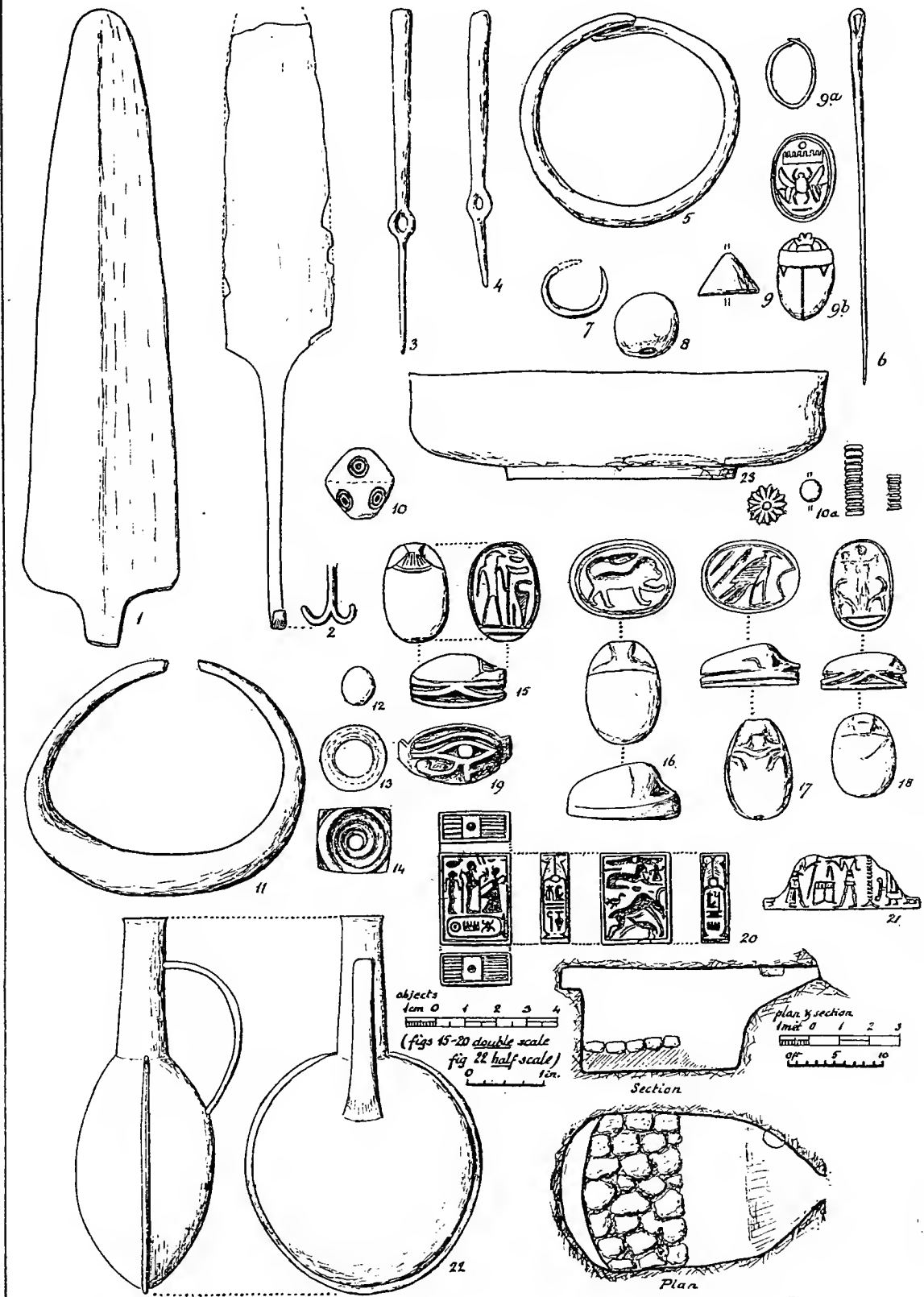







TOMB No. 252

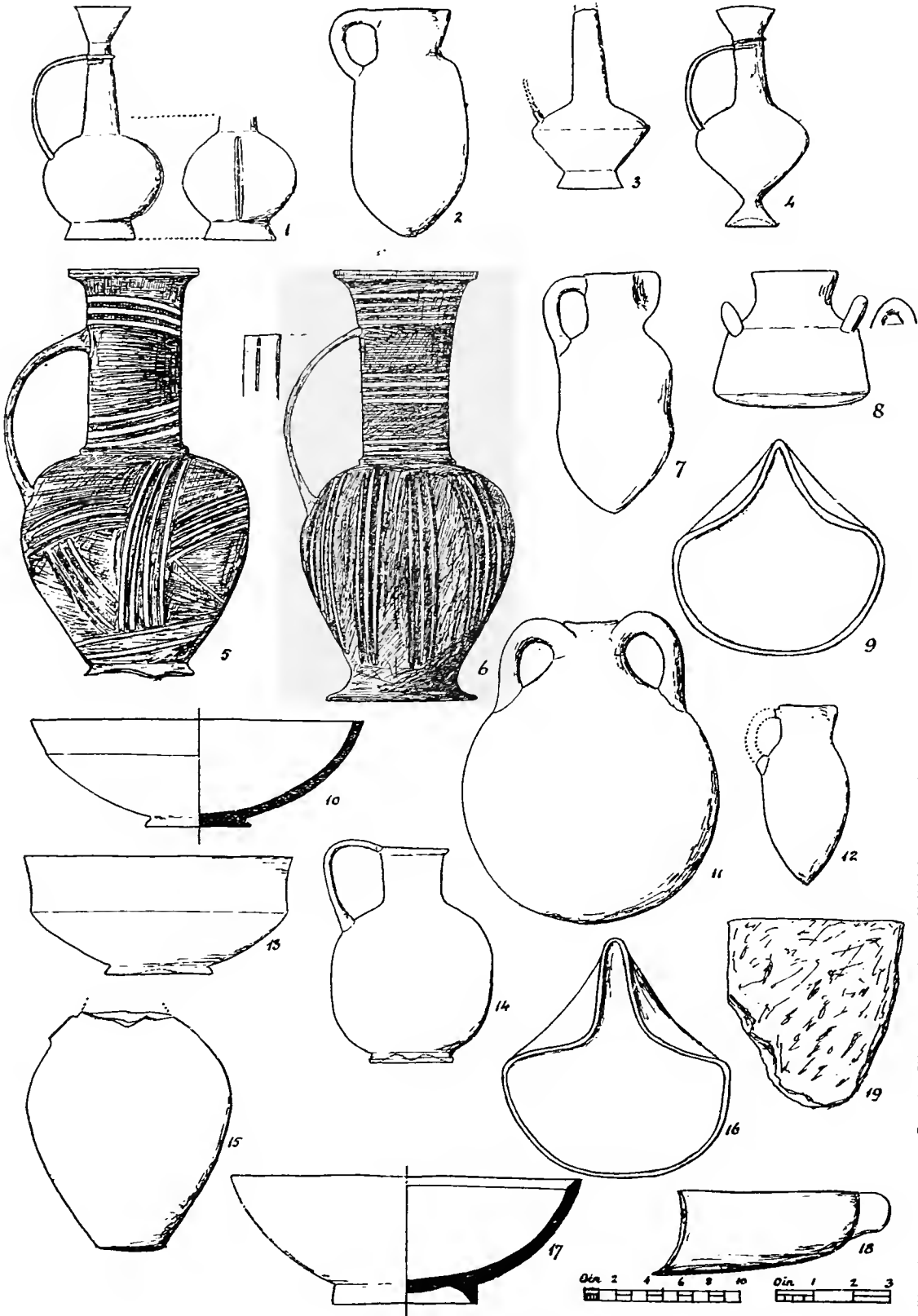

# GLASS VASES



1  
(tomb 201)



2  
(tomb 201)

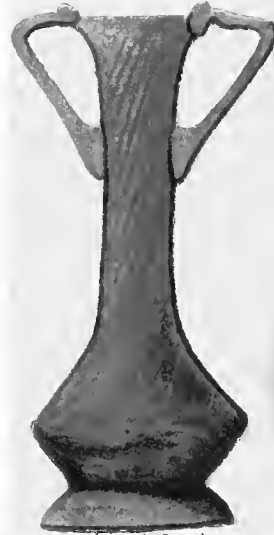

3 (tomb 205)



4 (tomb 155)



5  
(tomb 155)

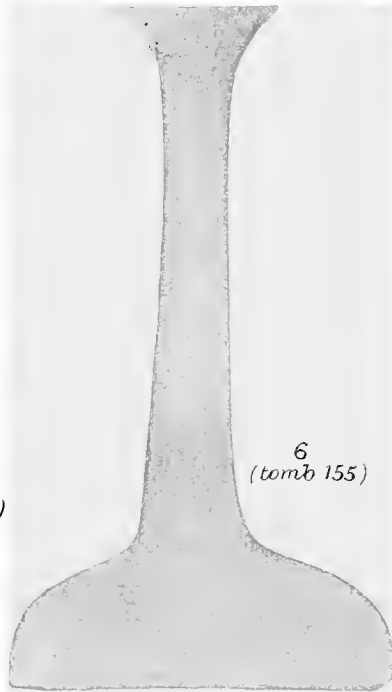

6  
(tomb 155)



7 (tomb 155)

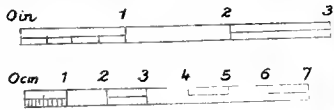





ANIMAL FIGURES - I.

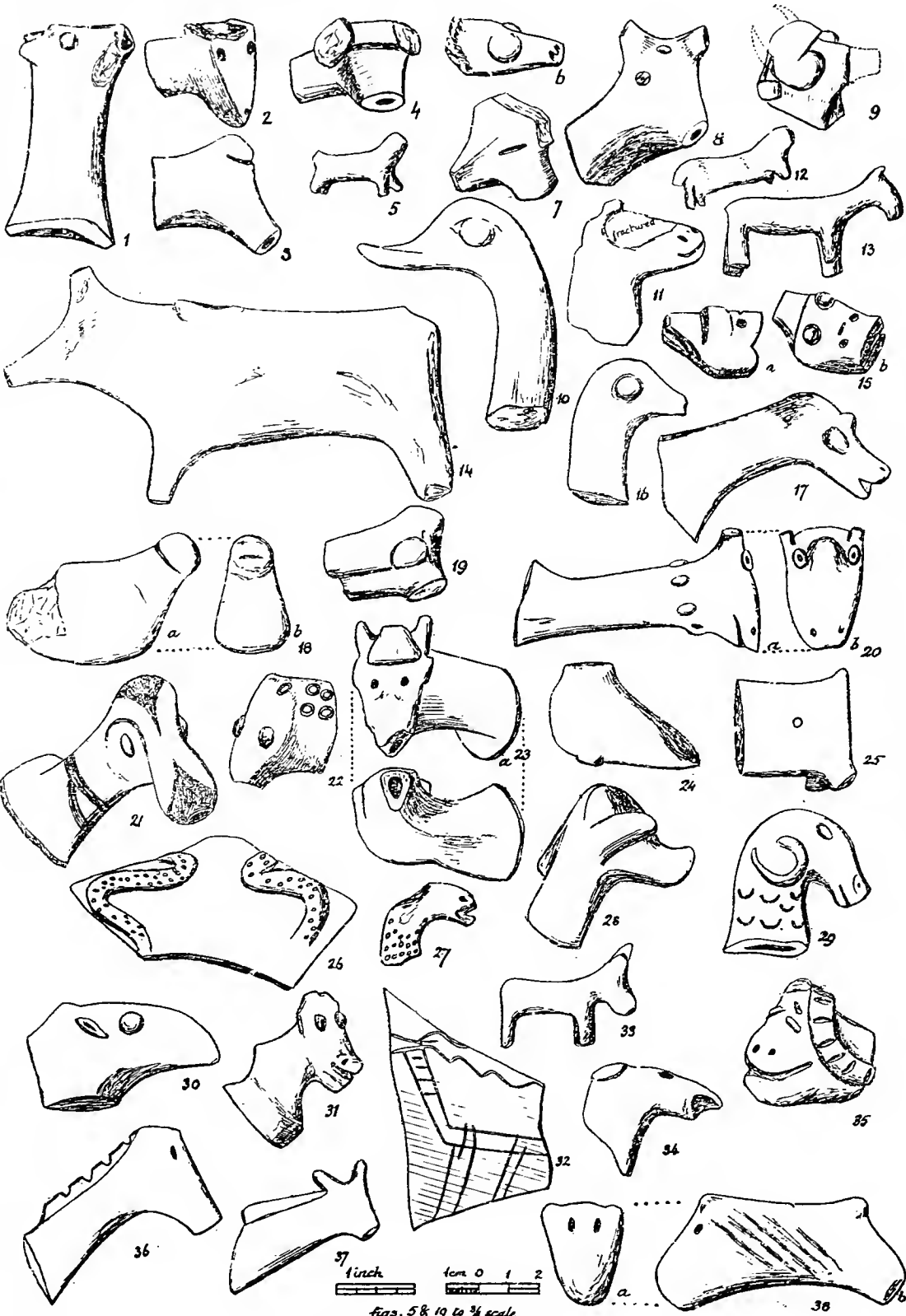

1 inch  
cm 0 1 2  
figs. 5 & 19 to 3/4 scale

ANIMAL FIGURES - II

cm 1 2 3 4 5  
cm 1 2 3 4 5

figs 16, 27 to 1/4 scale

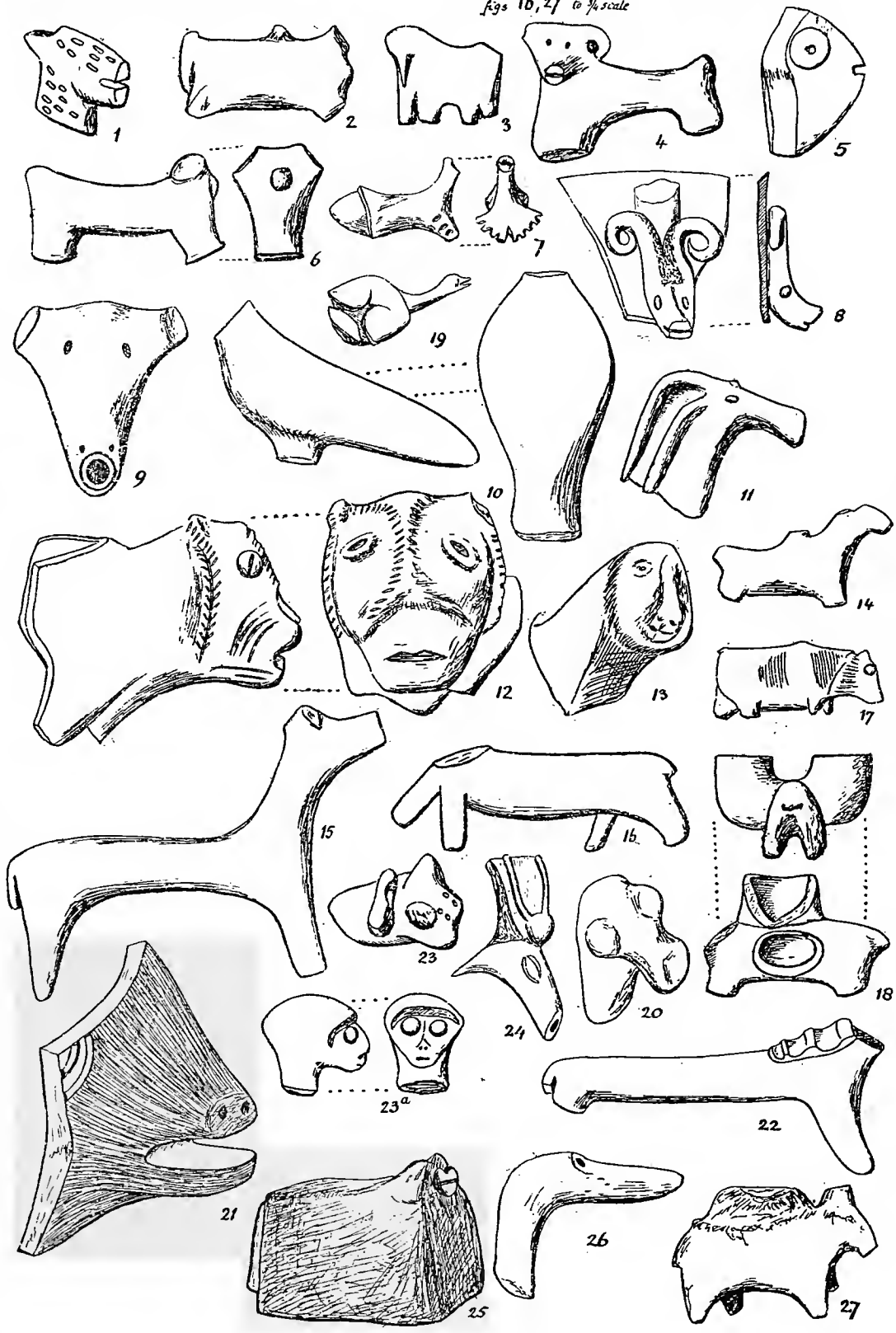



# ANIMAL FIGURES-III

0cm 1 2 0cm 1 2 3 4 5

fig. 6 to 14 and fig. 23 to 1/2 scale

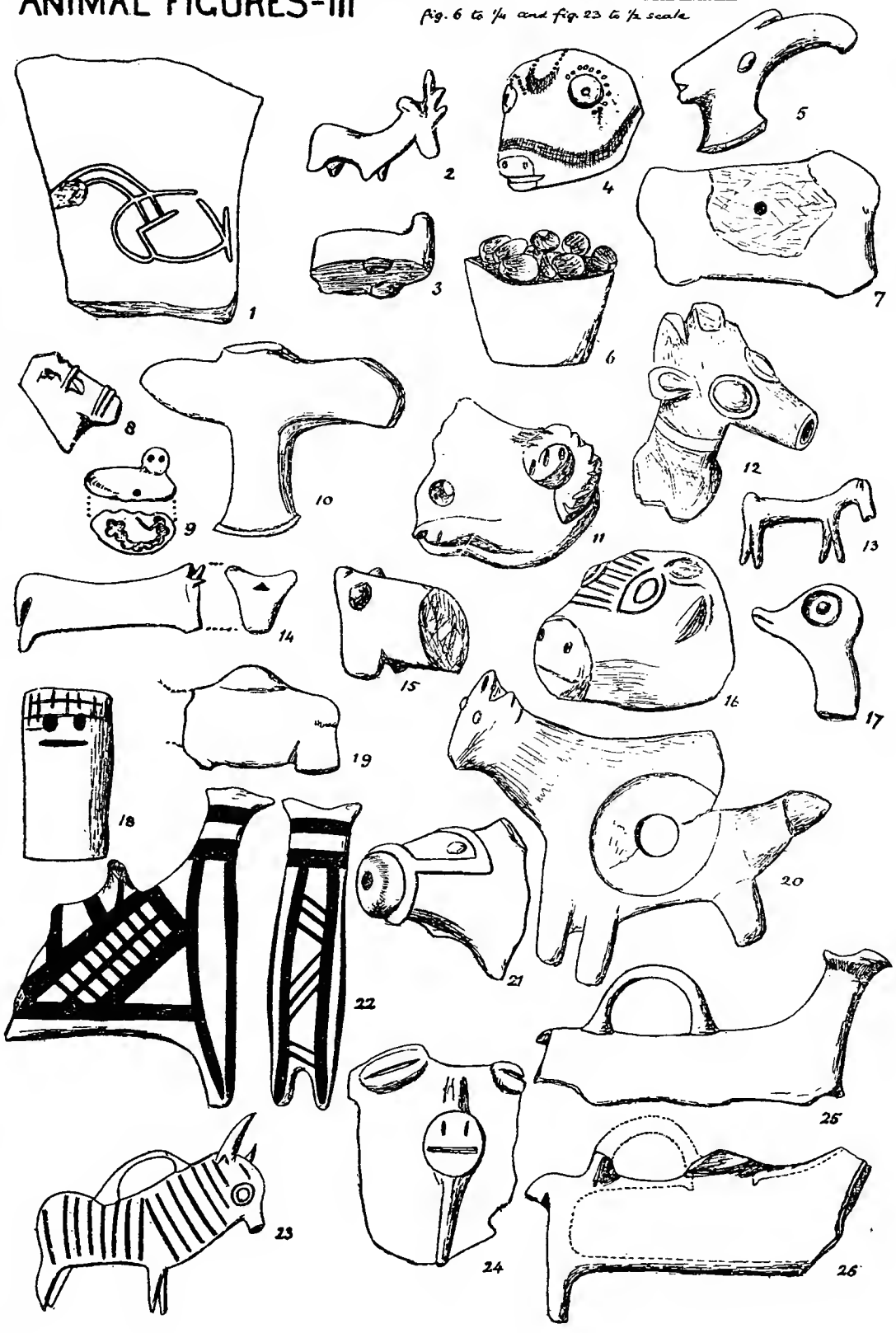







FIG. 1

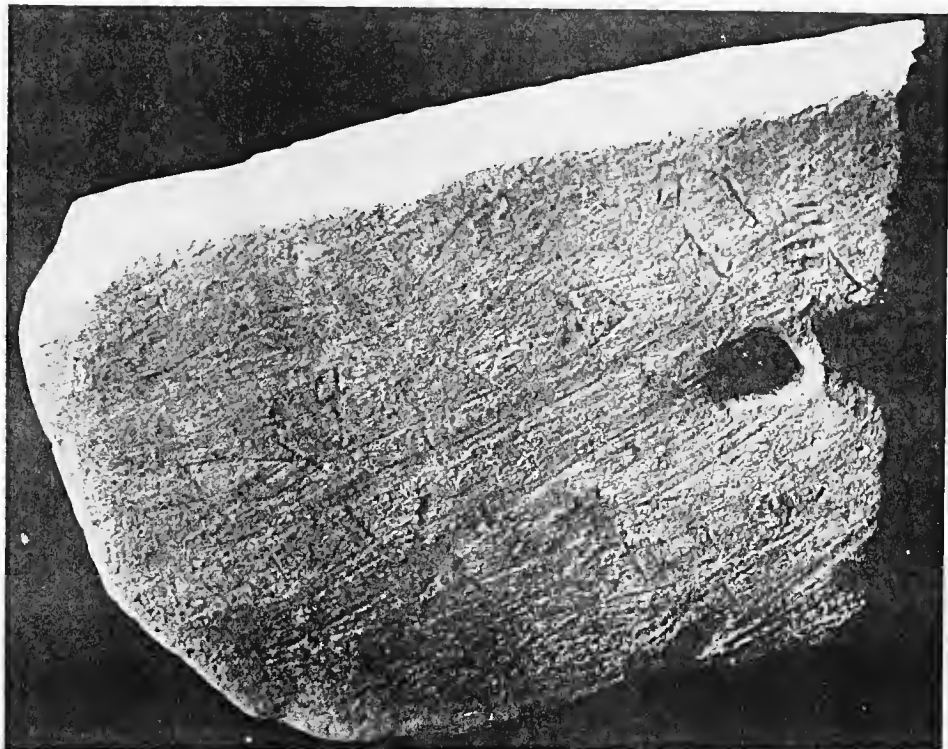

FIG. 2





# AGRICULTURAL IMPLEMENTS

1 cm 0 1 2 3 4

1 in 0 1 2

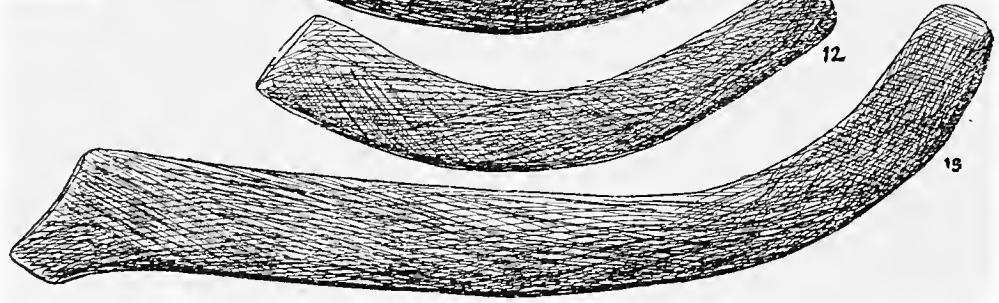
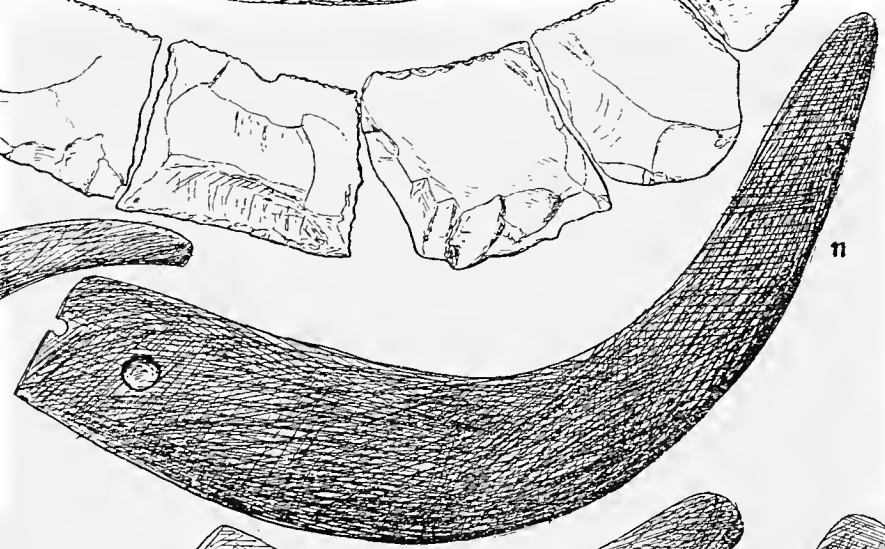
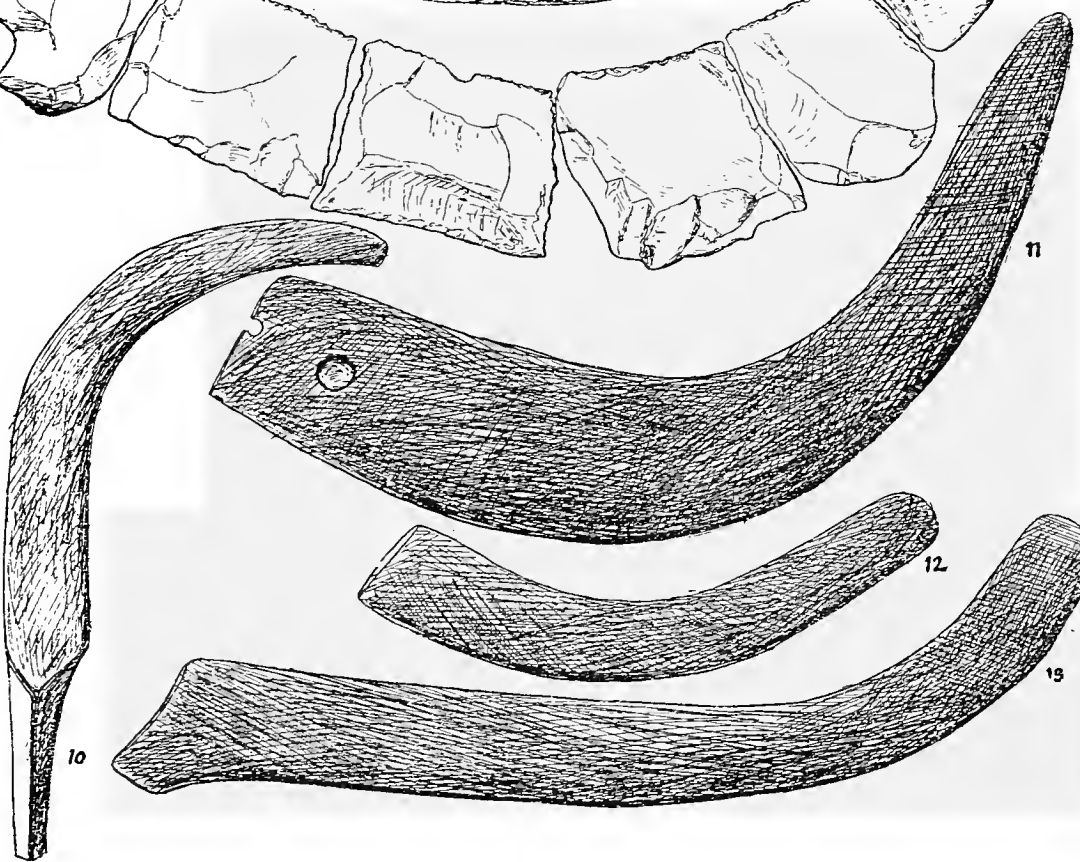
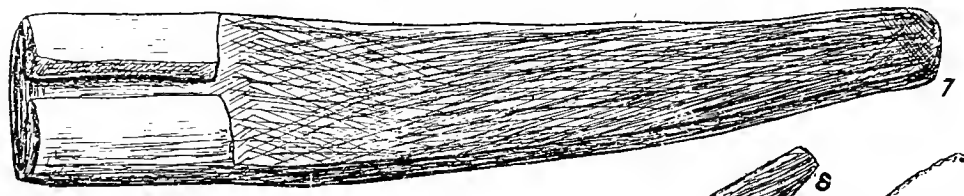
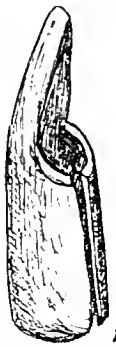

# OLIVE-PRESSES

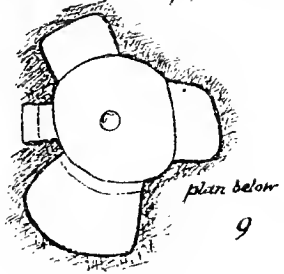
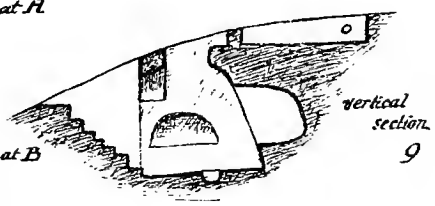
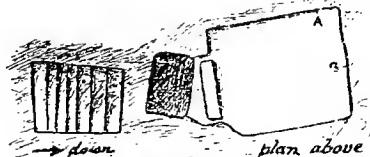
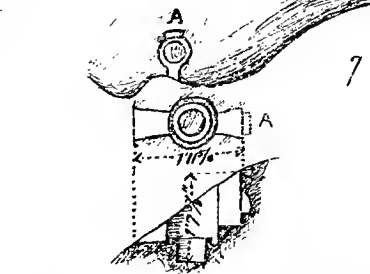
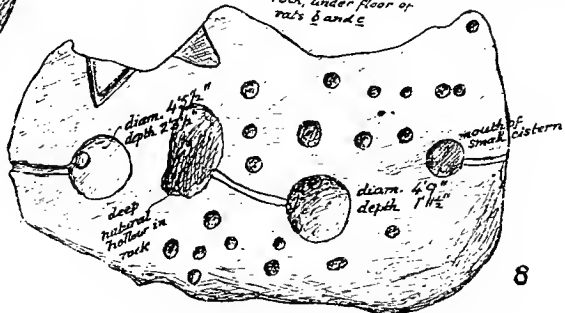
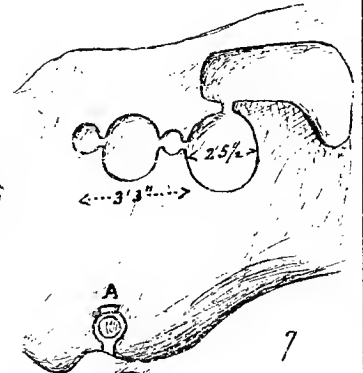
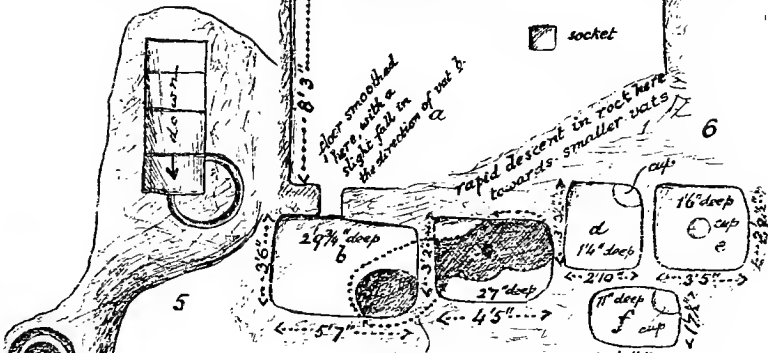
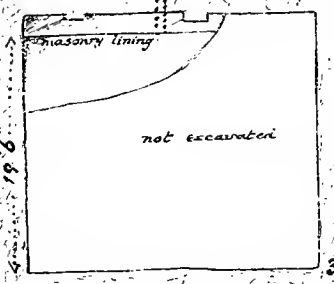
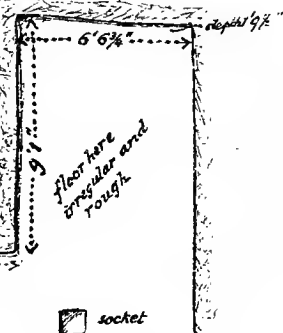
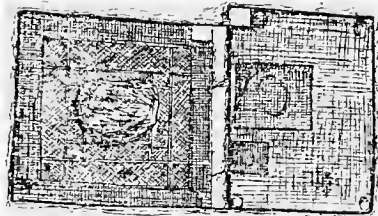
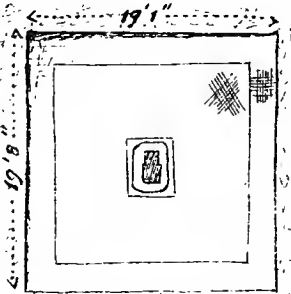
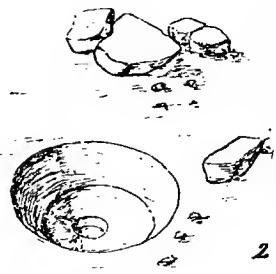
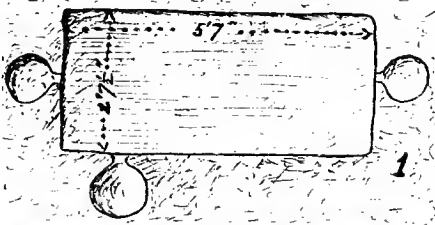

max. dimensions of rock surface, 37'3" x 18'10"

9

9

9



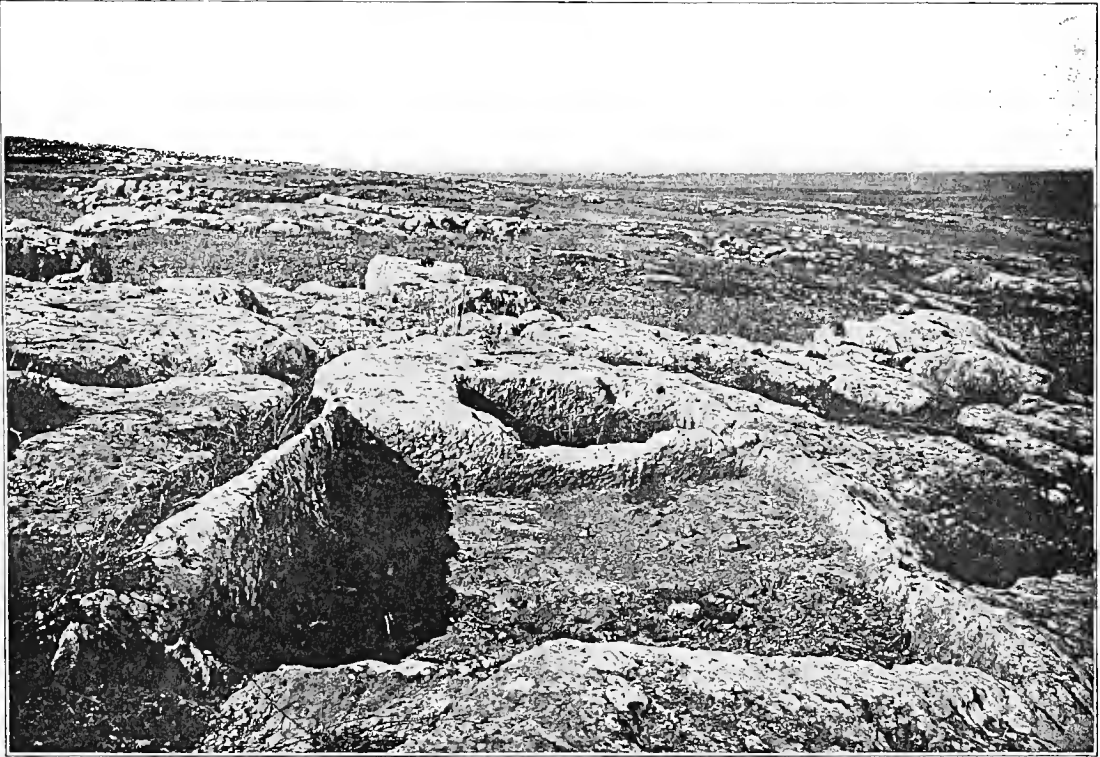

OLIVE-PRESSES OF NORMAL TYPE







# OLIVE-PRESS f ARD 'AIN EL-BUTMEH

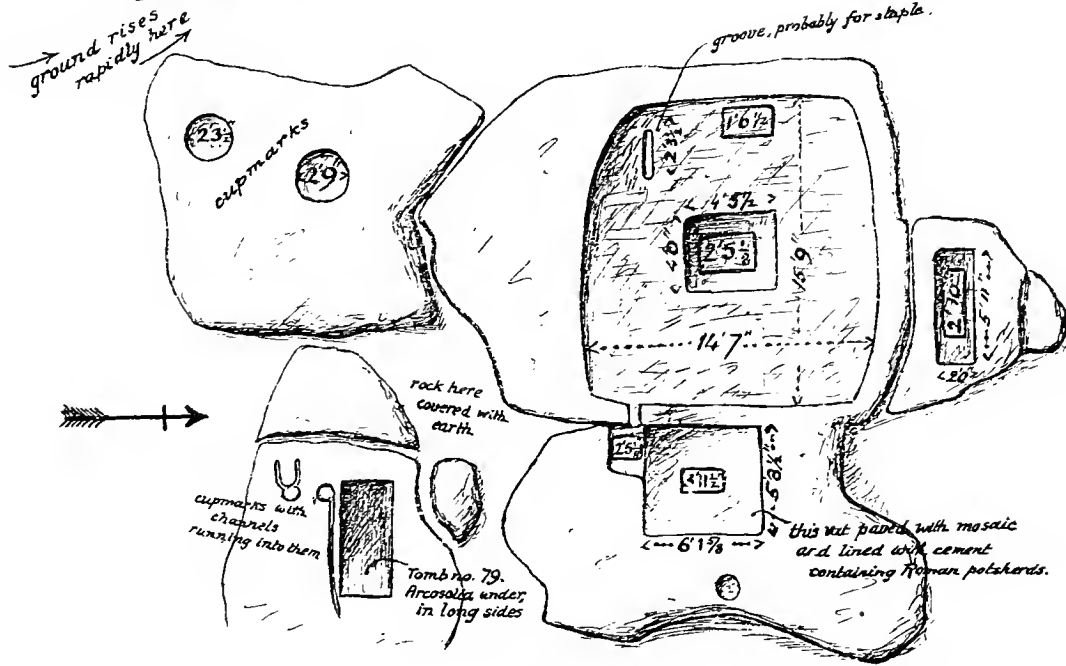
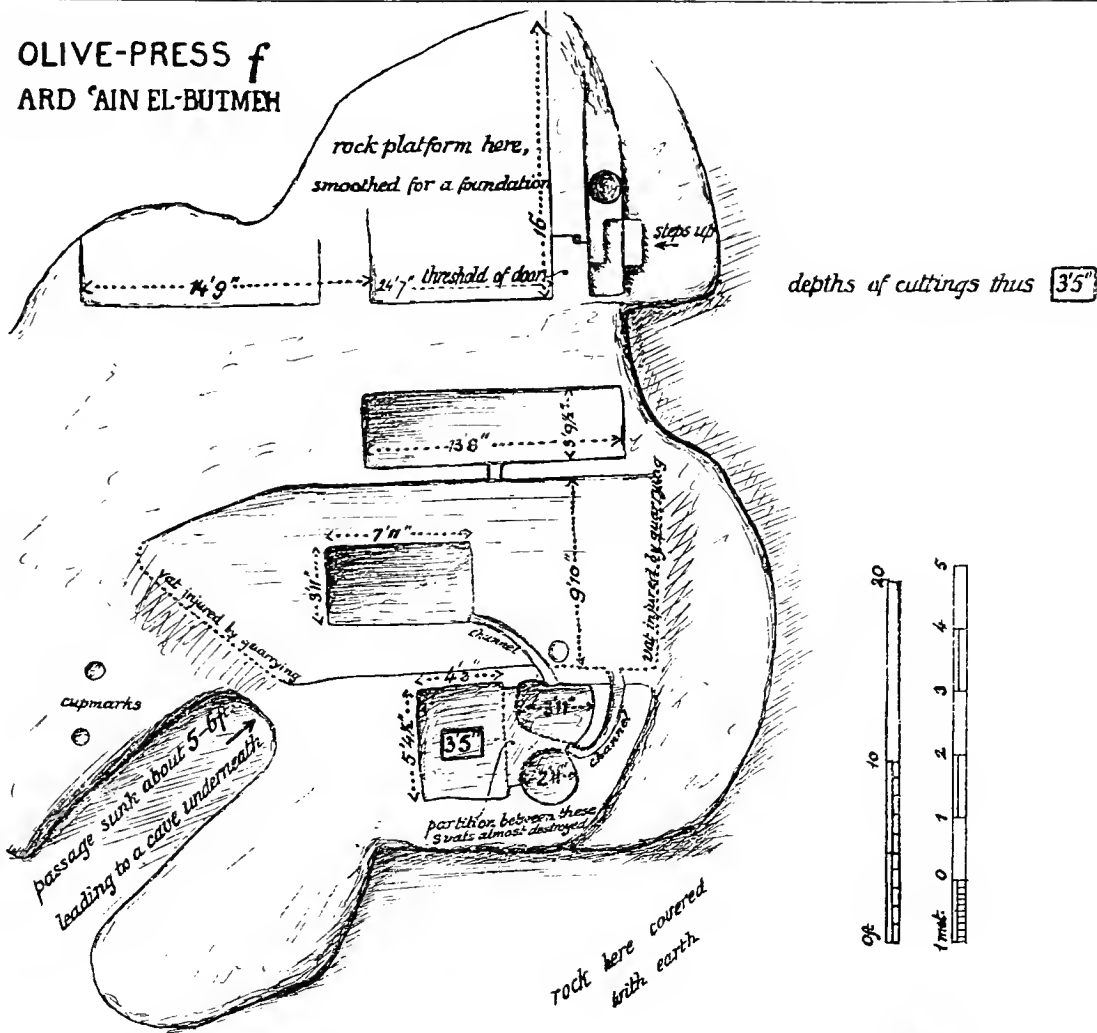

# SPINDLE-WHORLS AND BUTTONS

1 in.

0 cm. 1 2

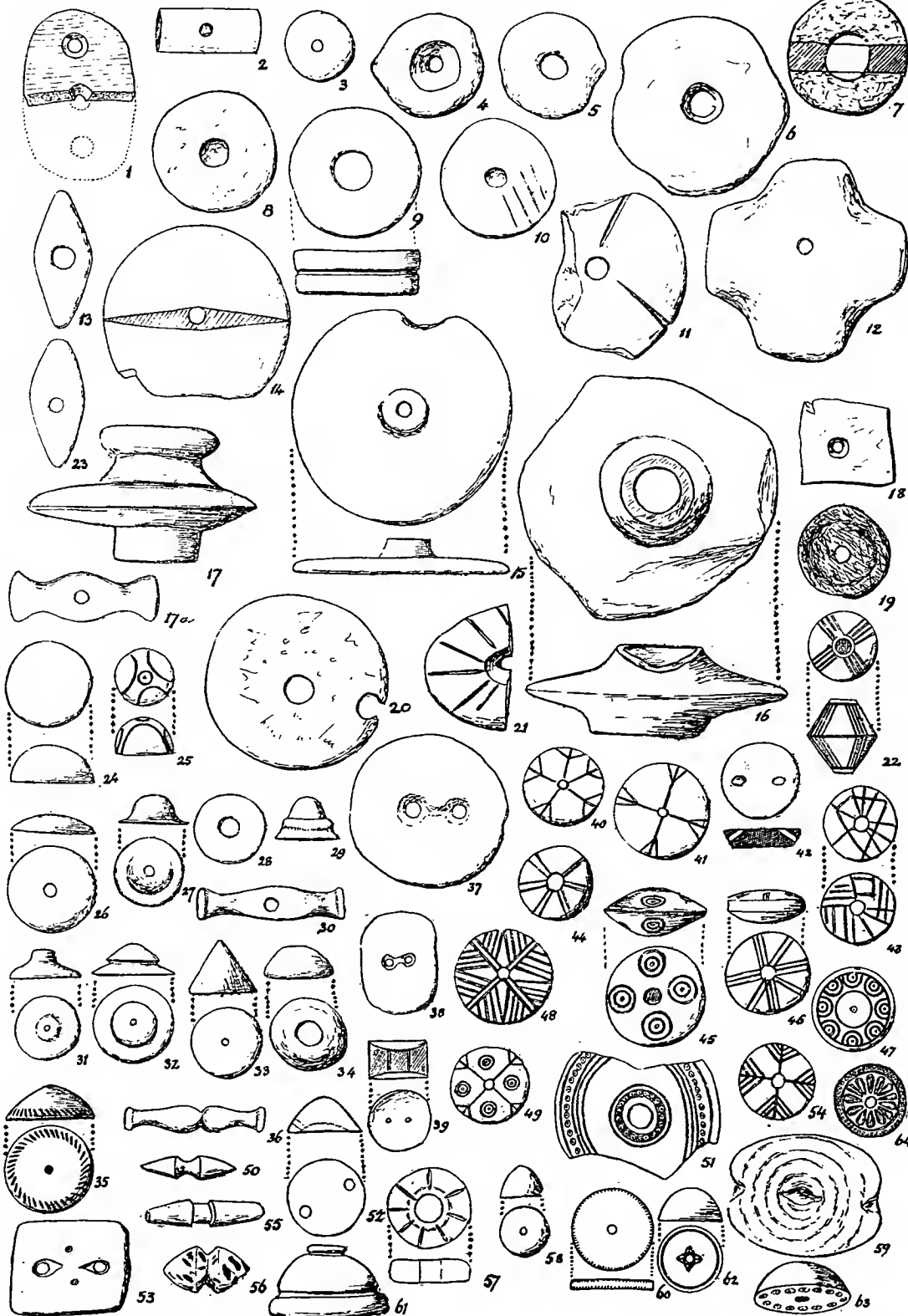





# BRONZE PINS AND NEEDLES

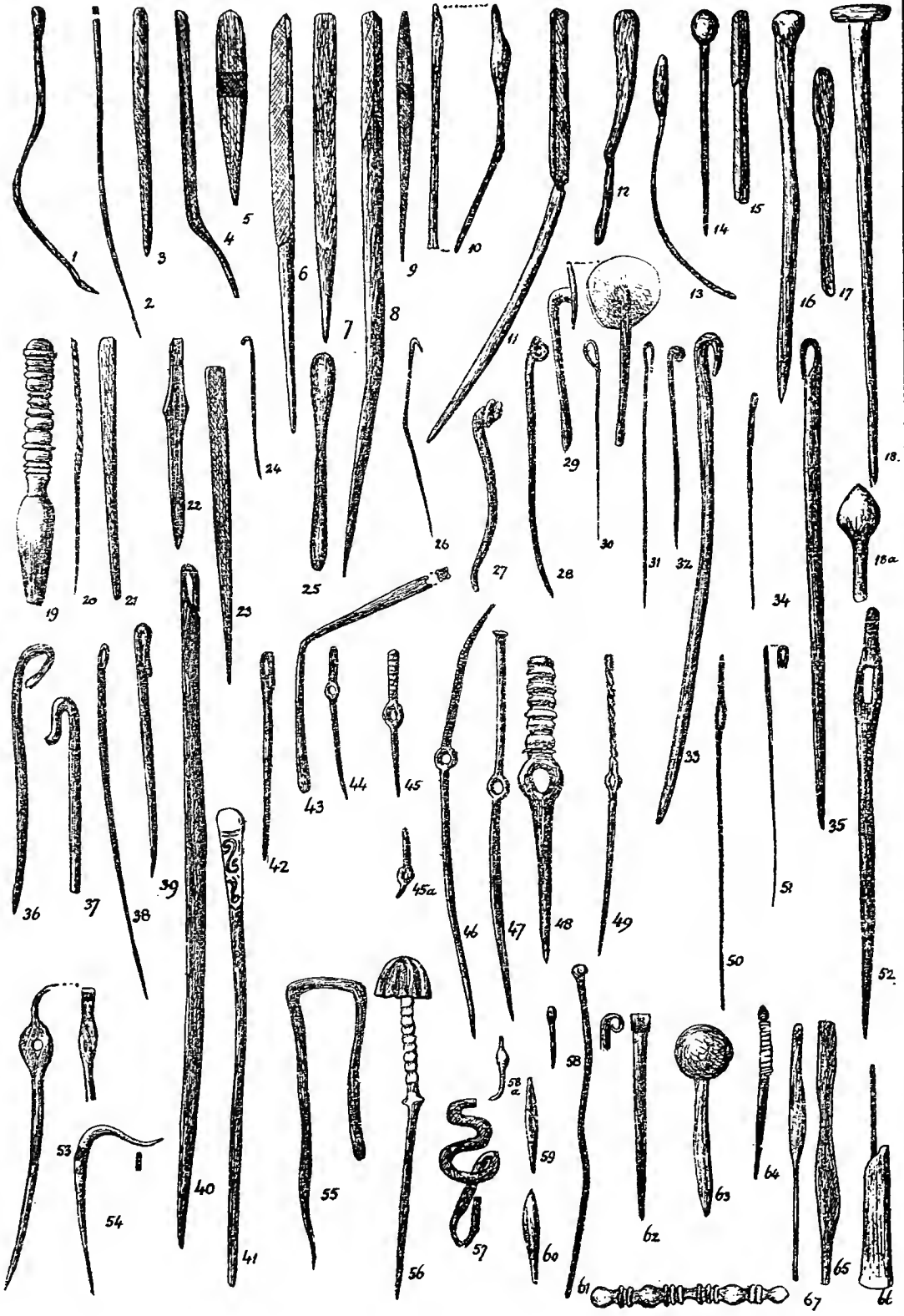
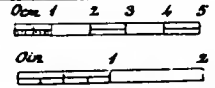

FIBULÆ &c

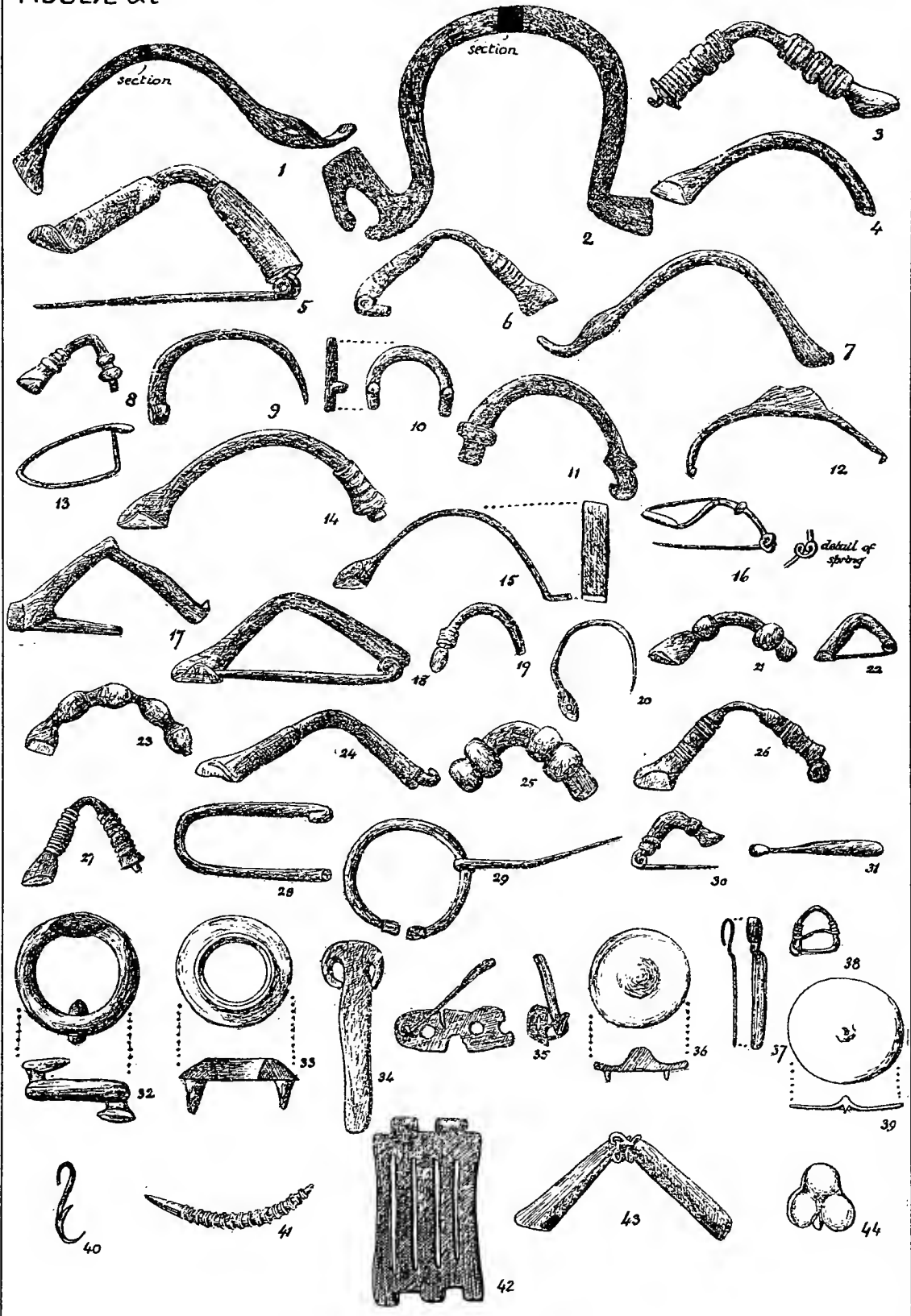
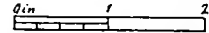
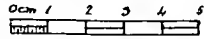







BRONZE ORNAMENTS &c

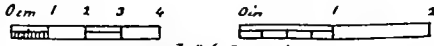
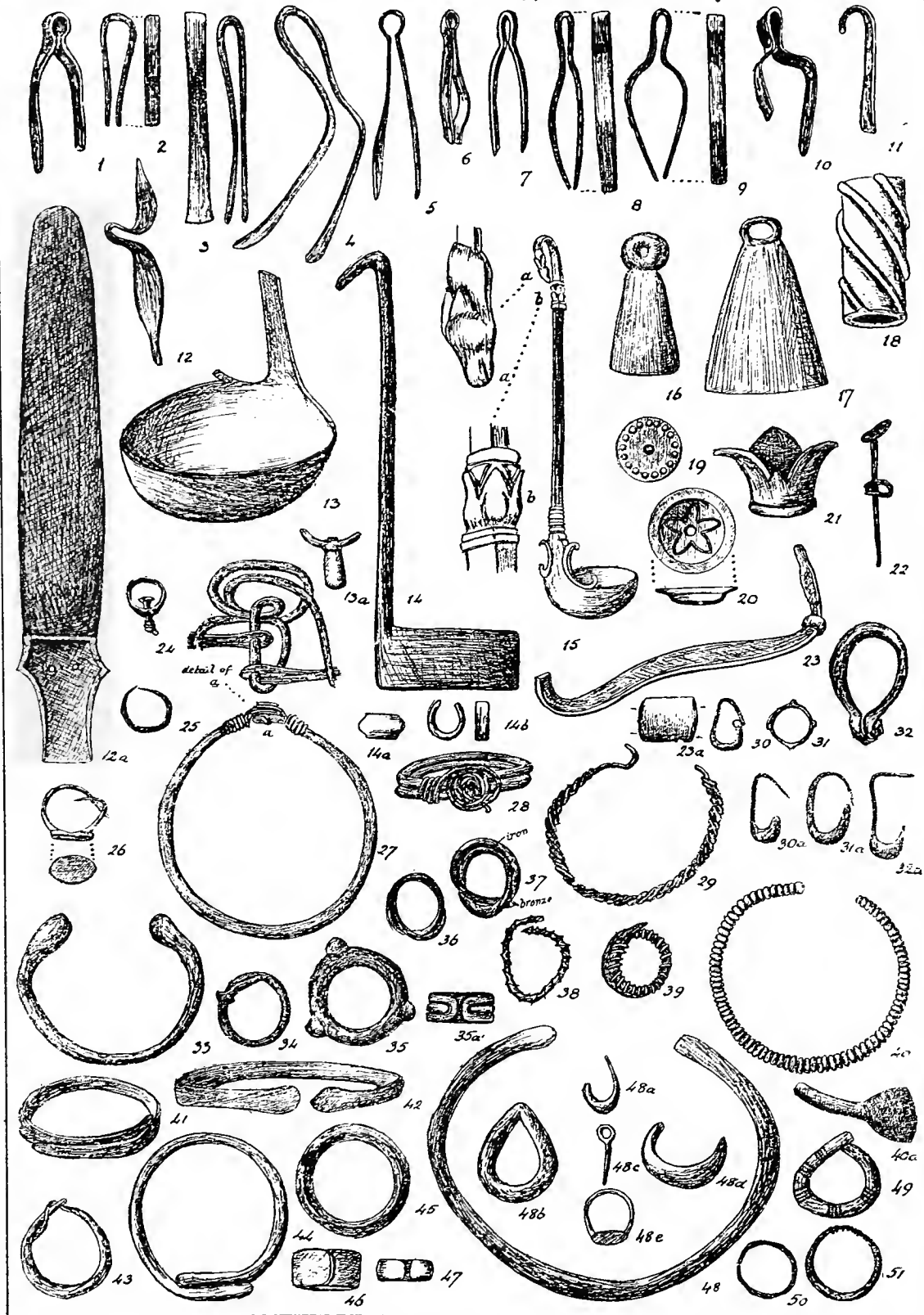
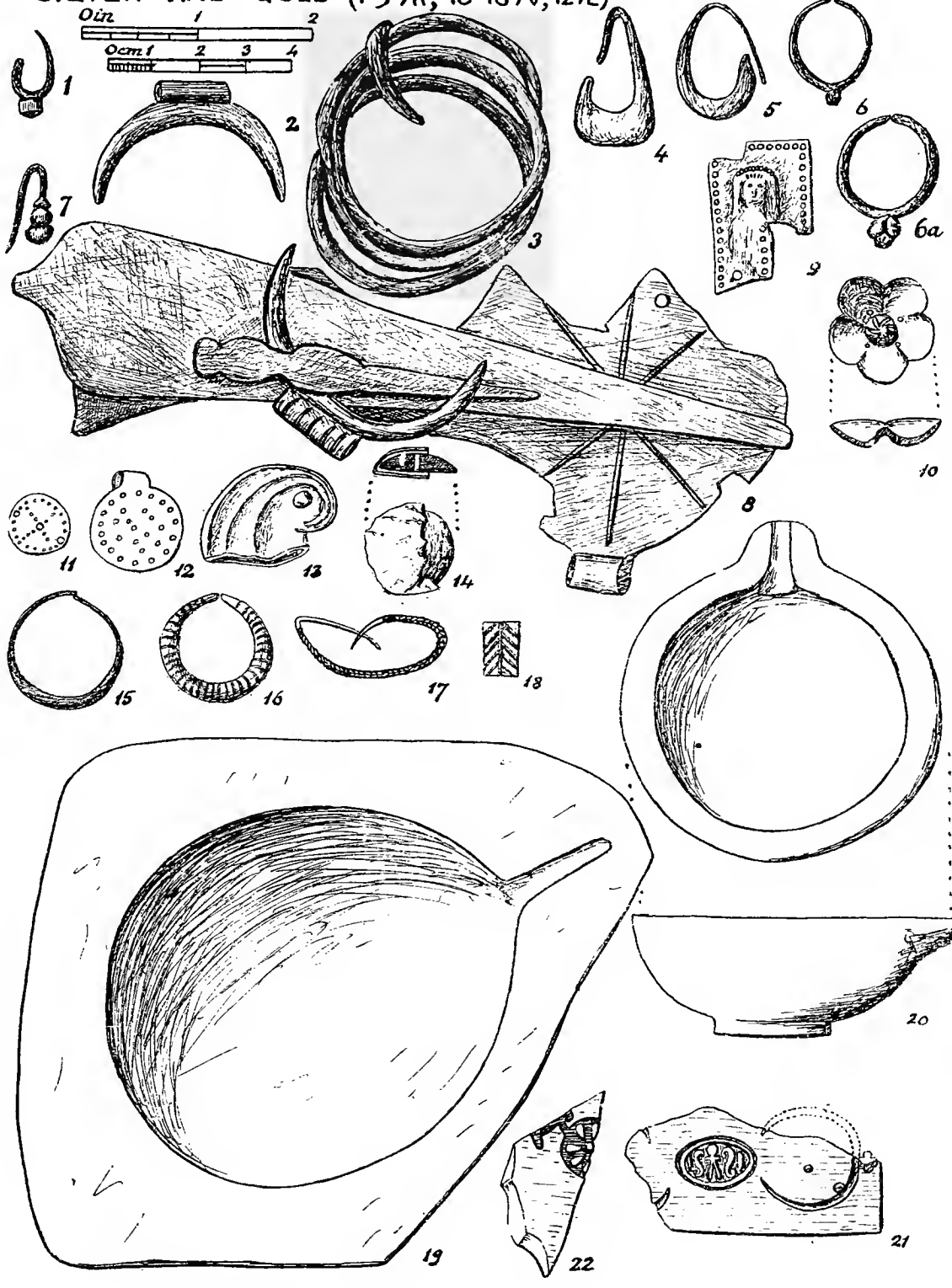
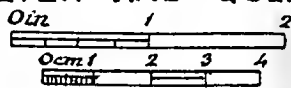

Fig. 45 is  $9\frac{1}{8}$ " (25cm.) long



SILVER AND GOLD (1-9 A, 10-18 A, 12 E)







# BEADS

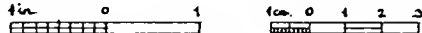

figs. a48, a49, to double scale

(a)

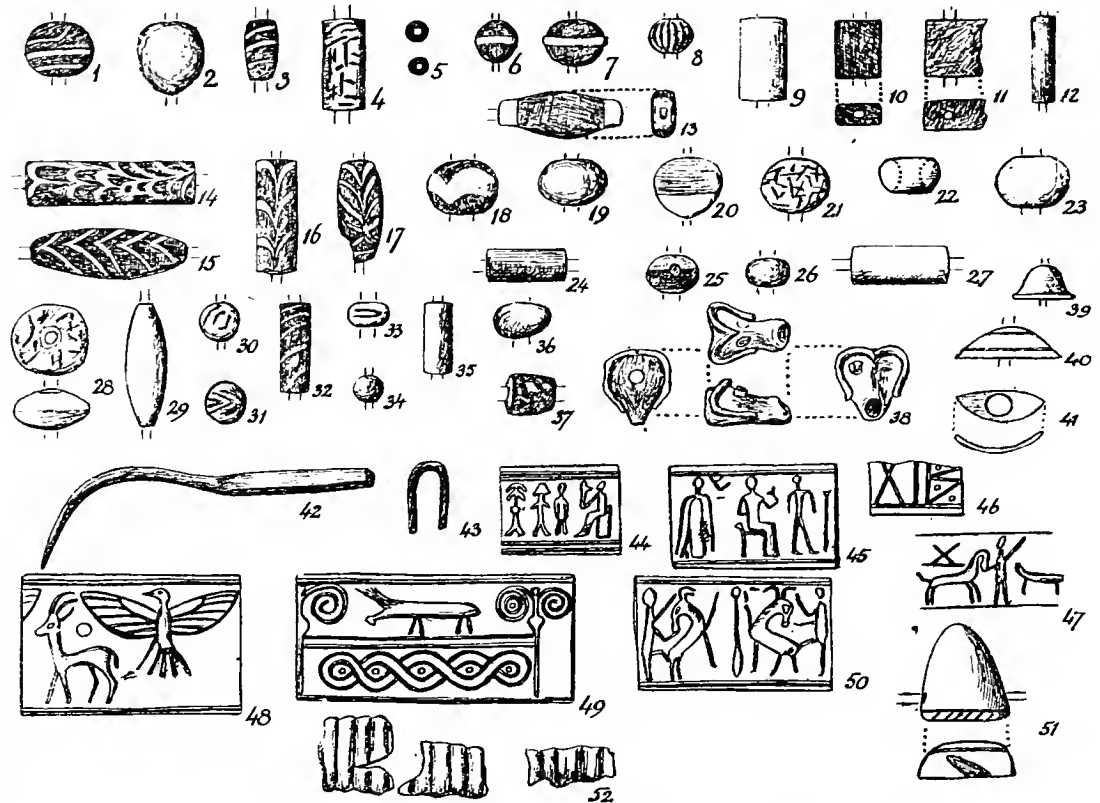

(b)

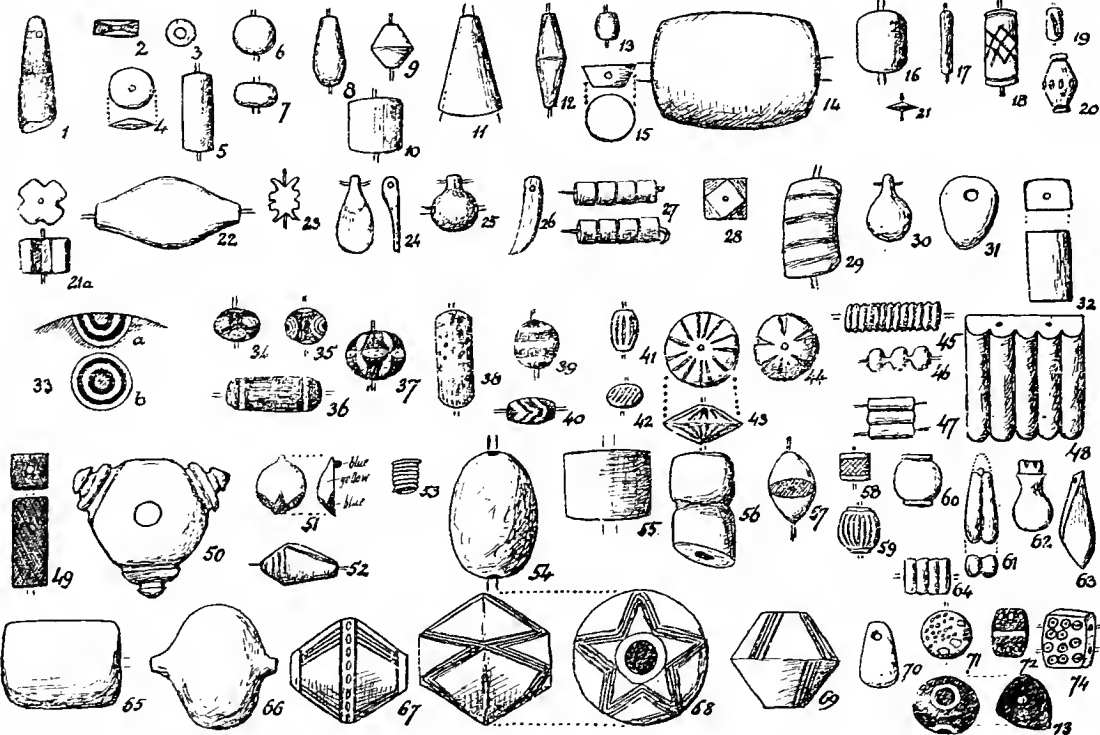

# FLINT IMPLEMENTS

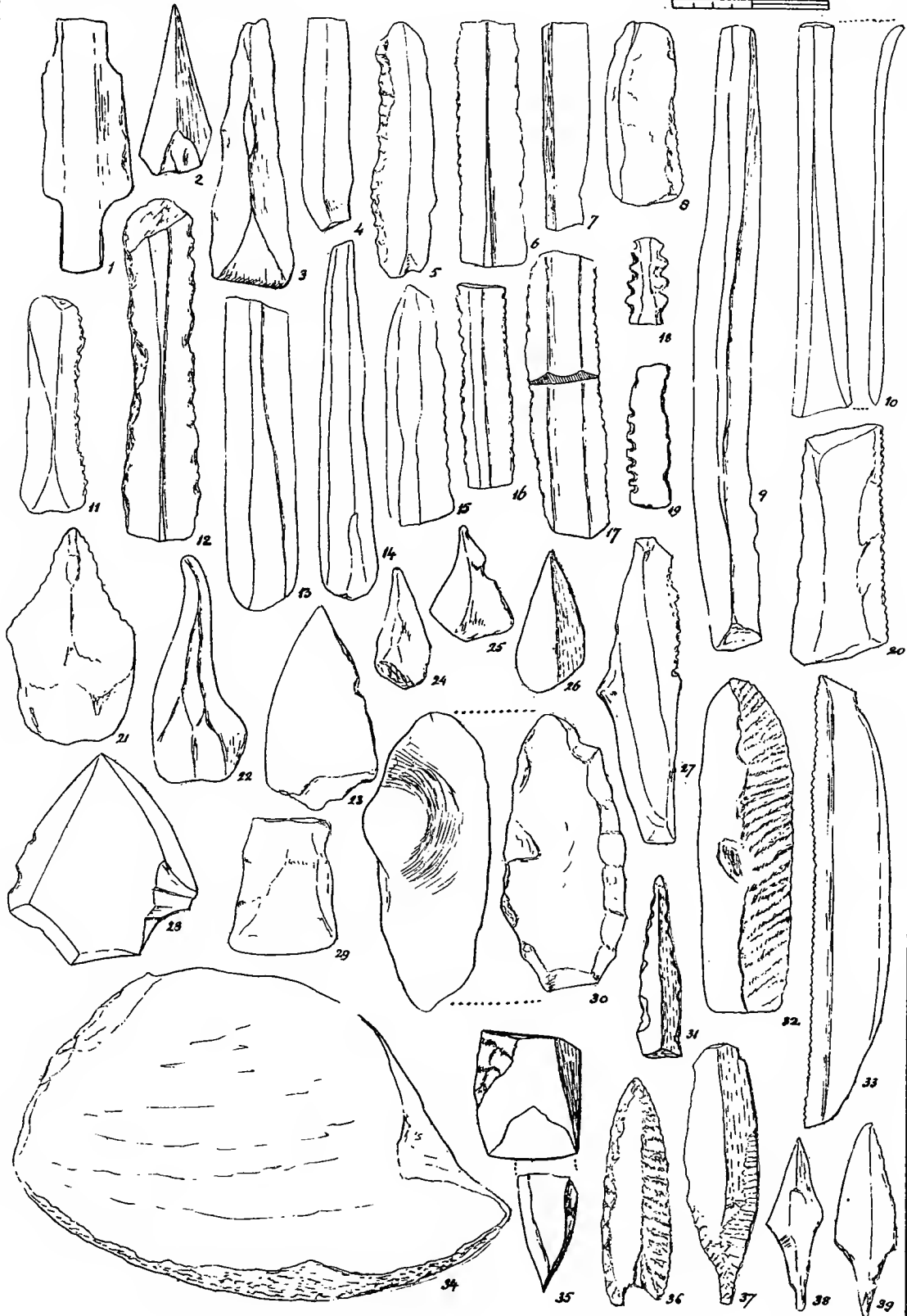
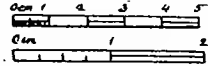





# FLINT IMPLEMENTS

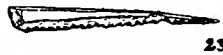
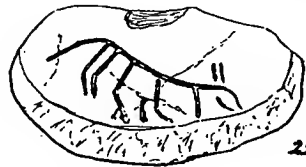
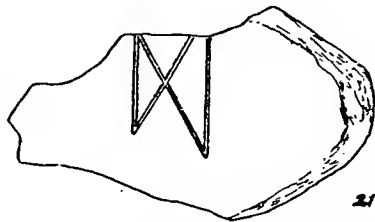
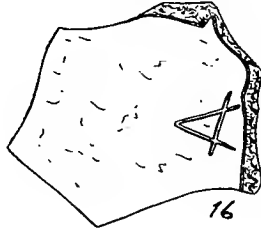
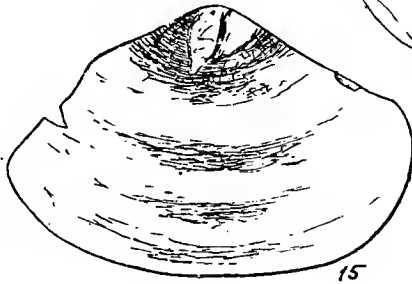
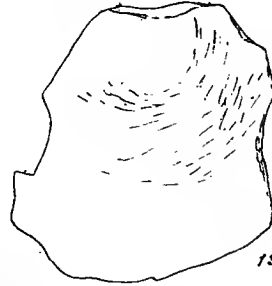
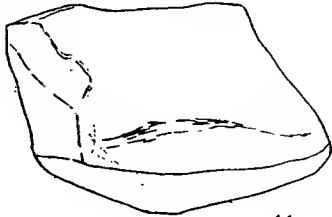
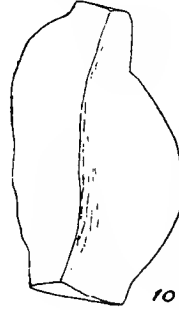
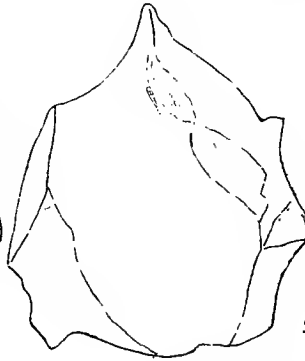
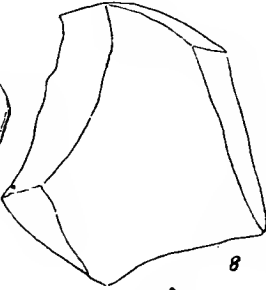
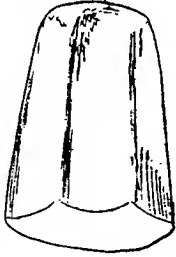
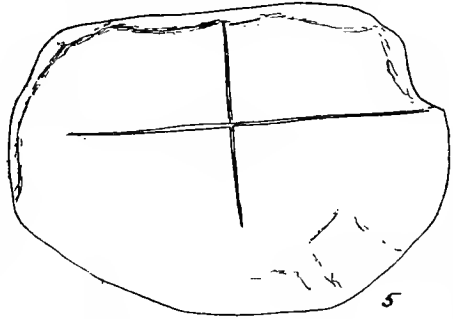
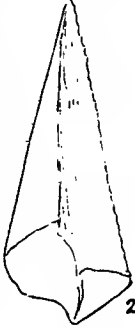
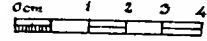
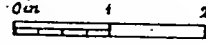



POTTERY: COLOUR DECORATION (VARIOUS PERIODS)







FIRST SEMITIC POTTERY

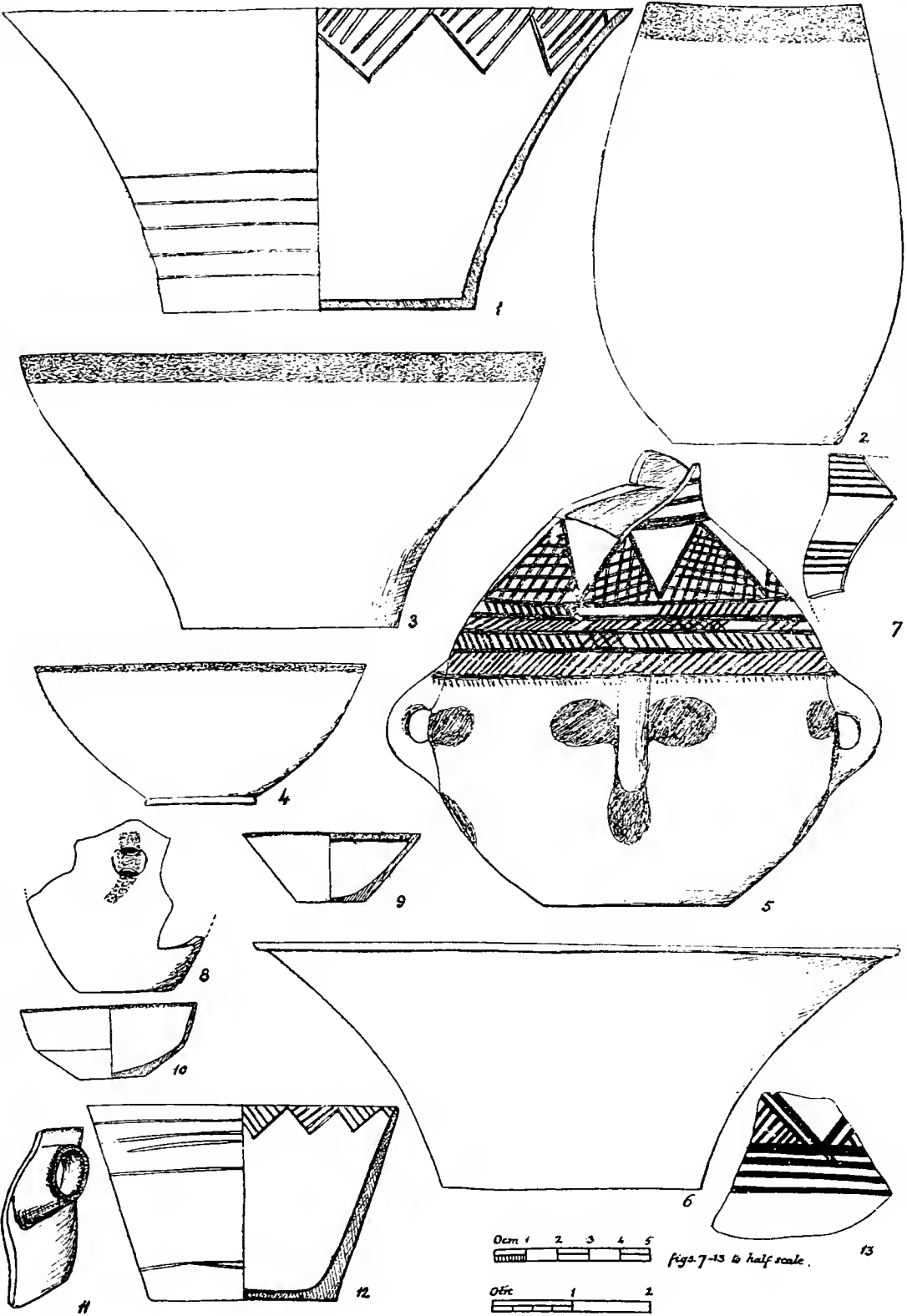

# FIRST SEMITIC POTTERY

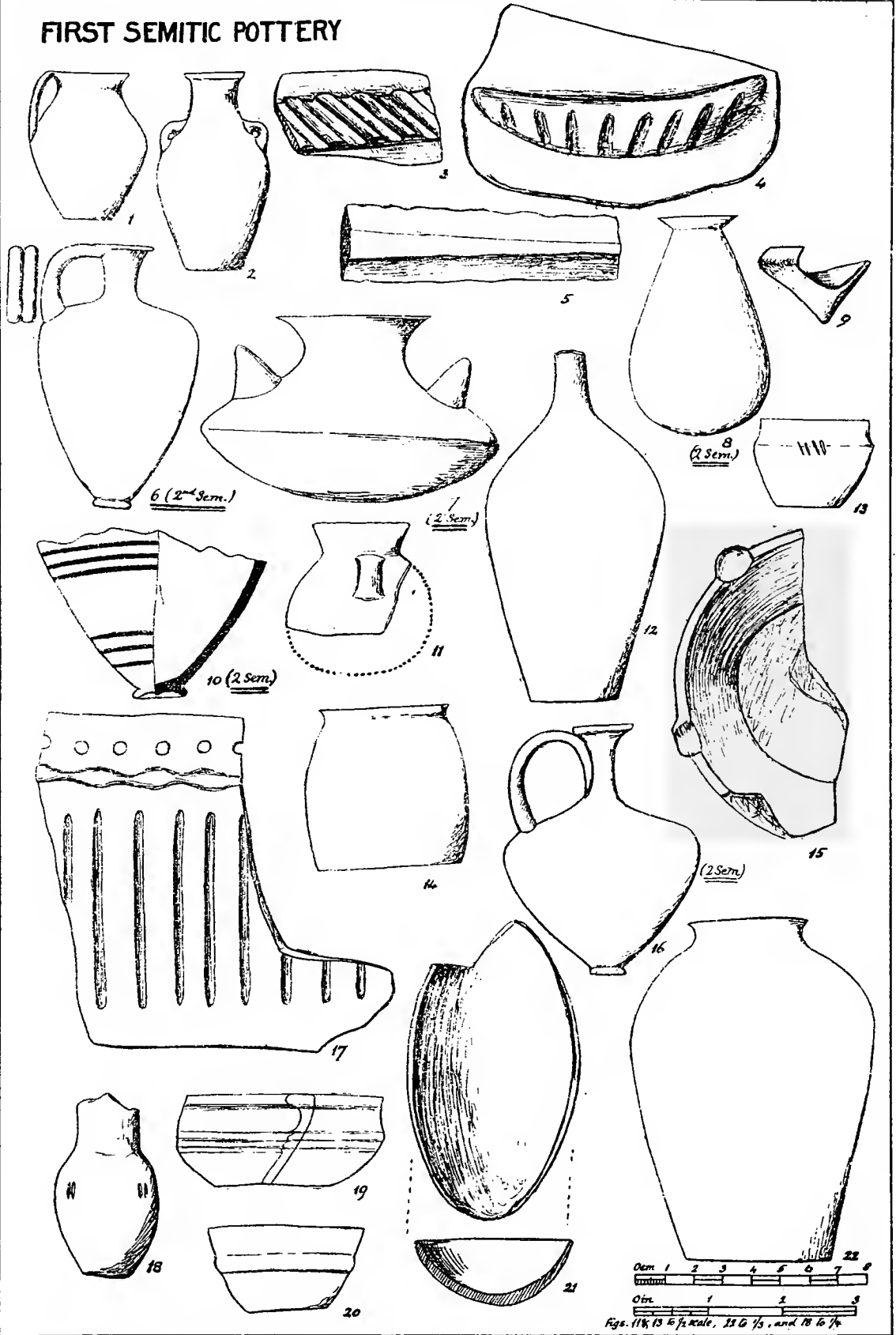







FIRST SEMITIC POTTERY



0 in 1 2

0 cm 1 2 3 4 5

figs 13, 14, 19, 21, to half scale

FIRST SEMITIC POTTERY

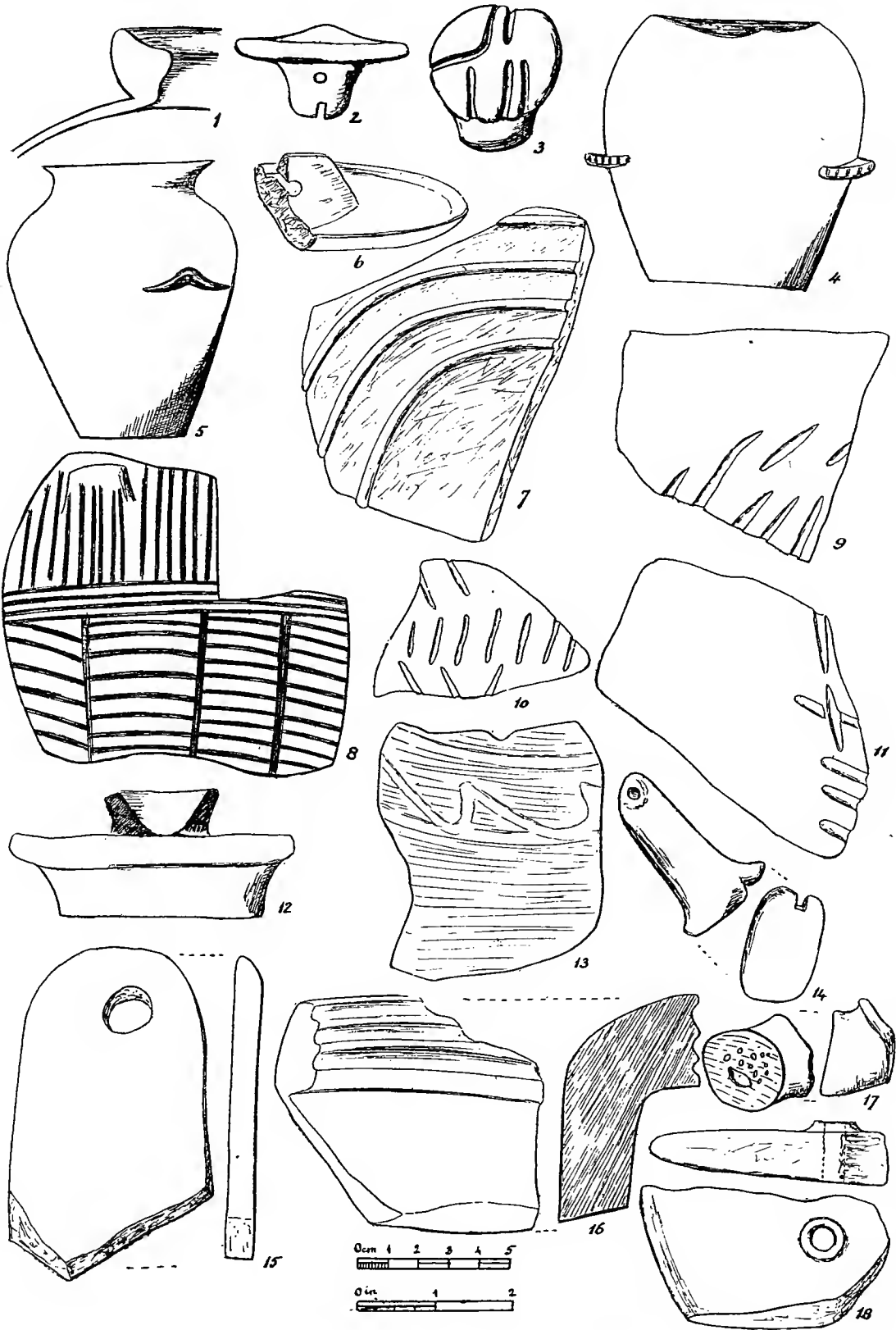





FIRST SEMITIC PERIOD

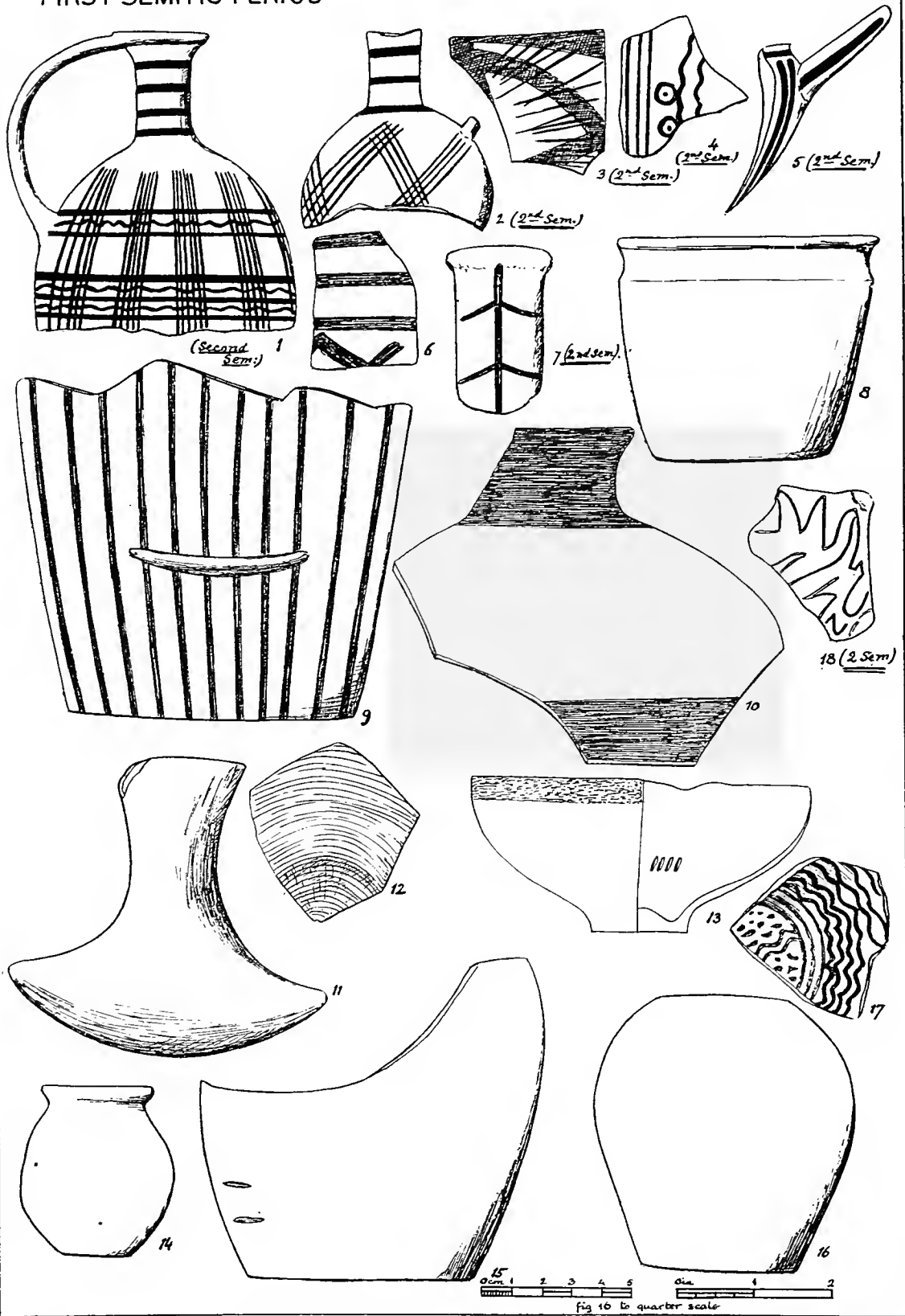

FIRST SEMITIC POTTERY

1cm 0 1 2 3 4

1cm 0 1

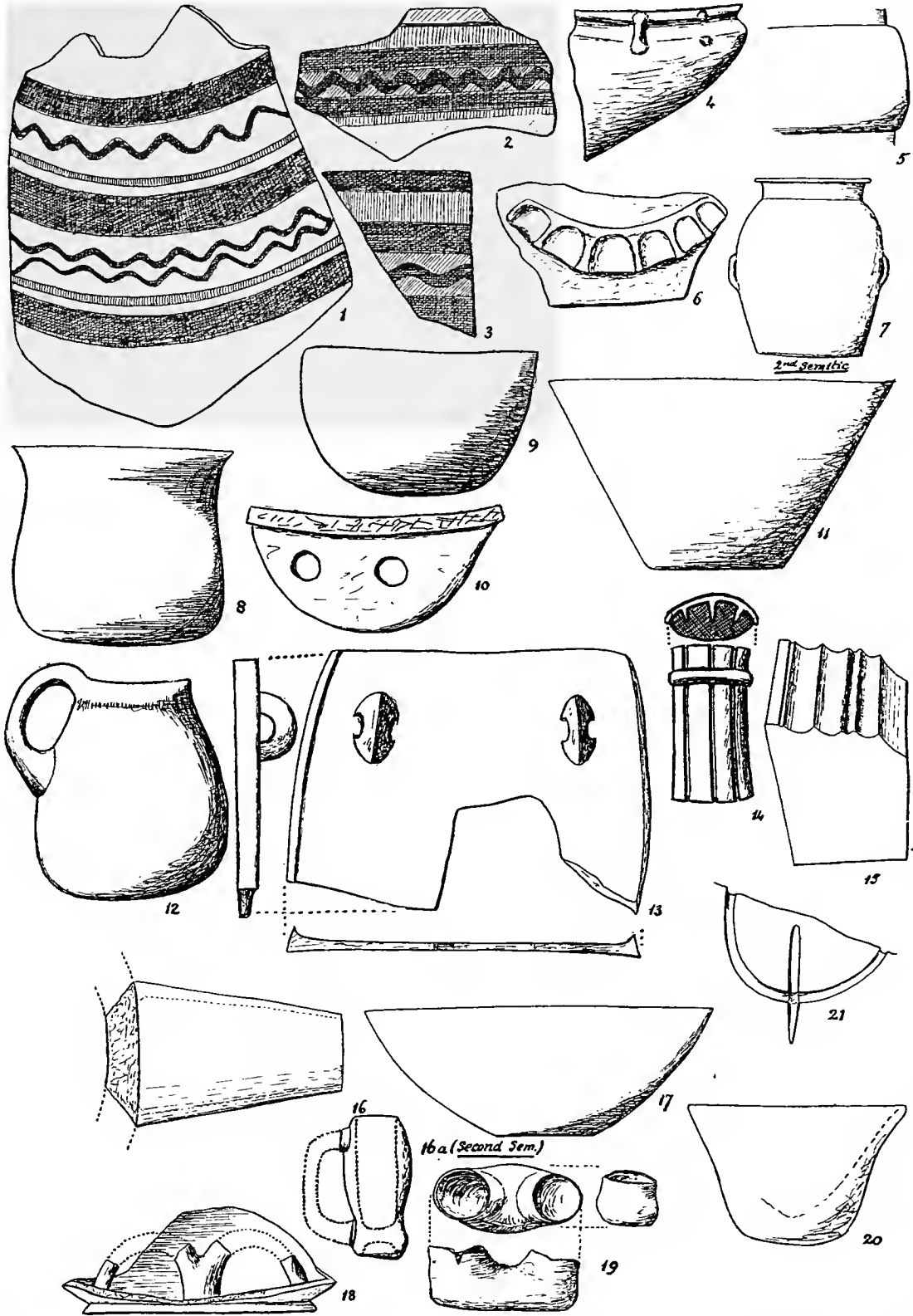







FIRST SEMITIC POTTERY

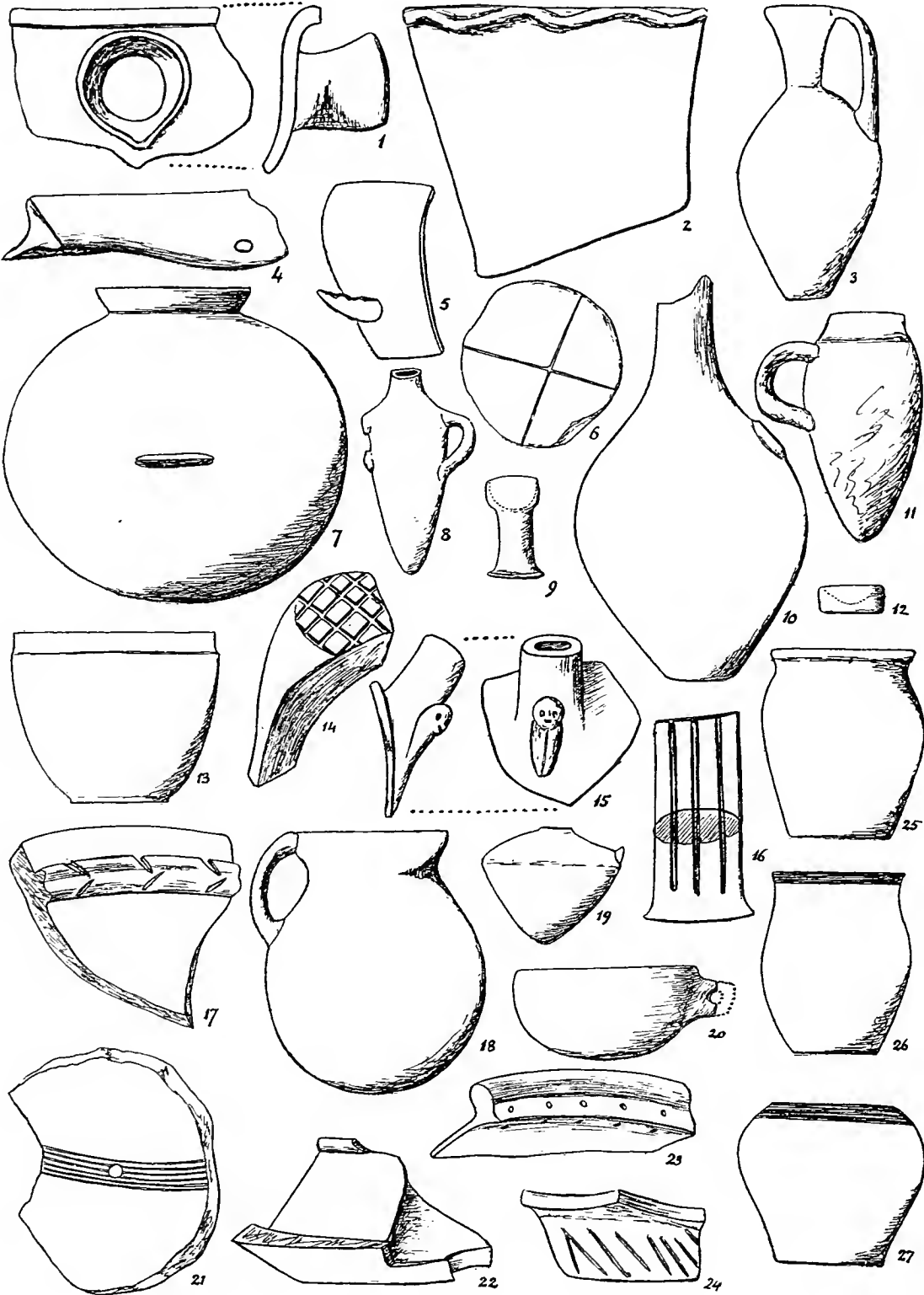
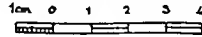

FIRST SEMITIC POTTERY

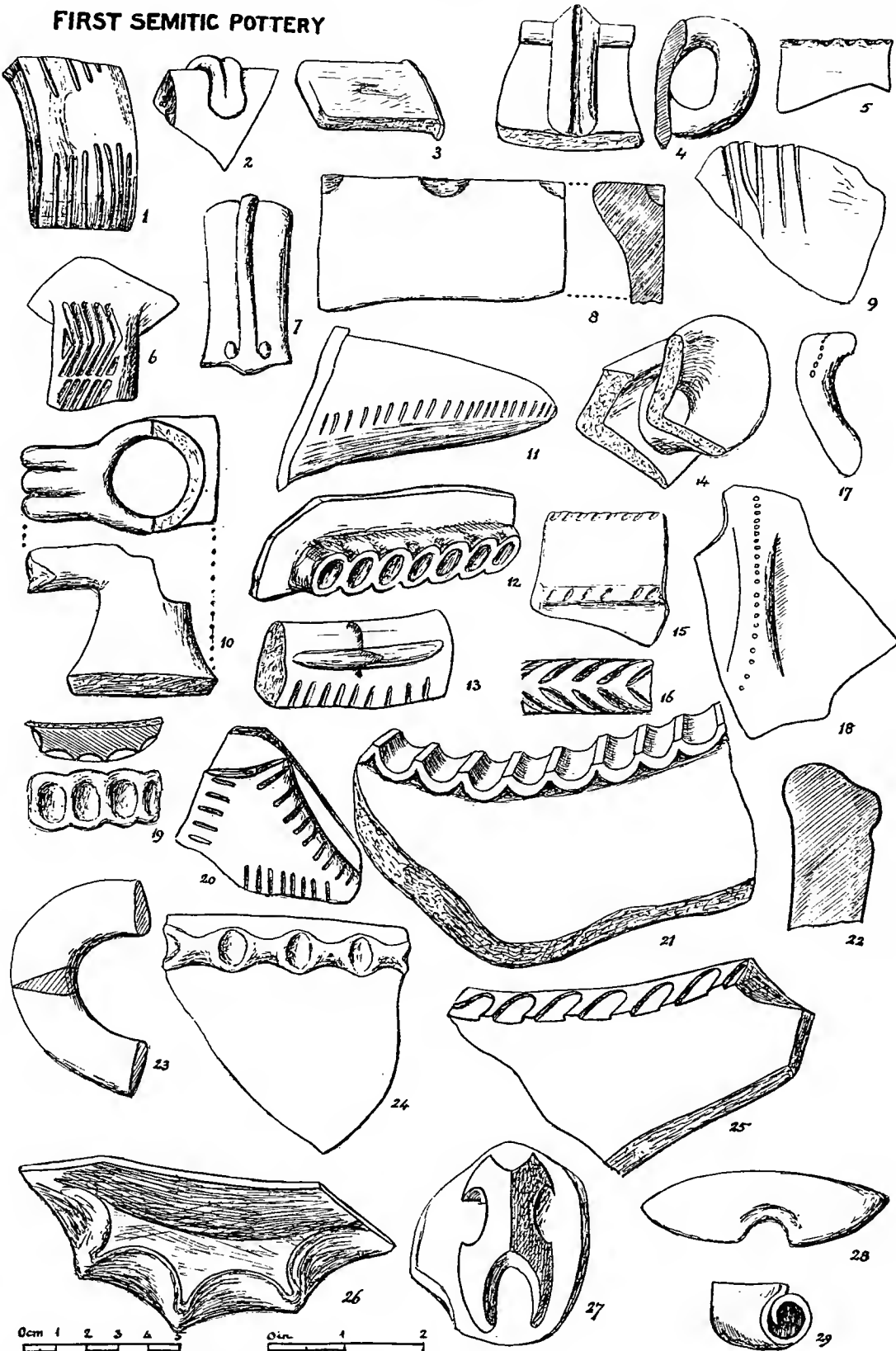

0cm 1 2 3 4 5

0in. 1 2

figs. 3, 5, 6, 15 to  $\frac{3}{4}$  scale: fig. 29 to a slightly enlarged scale





# FIRST SEMITIC POTTERY

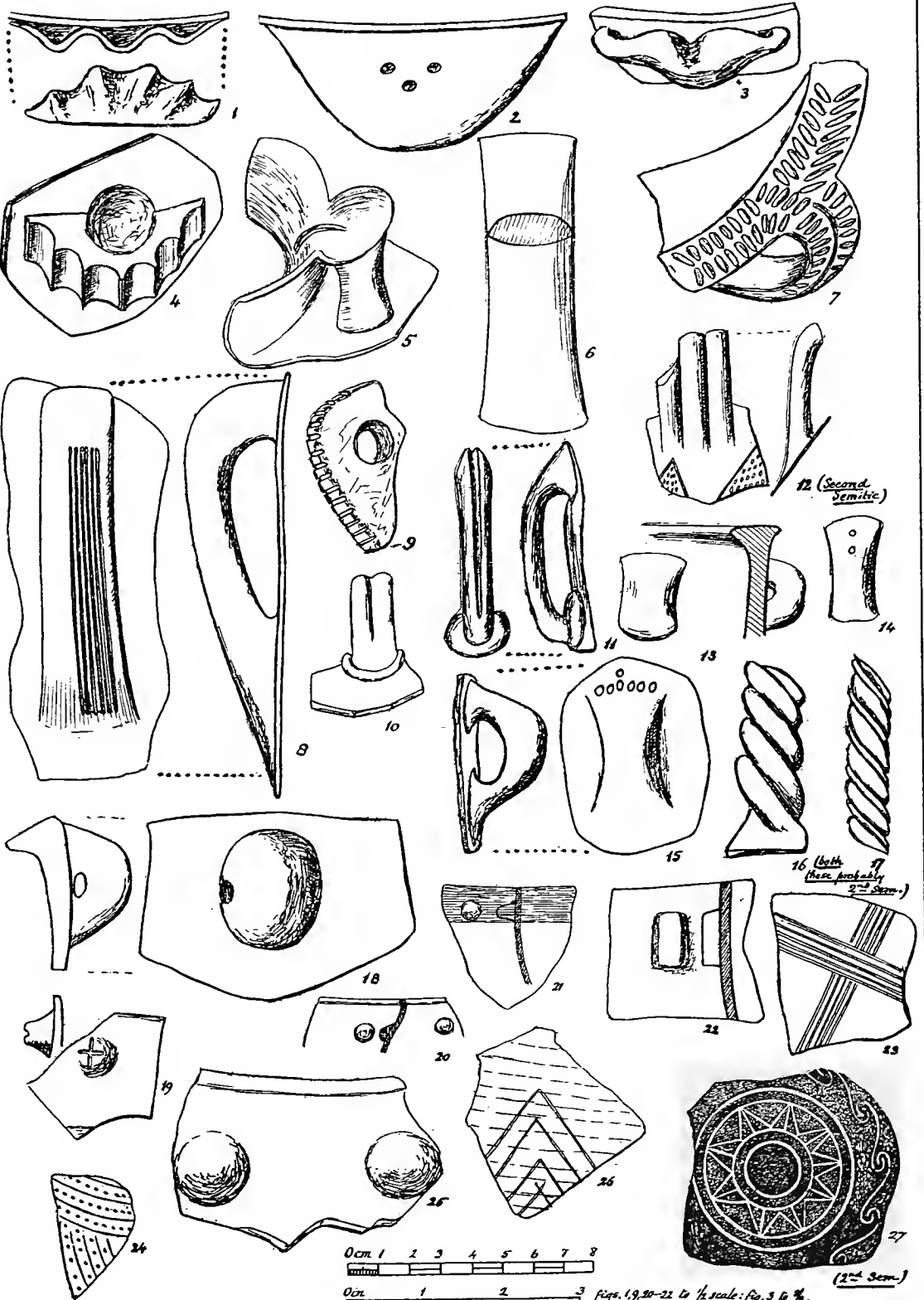

Figs. 19, 20-22 to 1/2 scale; fig. 3 to 1/4.

(2<sup>nd</sup> Sem.)

# FIRST SEMITIC POTTERY

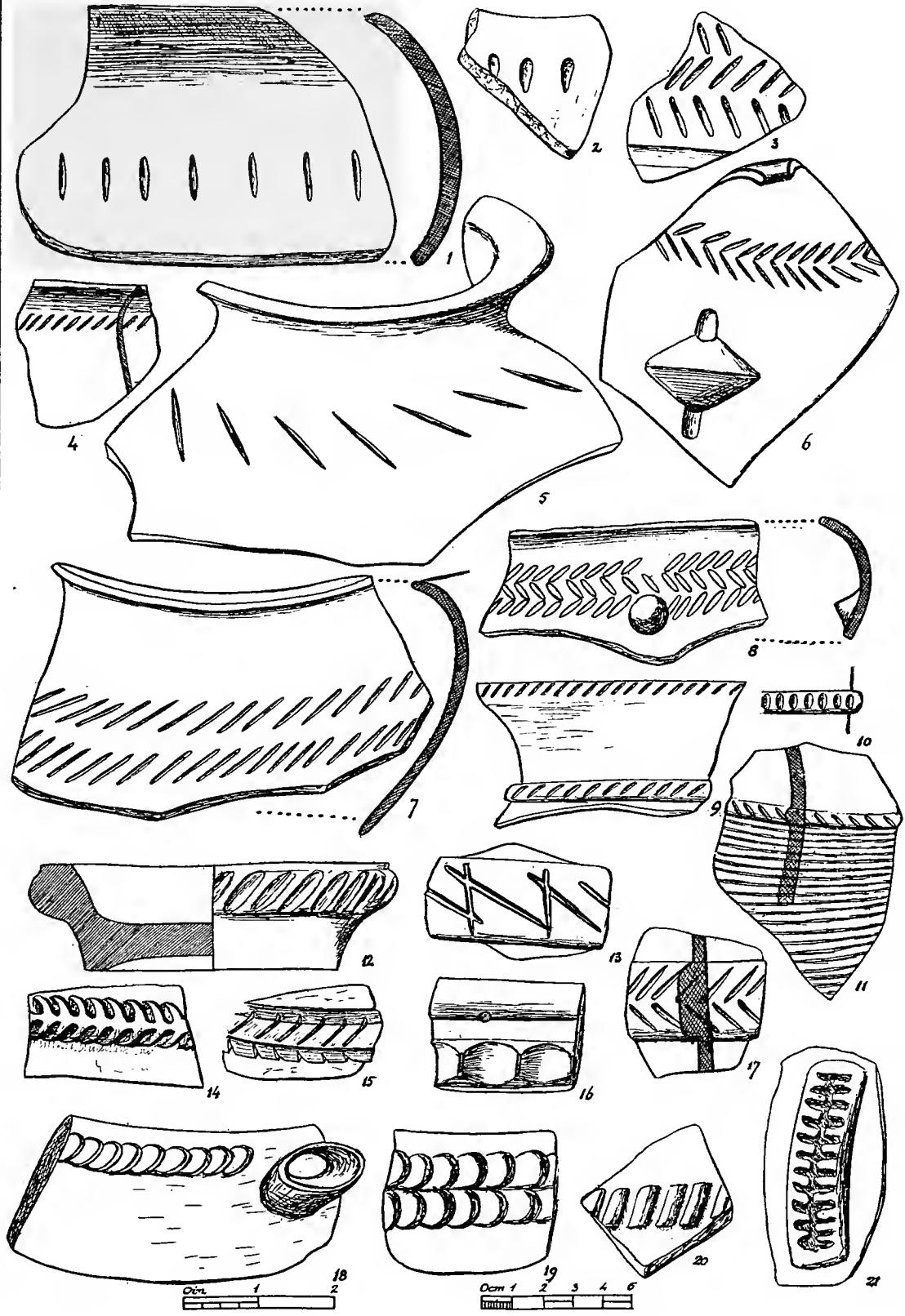







ÆGEAN POTSHERDS

1cm 0 1 2 3 1 in. 0 1

fig. 8 to 3/4, fig. 9 to 1/2 scale



SECOND SEMITIC POTTERY

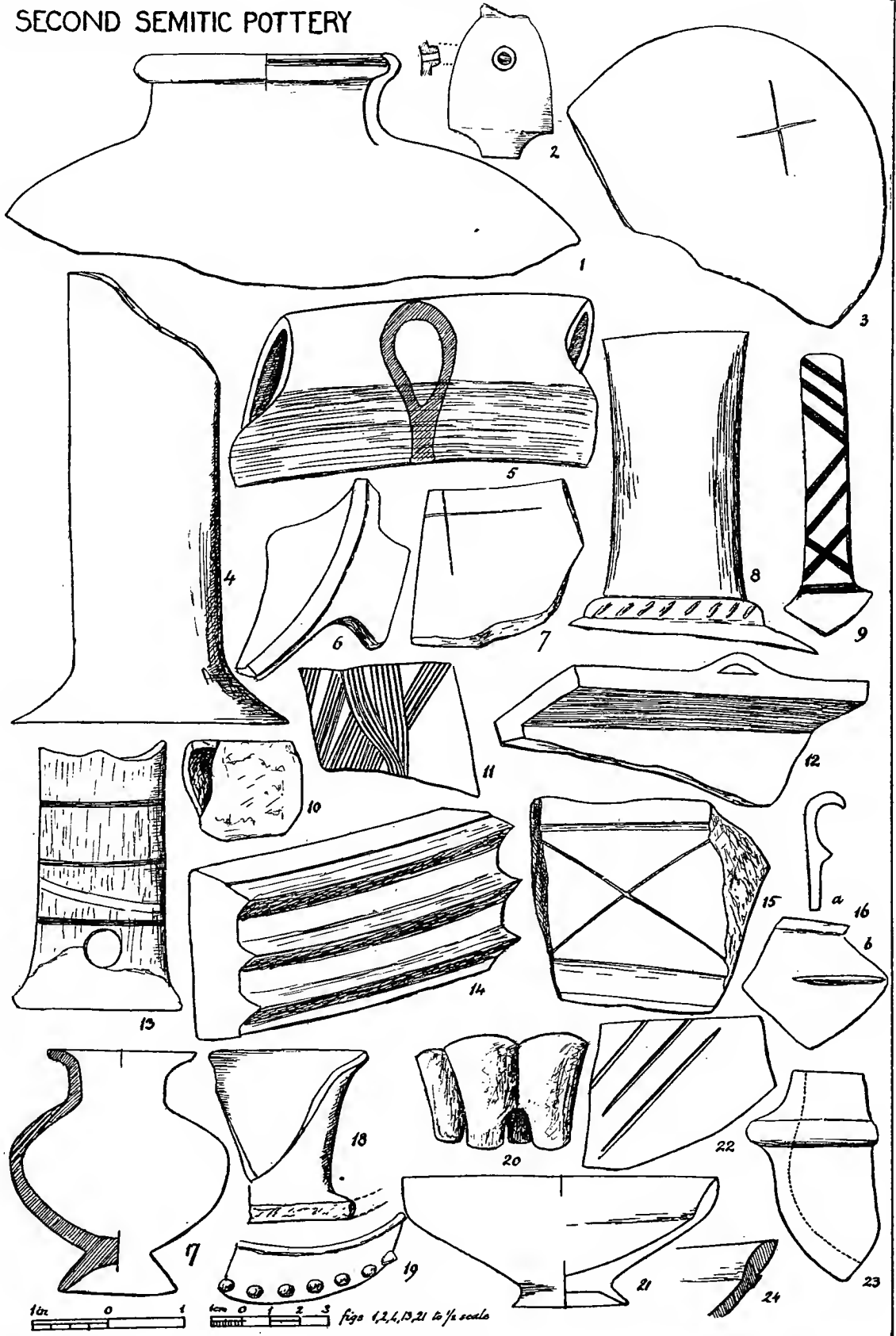

10x 0 1 cm 0 2 3 figs 1,2,4,13,21 to 1/2 scale





SECOND SEMITIC POTTERY

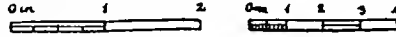

*Figs. 12, 16, 17, 19, 22 to 1/2 scale*

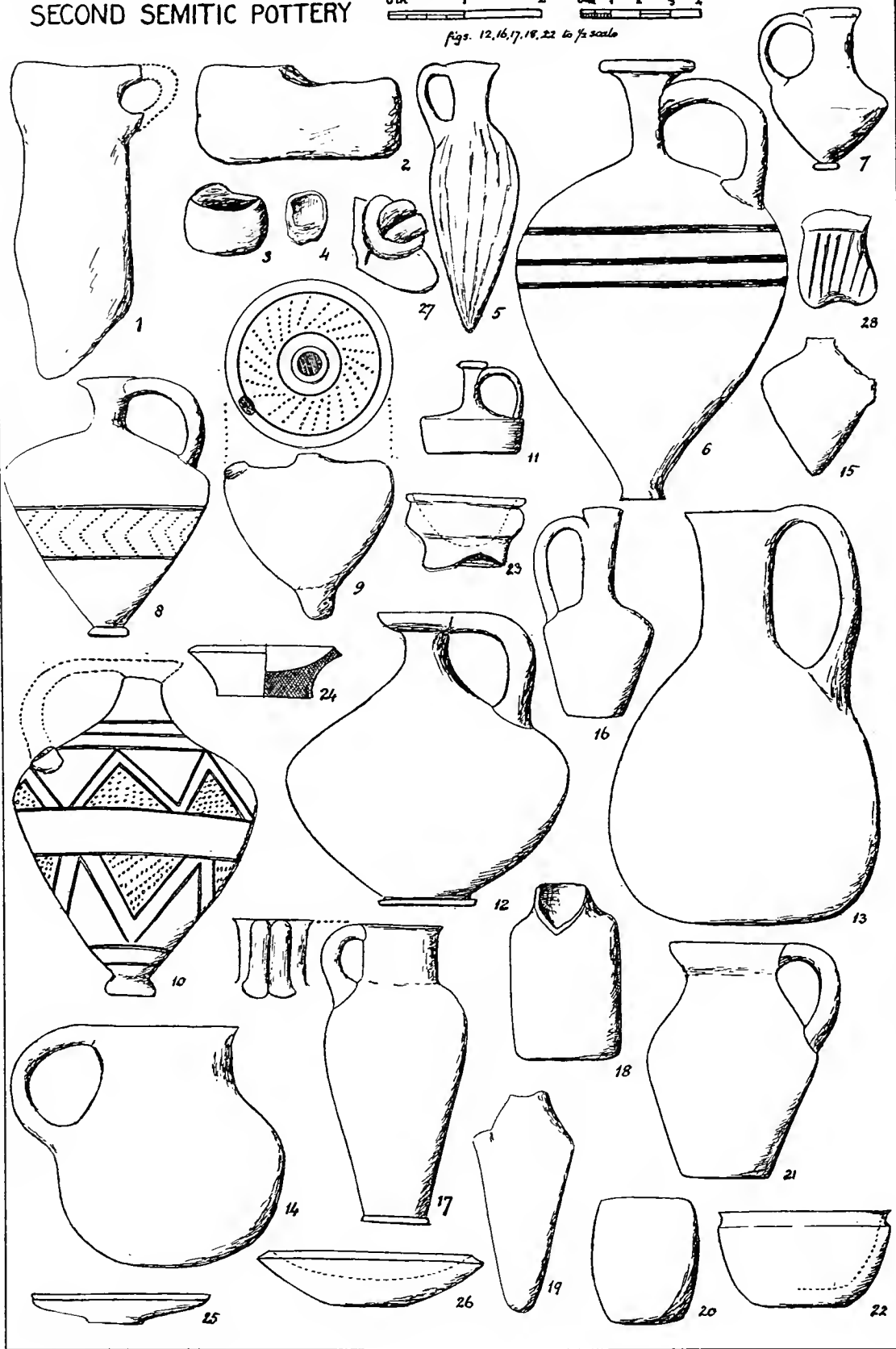

# SECOND SEMITIC POTTERY

0 in. 1 2      0 cm 1 2 3 4

*figs. 4, 6, 7, 11, 12, 18, 25 to 1/2 sca.*

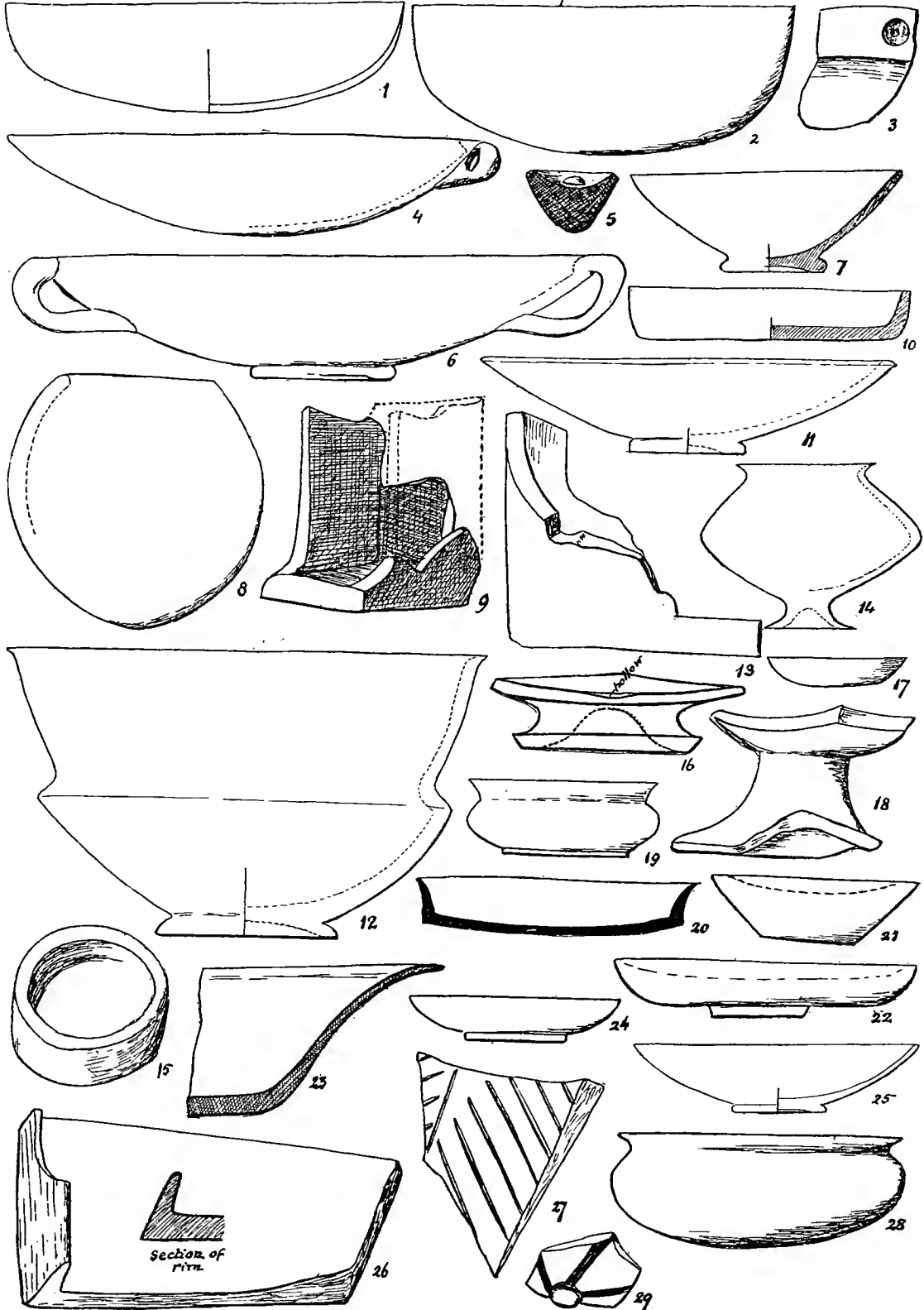







SECOND SEMITIC POTTERY

1 cm 0 1 1 cm 0 1 2 3 figs. 1, 16, 17 to 3/4. figs 9 to 14



SECOND SEMITIC POTTERY

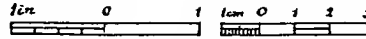

figs 1, 1, 8, 9, 21, 25 to 1/2  
fig 13 to one-eighth.

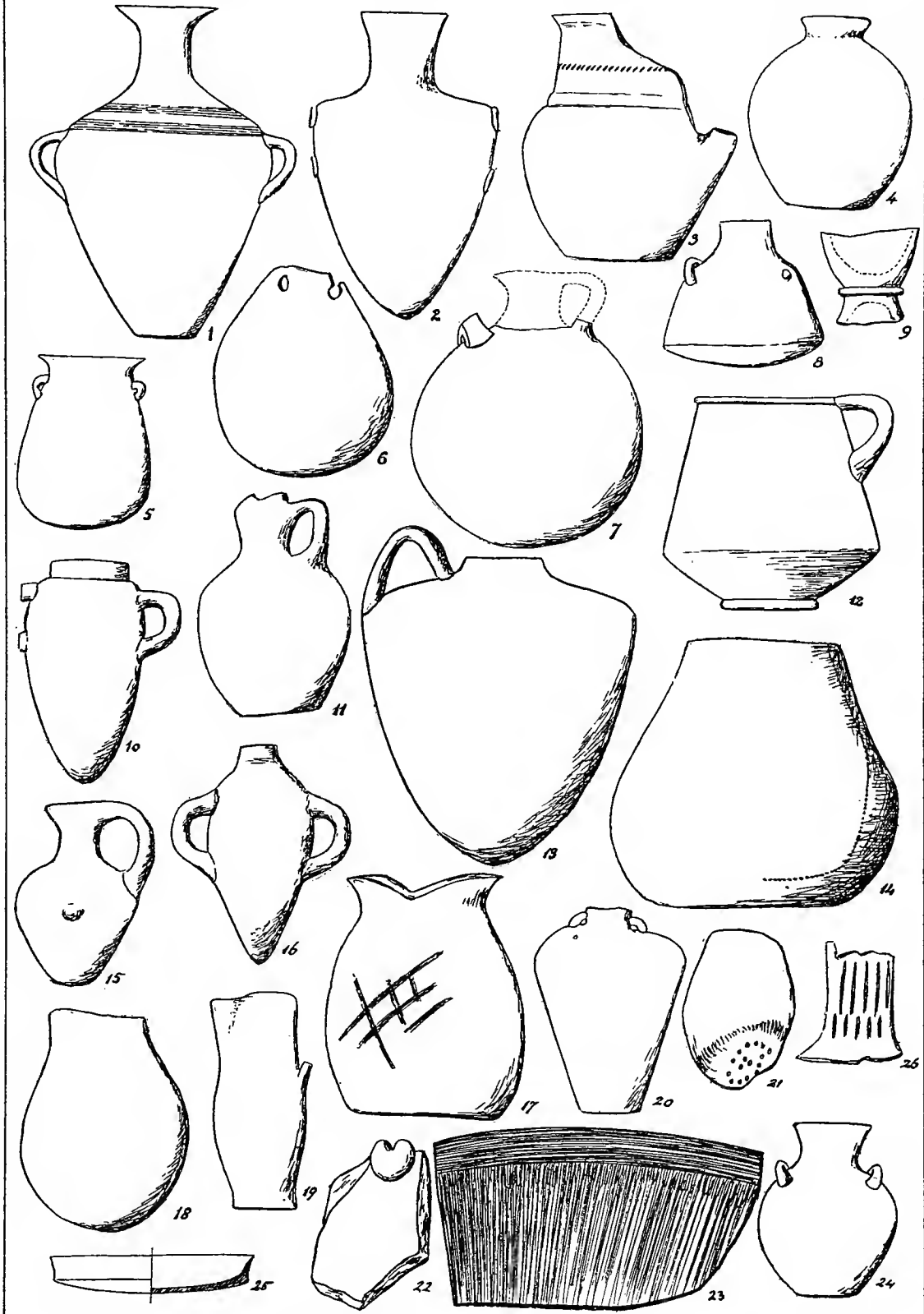





SECOND SEMITIC POTTERY

1 cm 0 1 1 cm 0 1 2 3 fig. 16 to 24, fig. 23 to 25



# THIRD SEMITIC POTTERY

1 in. 0 1 1 cm 0 1 2 3 4  
figs 1, 3, 7, 9-12, 14 to 1/2 scale: fig. 15 is 8" (20.3 cm.) high

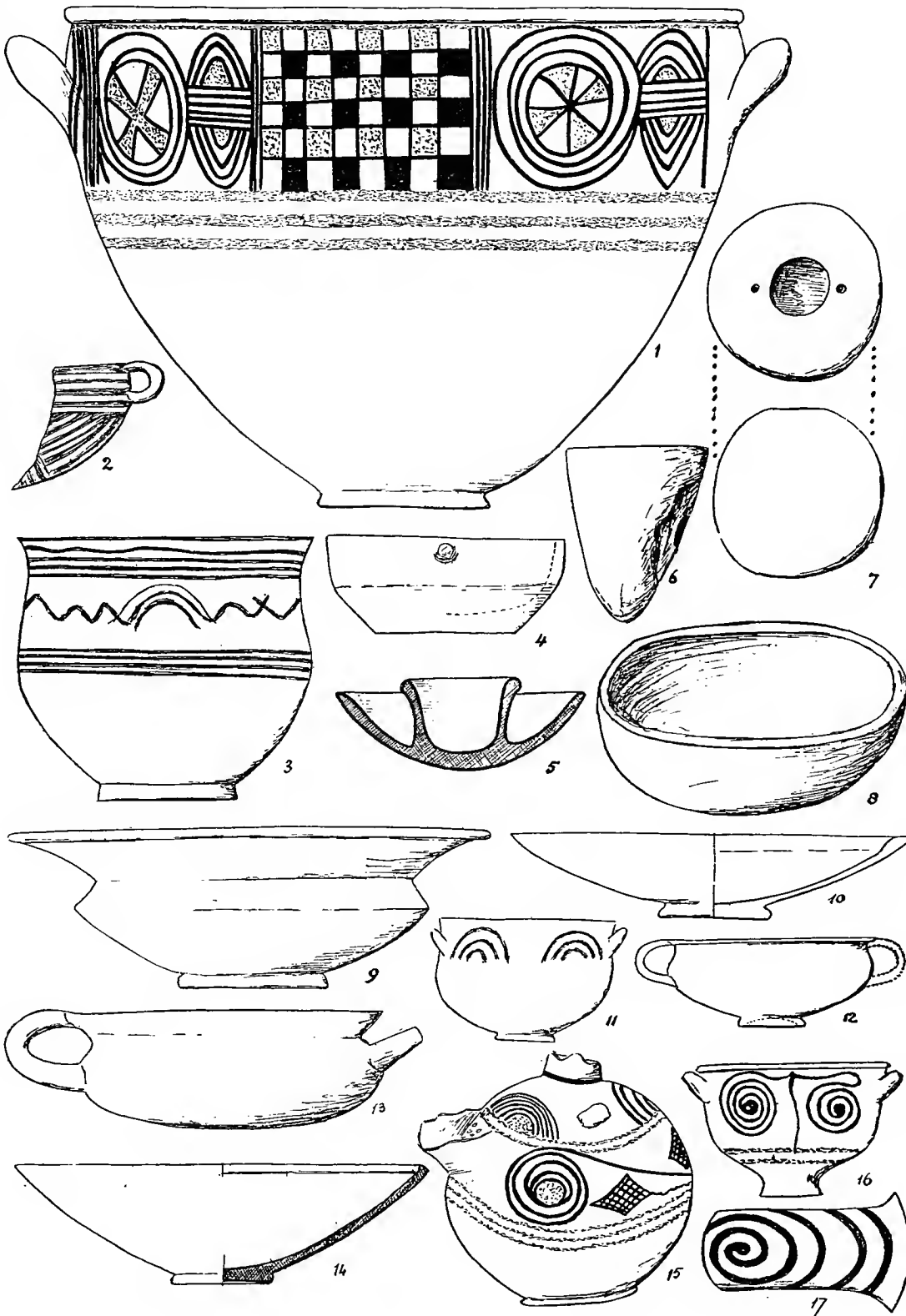





# THIRD SEMITIC POTTERY

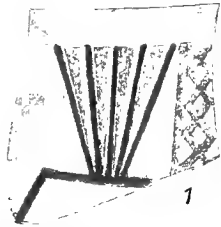
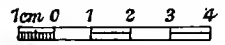
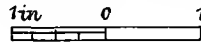

1

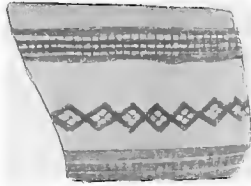

2



3



4



5



6



7

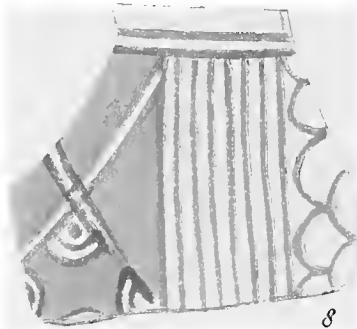

8

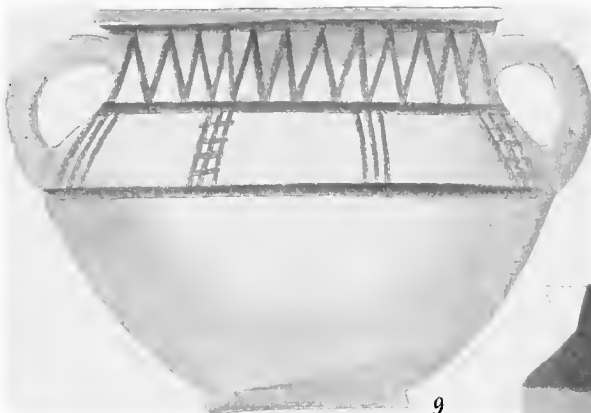

9



10



11



14



15



12



13



4<sup>th</sup> sem

17



18. 1<sup>st</sup> sem



16





# THIRD SEMITIC POTTERY

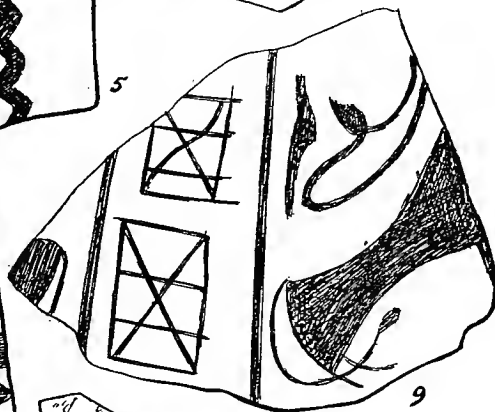
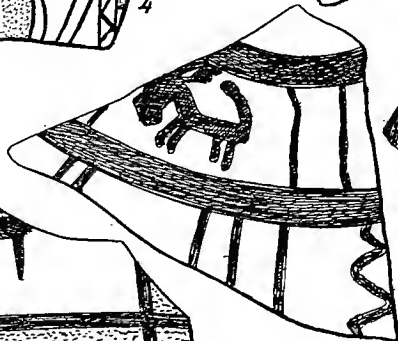
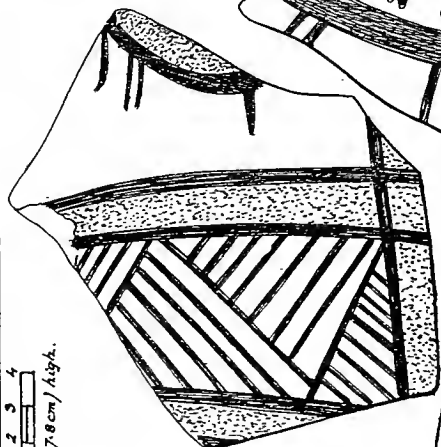
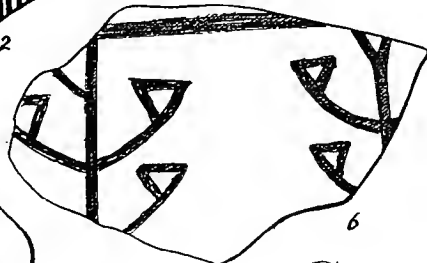
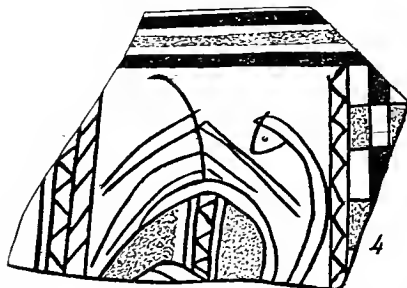
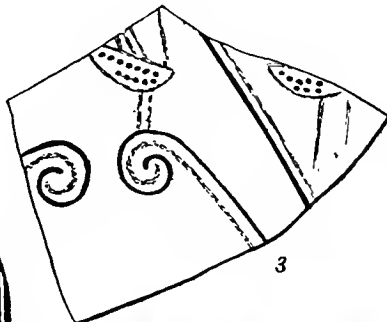
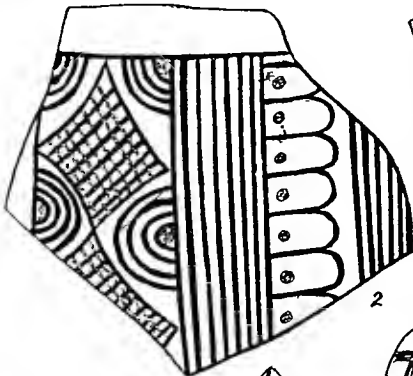

0 cm  
1 2 3 4  
Scale 1 2 3 4  
Fig 1 is 7" (17.8 cm) high.

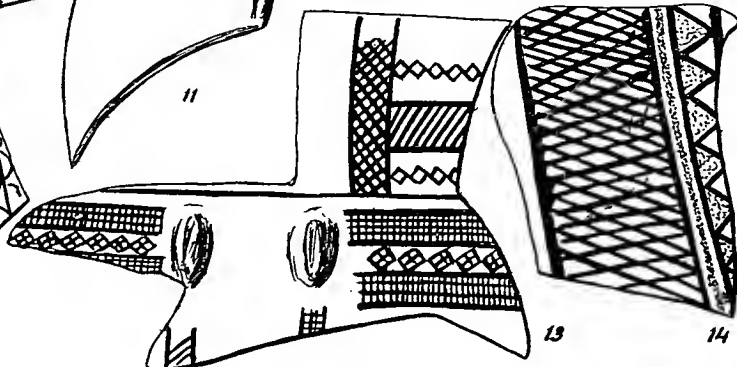
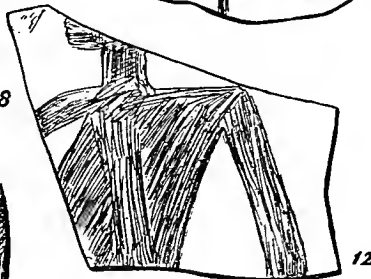
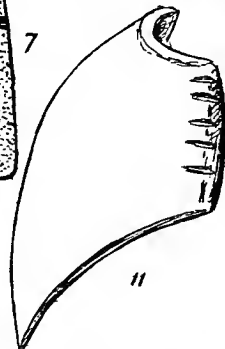
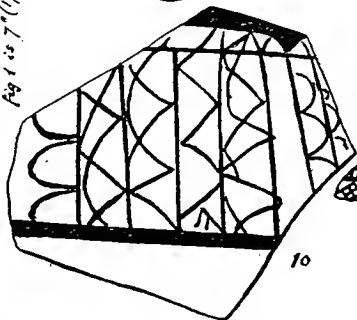

14

# THIRD SEMITIC POTTERY

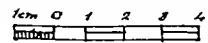
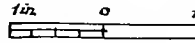

figs 1, 2, 4-8, 11, 15 to 1/2 scale

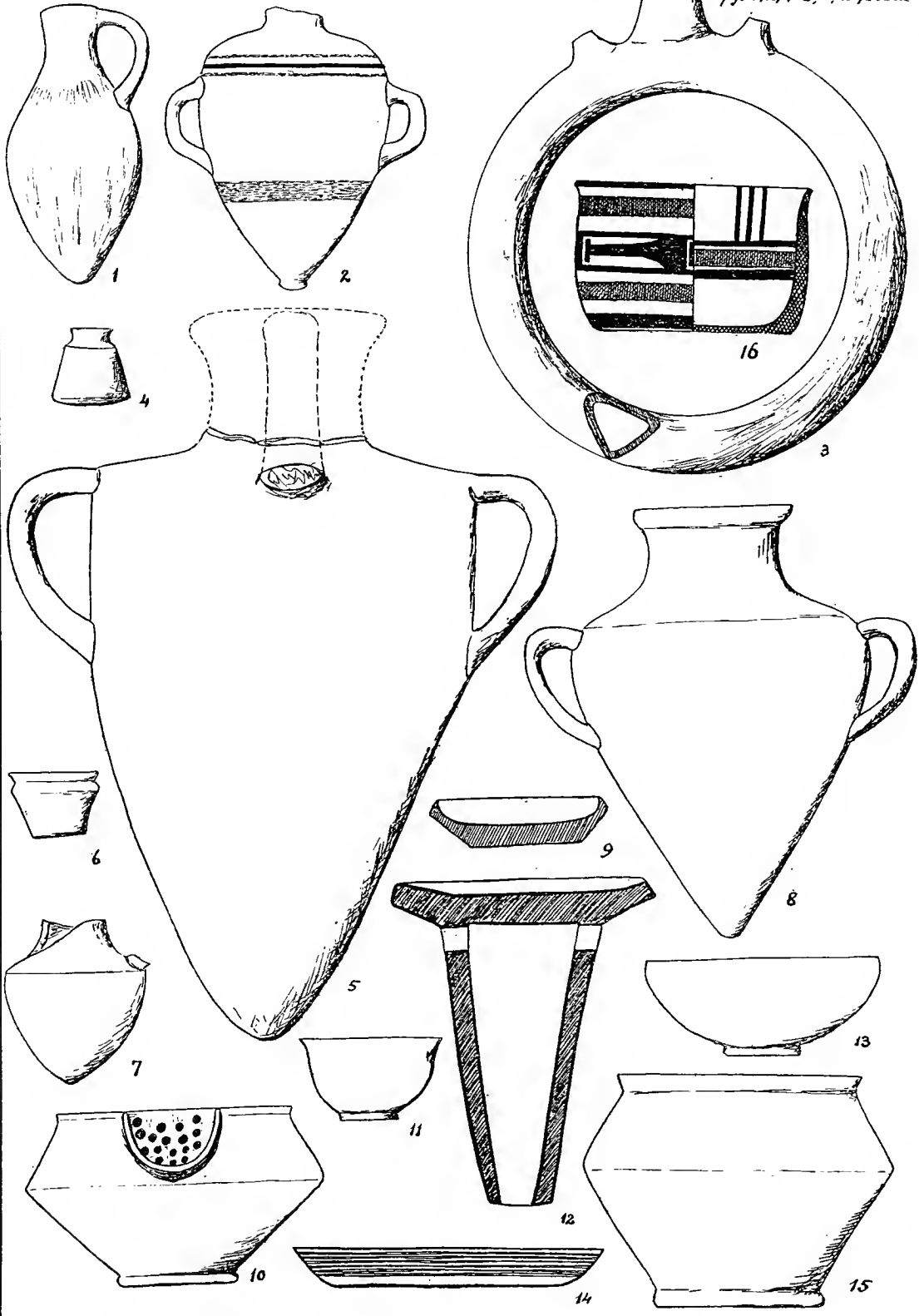







# THIRD SEMITIC POTTERY

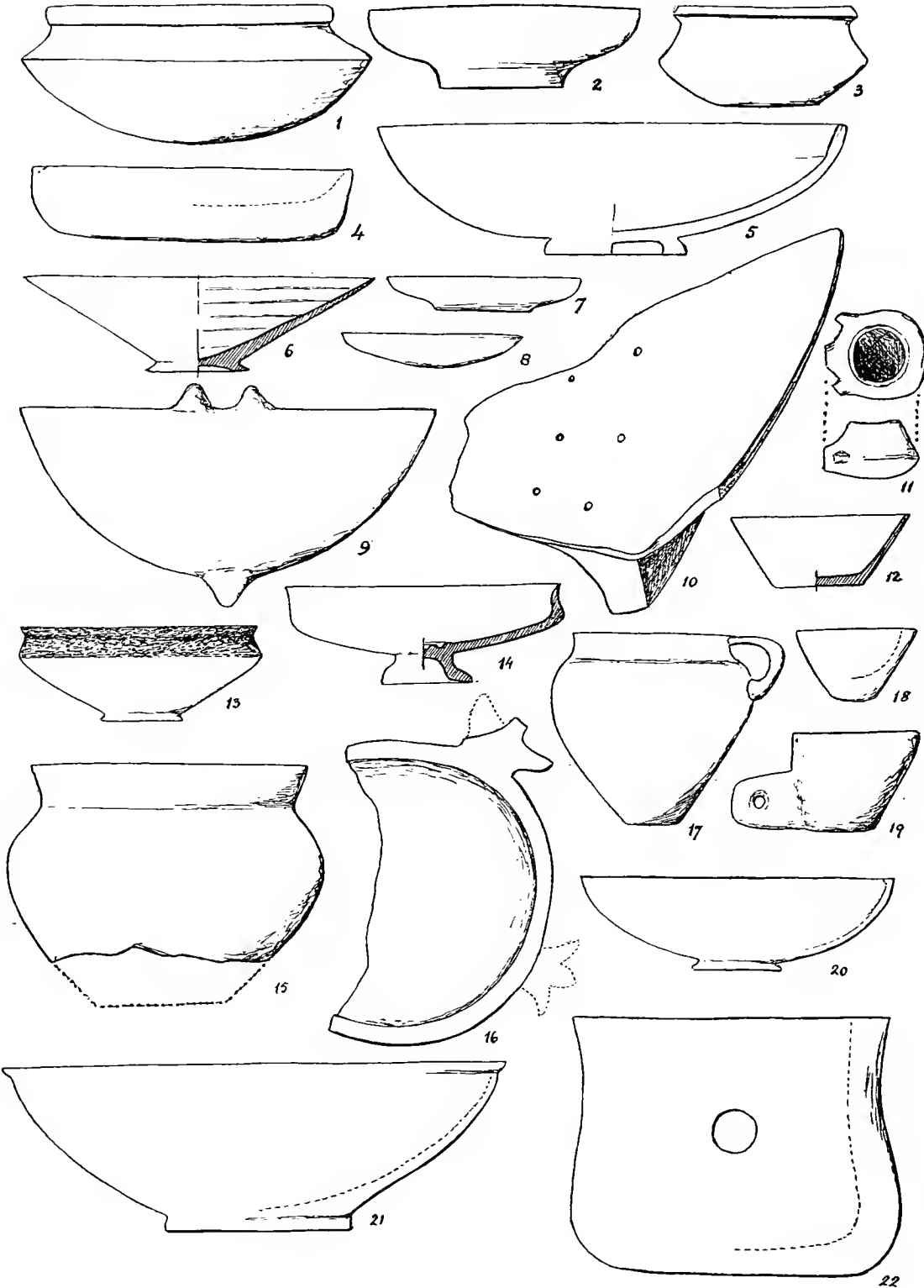
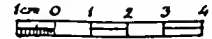
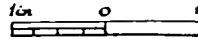

# THIRD SEMITIC POTTERY

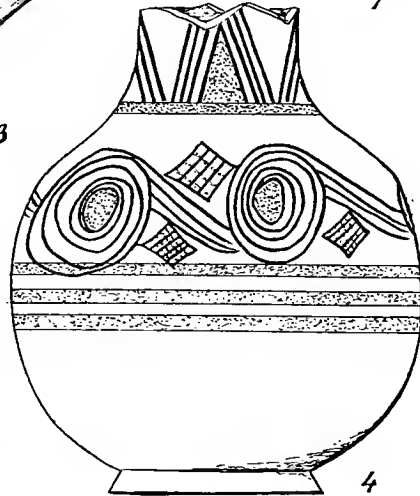
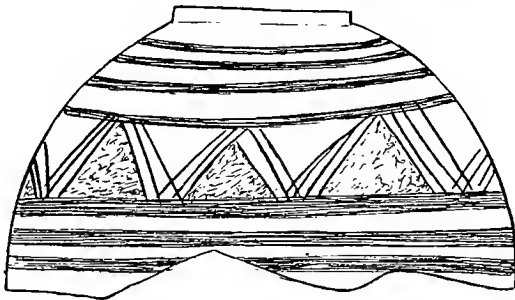
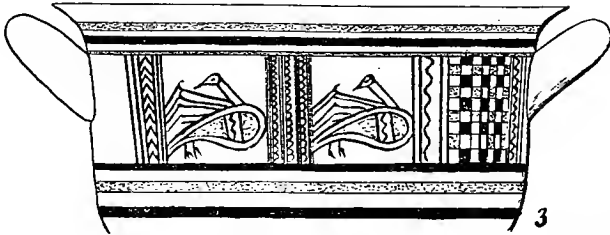
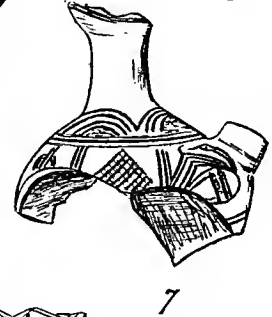
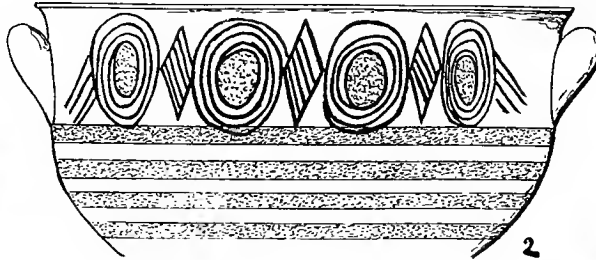
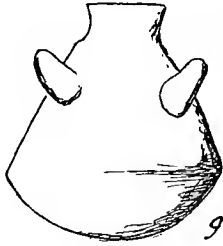
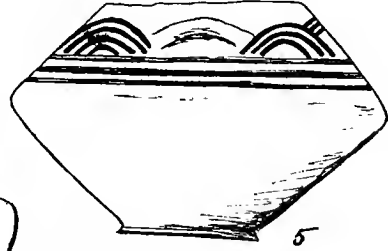
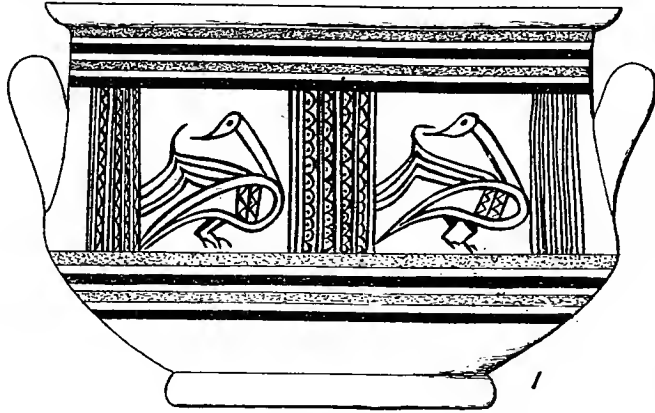

*development of the painted frieze, fig. 7.*





# THIRD SEMITIC POTTERY

1 in. 0 1 1 cm 0 1 2

figs 1, 4-6, 8, 9, 12, 15, 18, 21 to scale

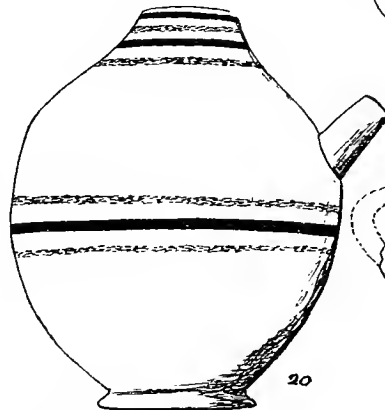
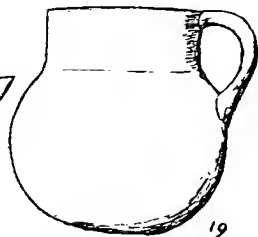
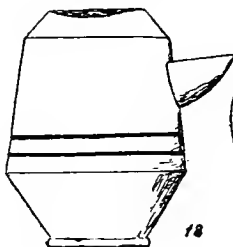
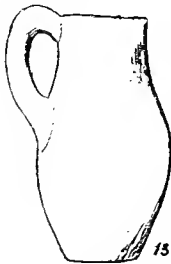
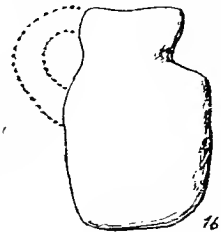
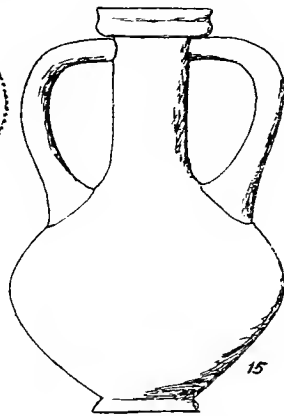
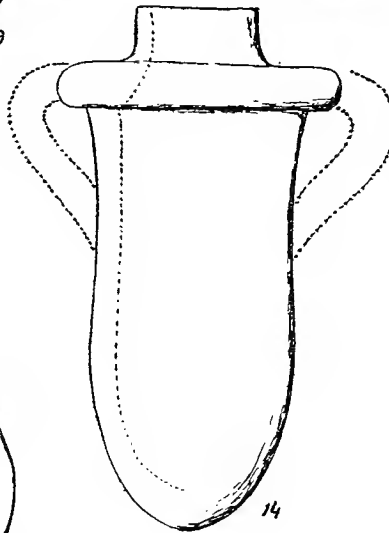
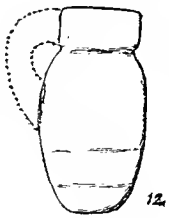
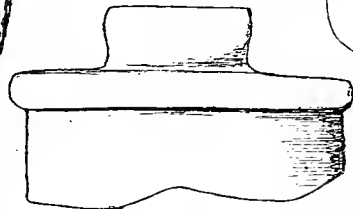
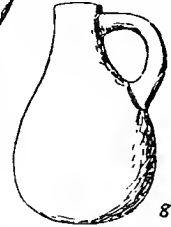
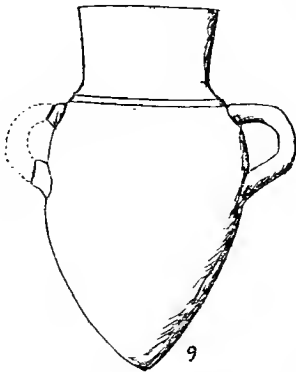
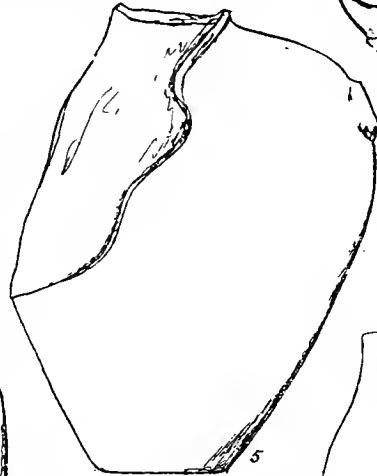
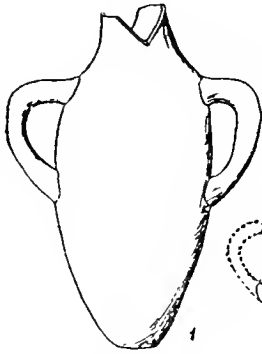

# THIRD SEMITIC POTTERY

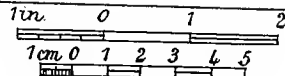



# THIRD SEMITIC POTTERY

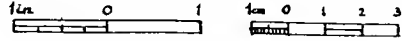

fig. 14 to 16 scale









# THIRD SEMITIC POTTERY

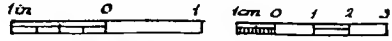
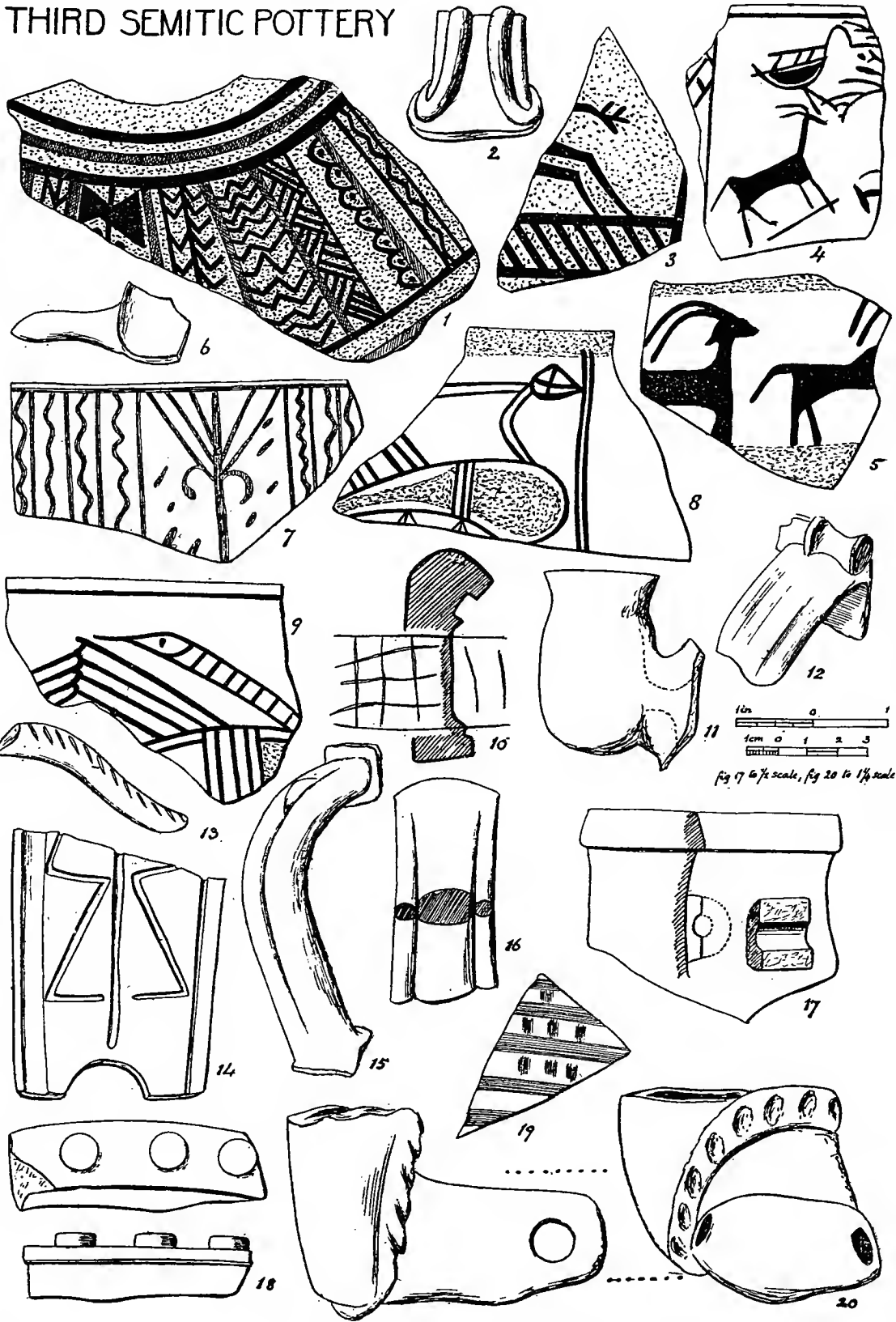

fig. 10 to  $\frac{3}{4}$  scale, 11 to ft., 16 to  $\frac{1}{4}$



# THIRD SEMITIC POTTERY







# FOURTH SEMITIC POTTERY

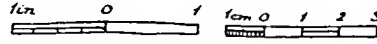

figs 2, 4, 8, 10, 12, 13, 17, 20 to  $\frac{3}{4}$  scale; fig 7 to  $\frac{1}{2}$  scale; Fig 16 is 6" (15.2cm) high

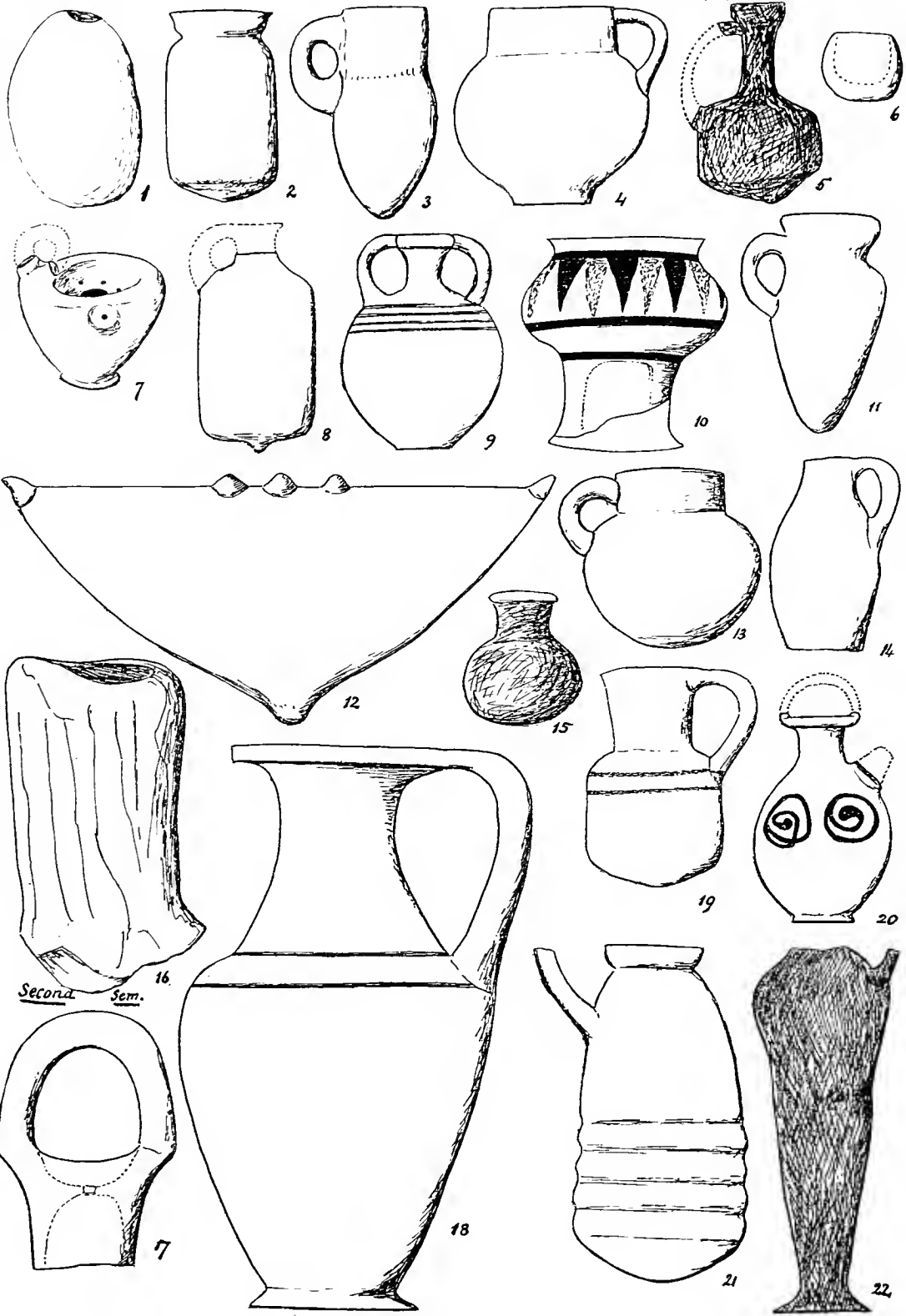

Second Sem.

# FOURTH SEMITIC POTTERY

1 dx 0 1 1 cm 0 1 2 3 4  
figs 3, 9, 10, 12 to 1/2 scale

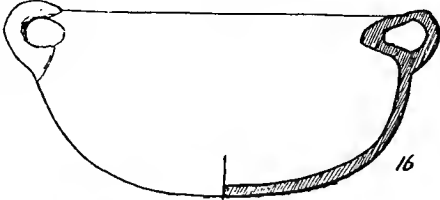
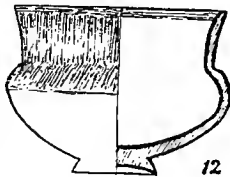
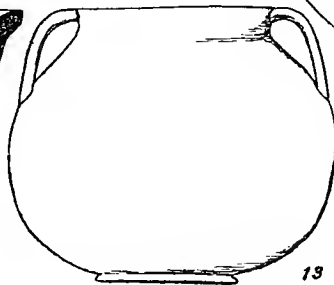
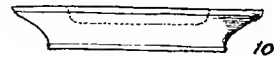
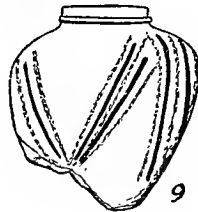
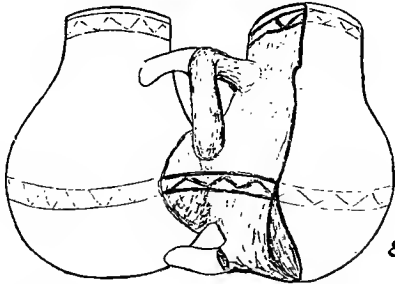
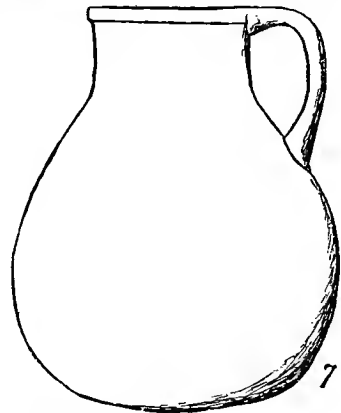
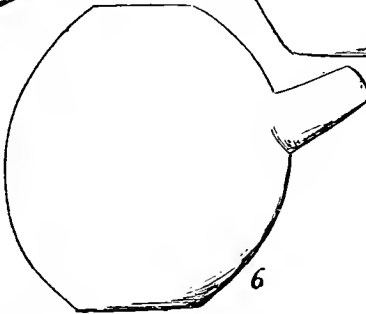
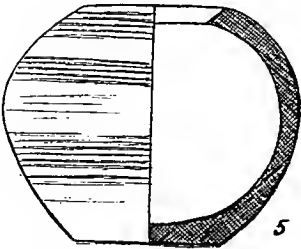
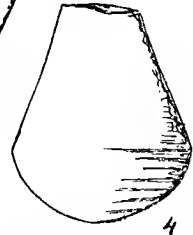
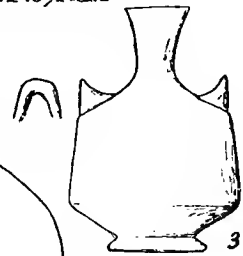
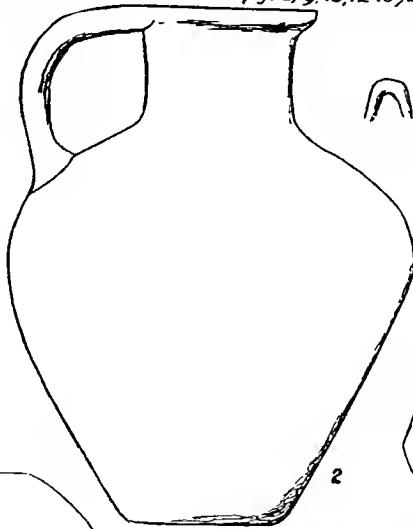
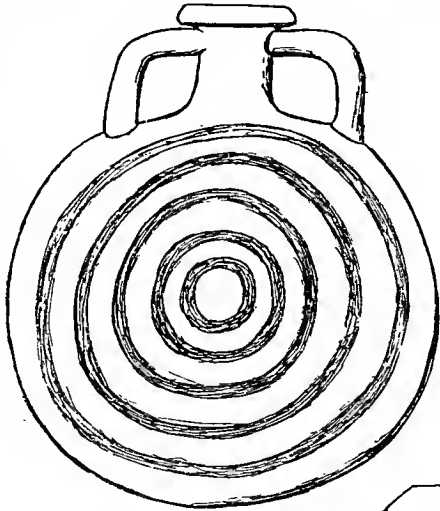







# FOURTH SEMITIC POTTERY

1 in. 0 1 2 3  
cm 0 1 2 3  
Figs 1, 2, 5, 8, 14 to scale



# FOURTH SEMITIC POTTERY

1 in 0 1 1 cm 0 1 2 3 4  
figs. 1, 4-7, 21 to 1/2, figs. 25, 26 to 3/4 scale







# FOURTH SEMITIC POTTERY

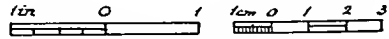

*figs 4, 6 to 1/2 scale*

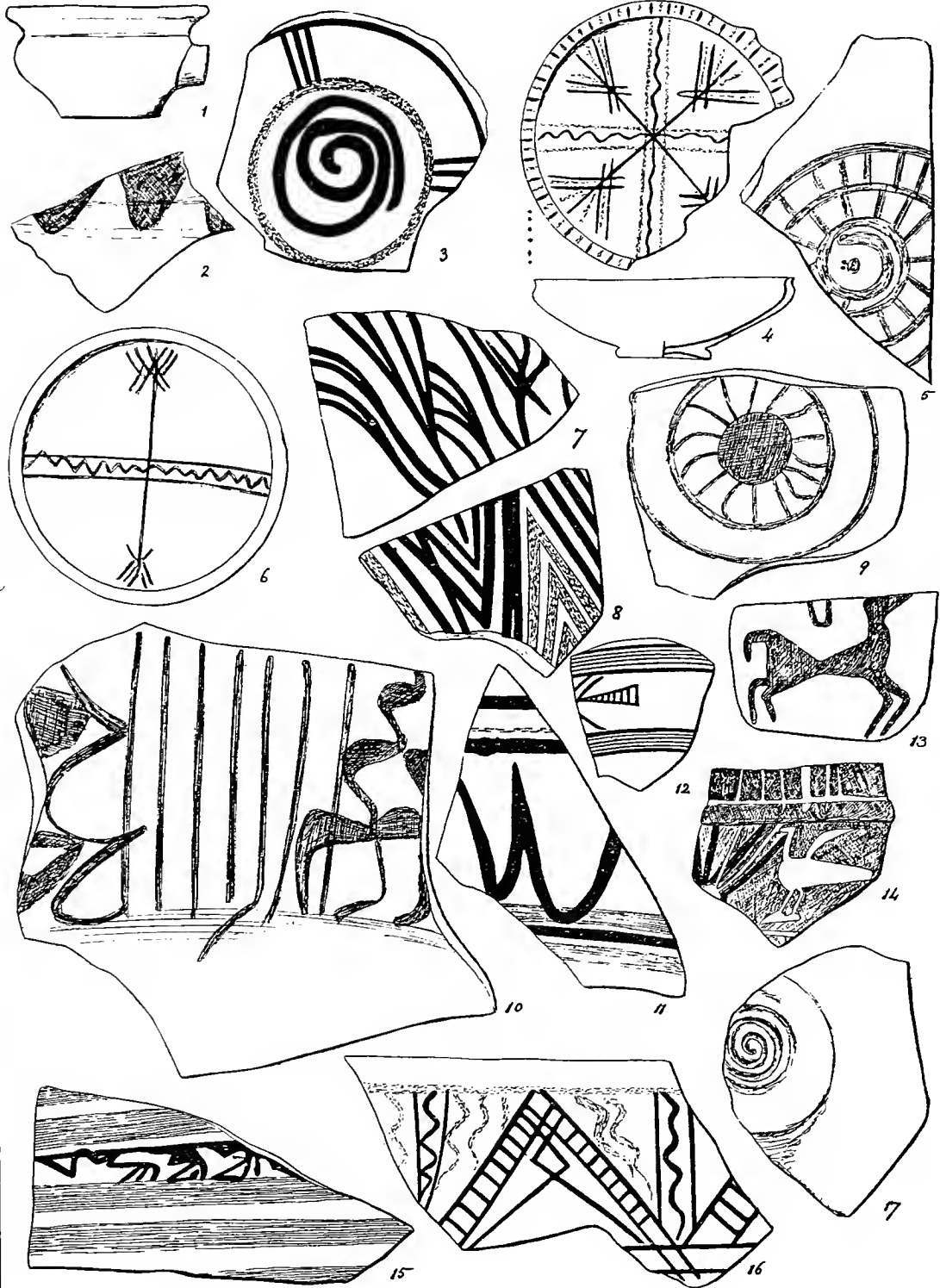

# FOURTH SEMITIC POTTERY

1 in 0 1 2 3 cm 0 1 2 3 4 5 6

figs 6, 10, 12, 13, 15, 16, 19 double scale: fig 8 to 1 1/2









# FOURTH SEMITIC POTTERY

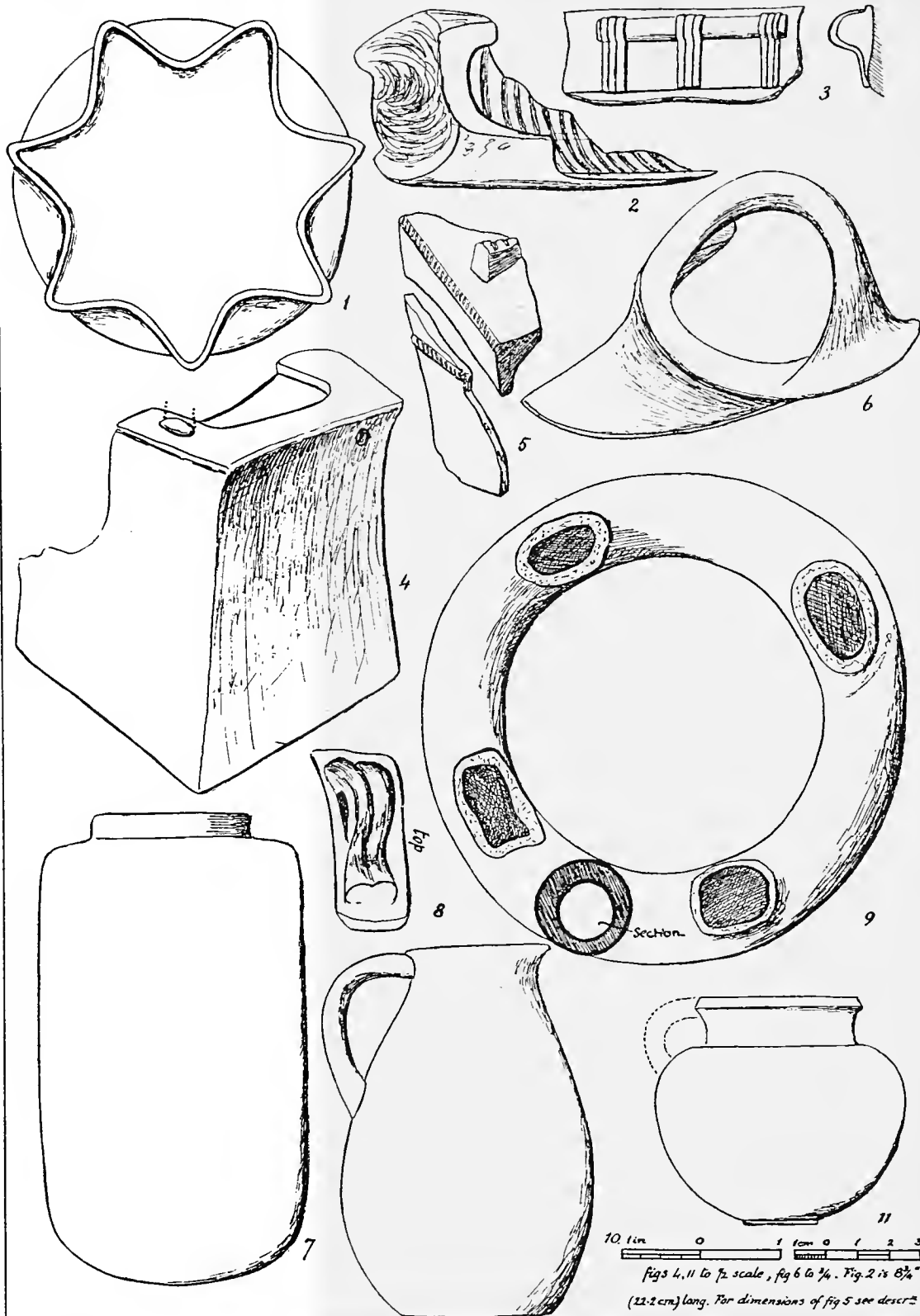

10. cm 0 1 2 3

figs 4, 11 to 1/2 scale, fig 6 to 1/4. Fig. 2 is 8 3/4" (22.2 cm) long. For dimensions of fig 5 see descr. 2

# FOURTH SEMITIC POTTERY

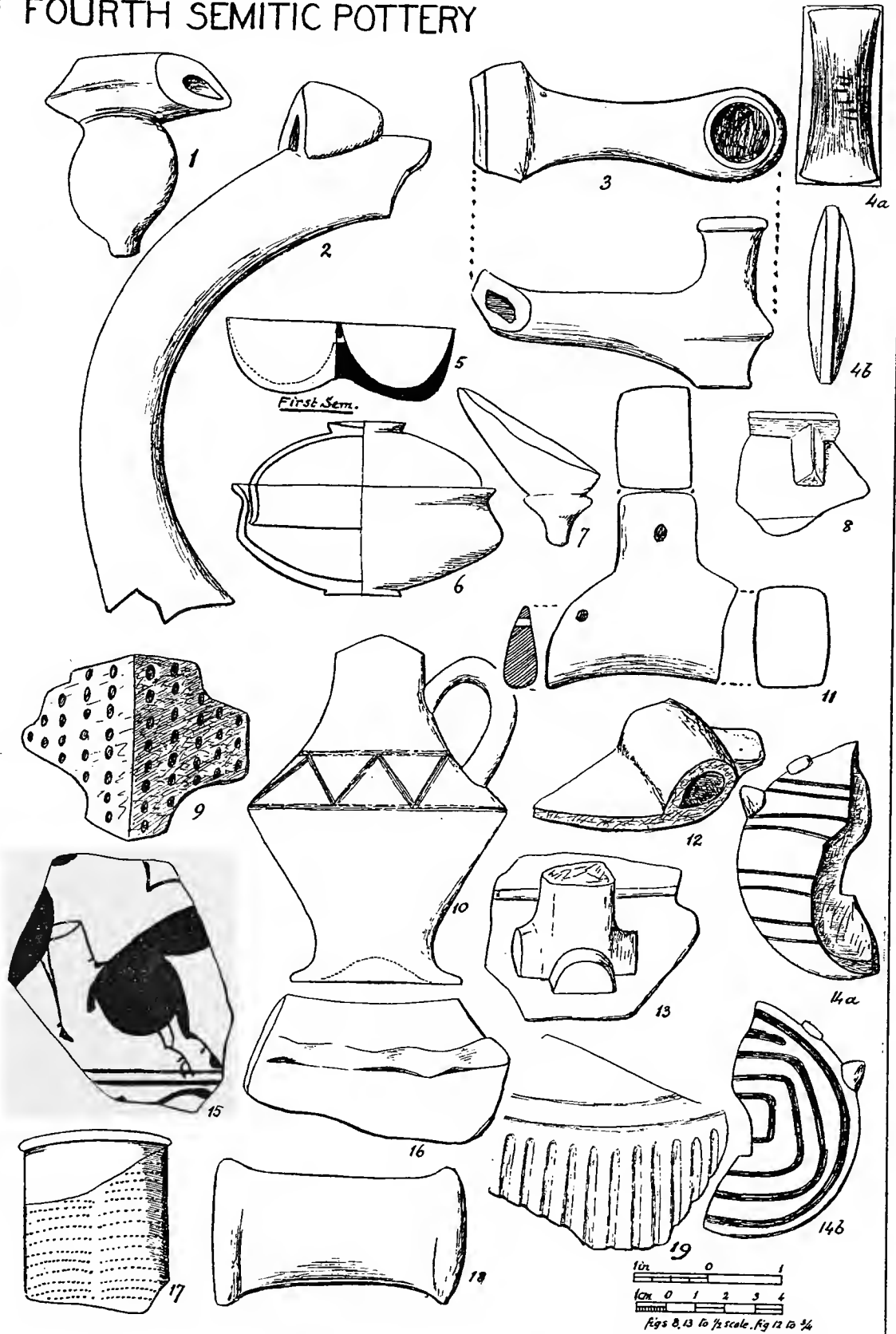





GREEK POTSDHERDS

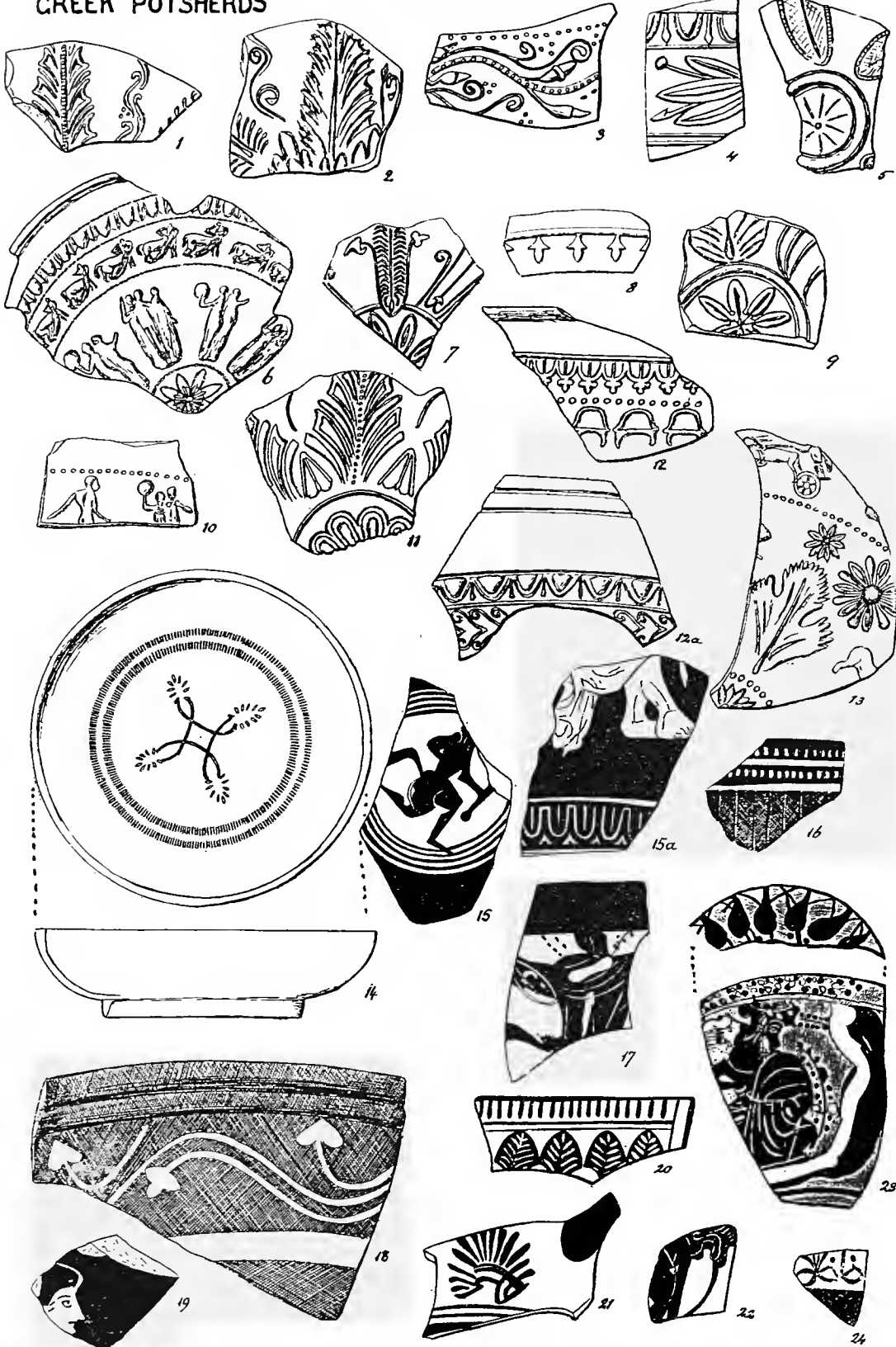
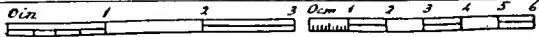

# HELLENISTIC POTTERY

1 cm 0 1  
1 cm 0 1 2 3  
figs. 4, 11, 12, 15 to 1/2 scale

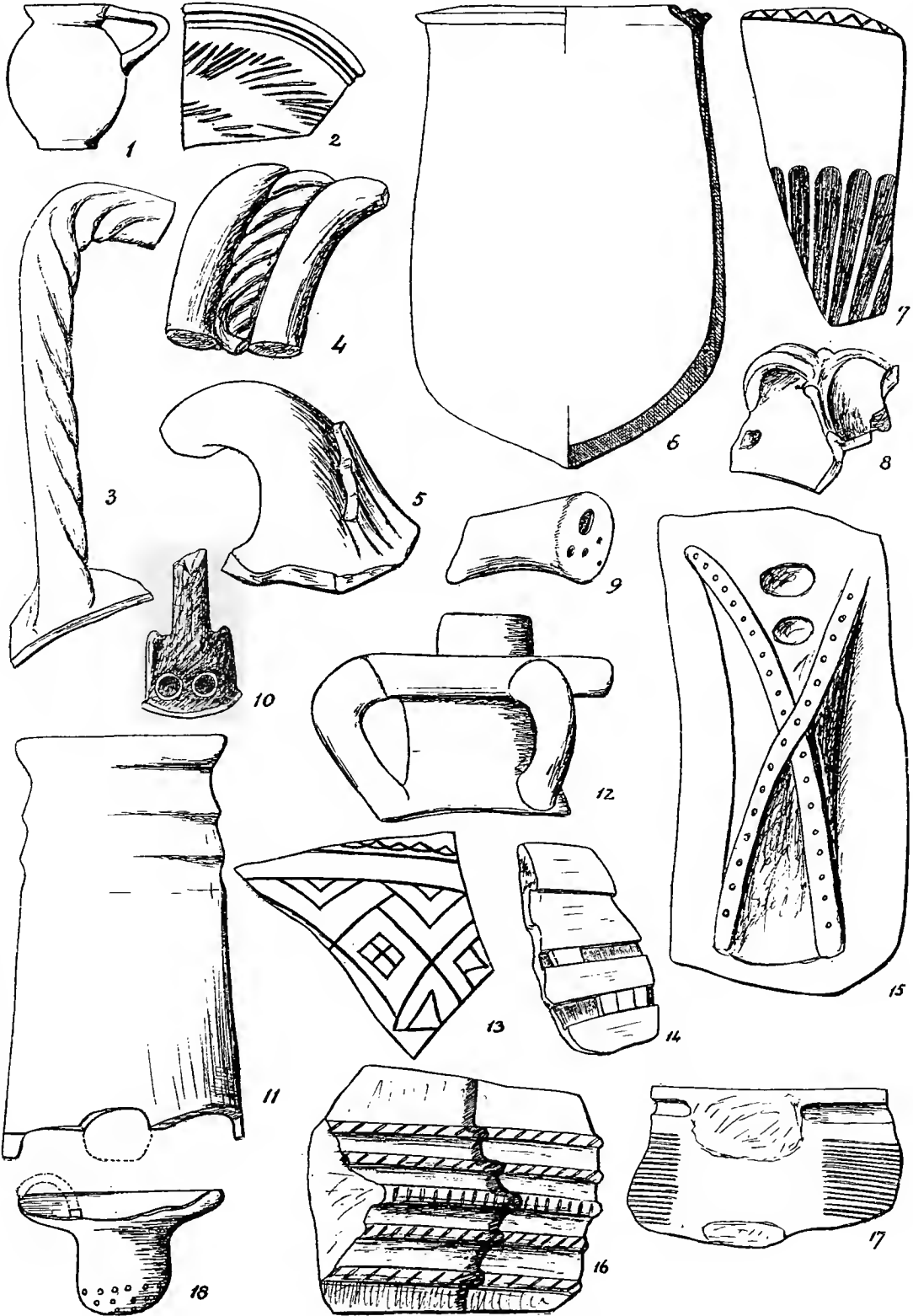







# HELLENISTIC POTTERY

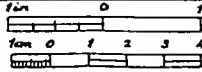

Figs. 1, 12, 13, 15, 16, 17, 21, 25 to 30, 29 to 34

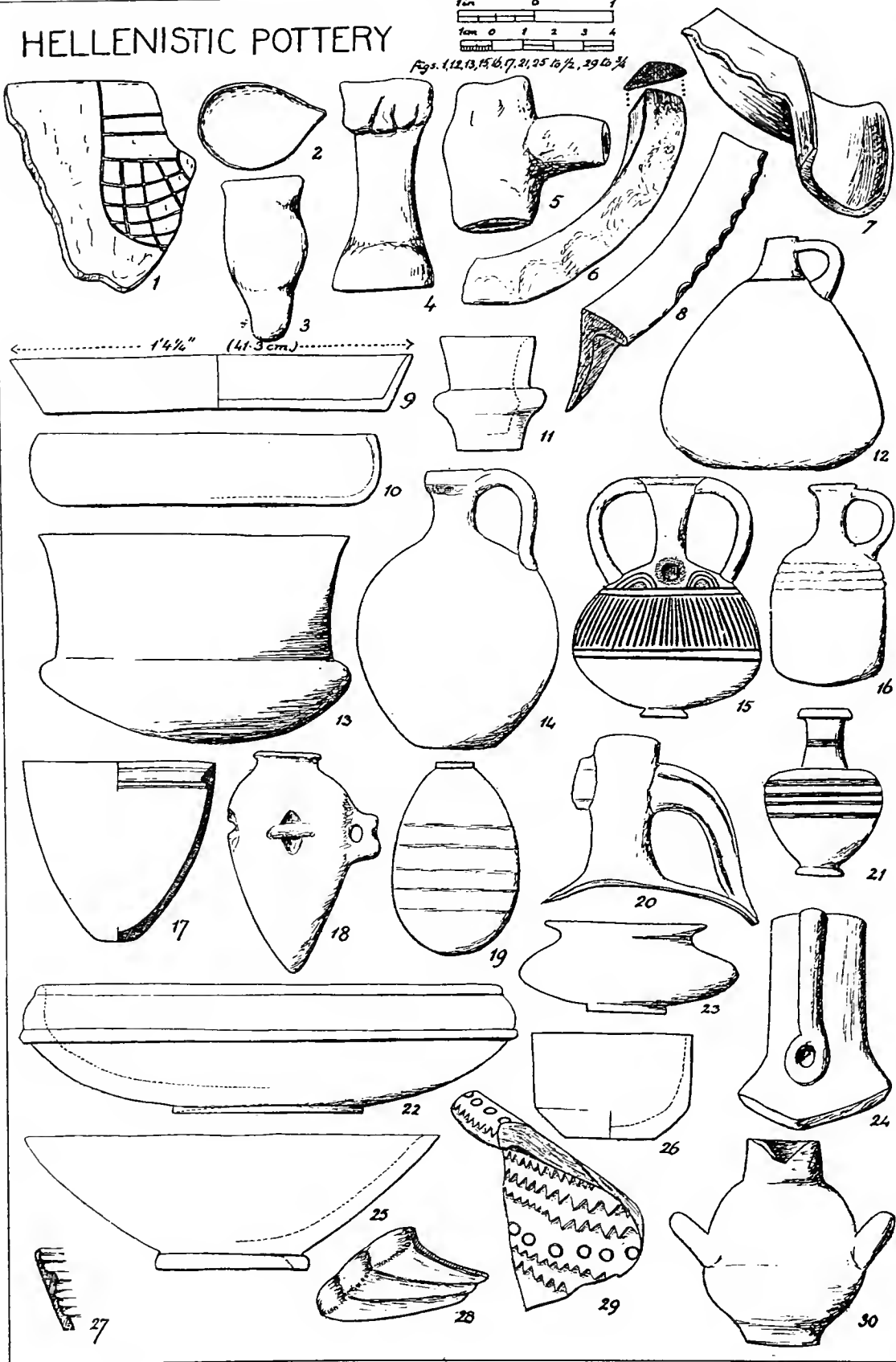

HELLENISTIC POTTERY

0cm 1 2 3 4 5

0in 1 2

*figs 1, 2, 5 to half scale*

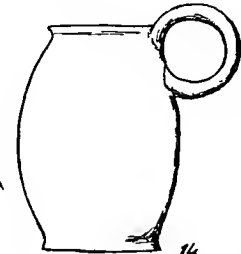
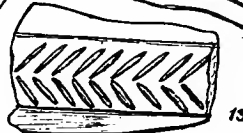
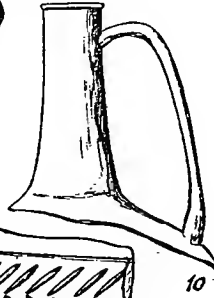
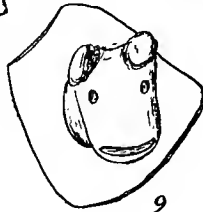
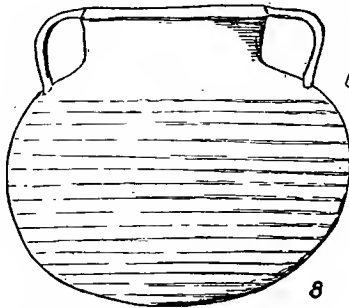
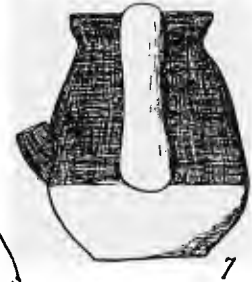
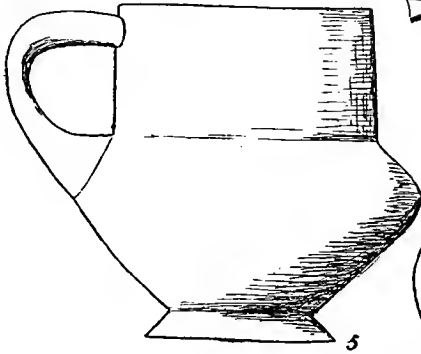
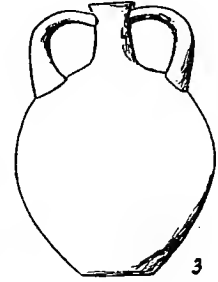
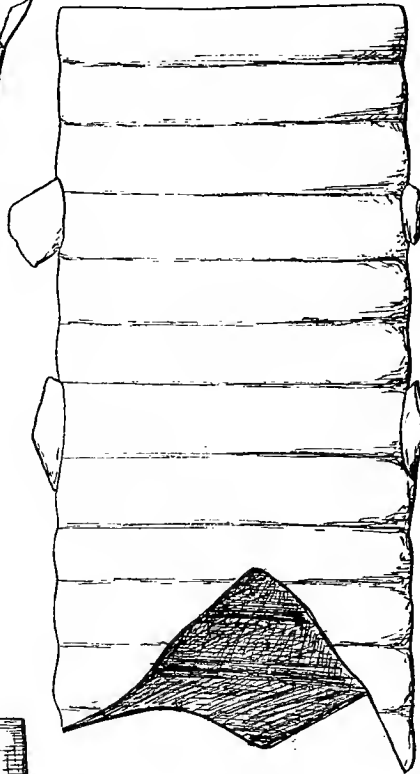





# HELLENISTIC POTTERY

Scale a  
- b

Decm 1	2	3	4	5
Decm 2	4	6	8	10

cm

0 in  
0 in

1	2	3	4
1	2	3	4

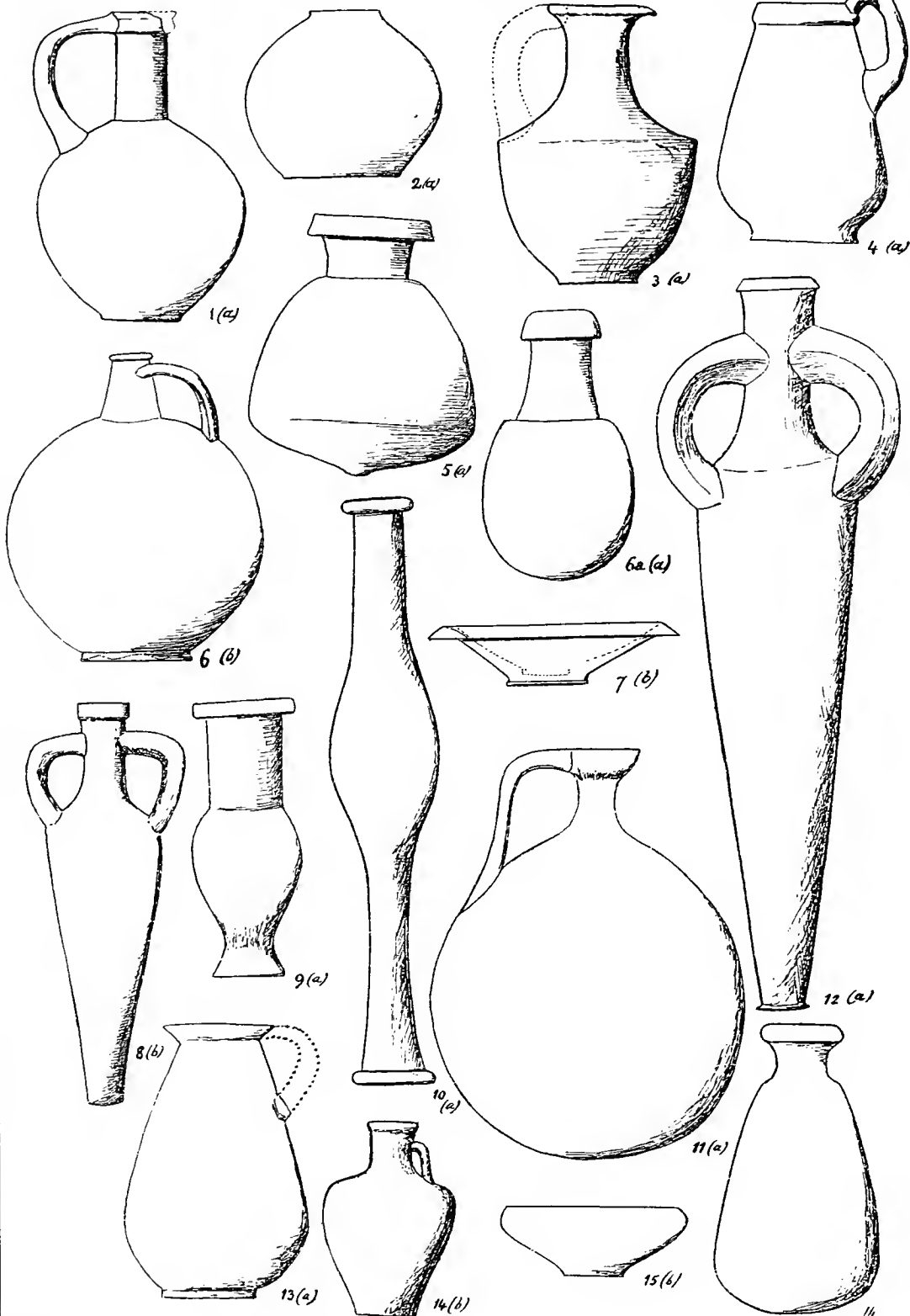

HELLENISTIC POTTERY

0cm 1 2 3 4 5 fig. 1 to 1/2      0in 1 2

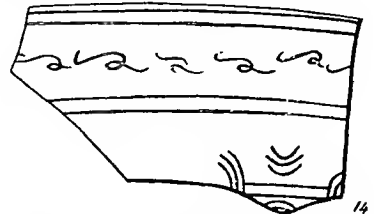
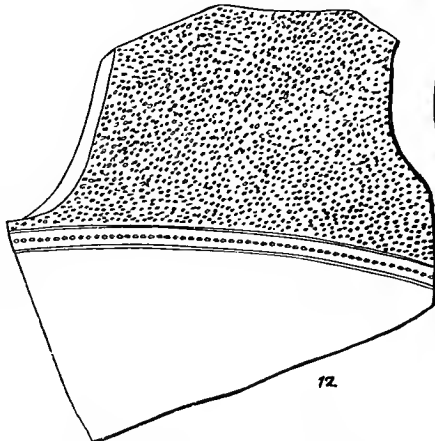
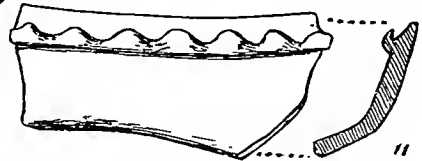
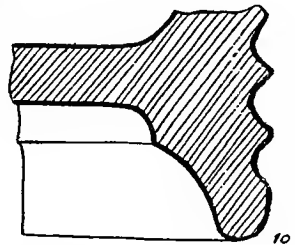
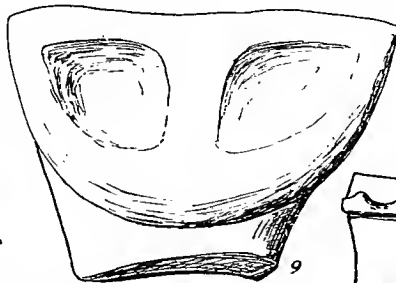
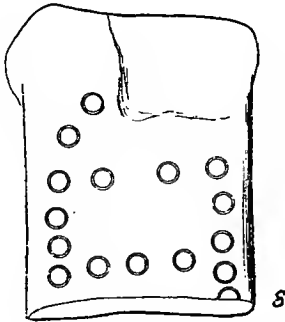
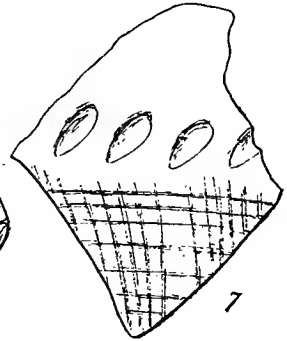
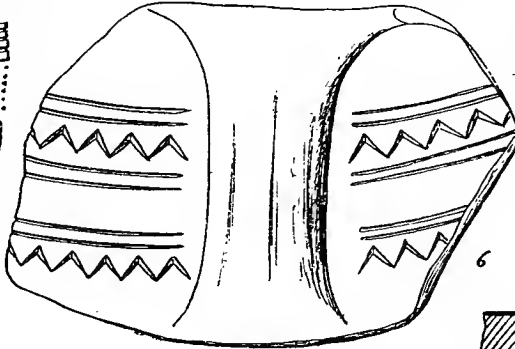
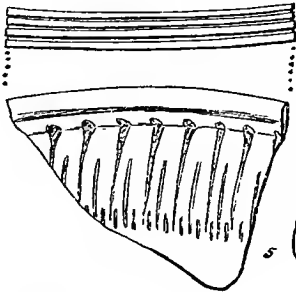
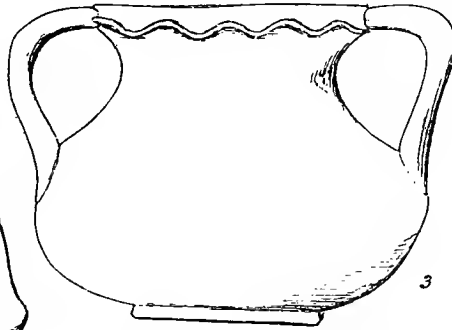
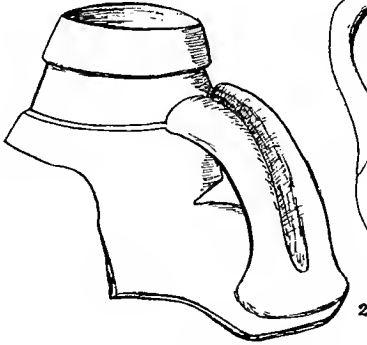







# HELLENISTIC POTTERY

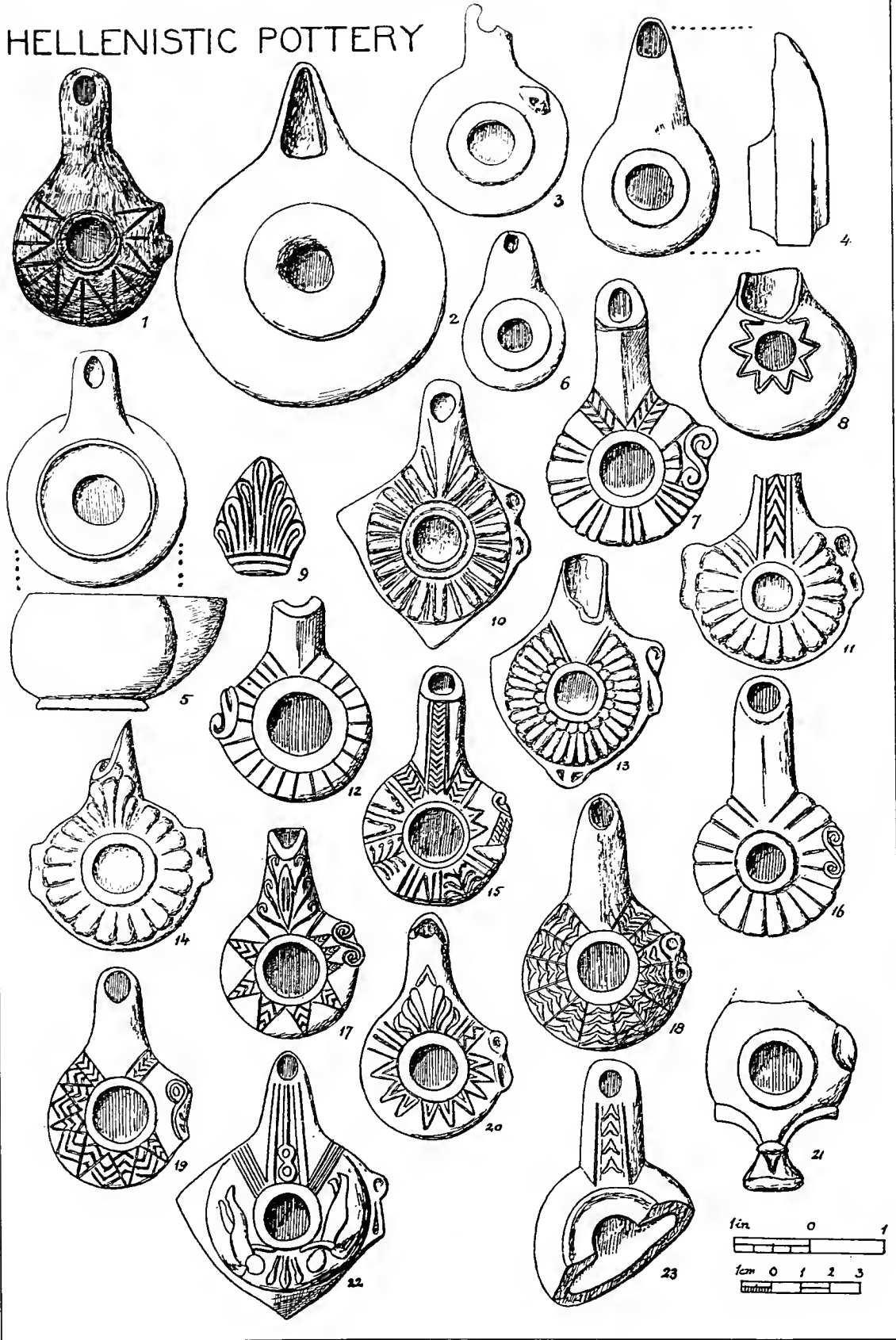

# HELLENISTIC POTTERY

figs. 4, 6, 8, 9, 10 to double scale.  
0 cm. 2 4 6 8 10      0 in. 1 2 3 4

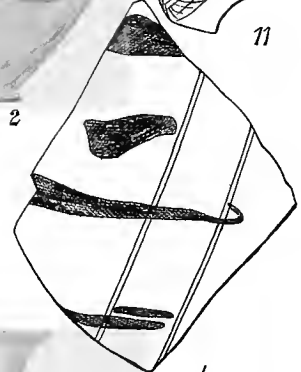
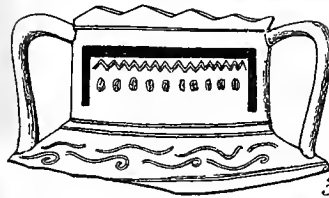
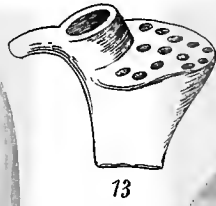

section of handle  
fig. 7.

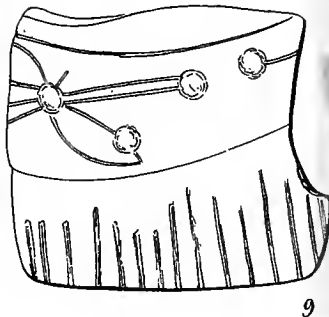
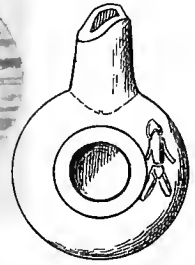



CONTENTS OF CISTERN IN IV 11

*figs. 10-16 double size*

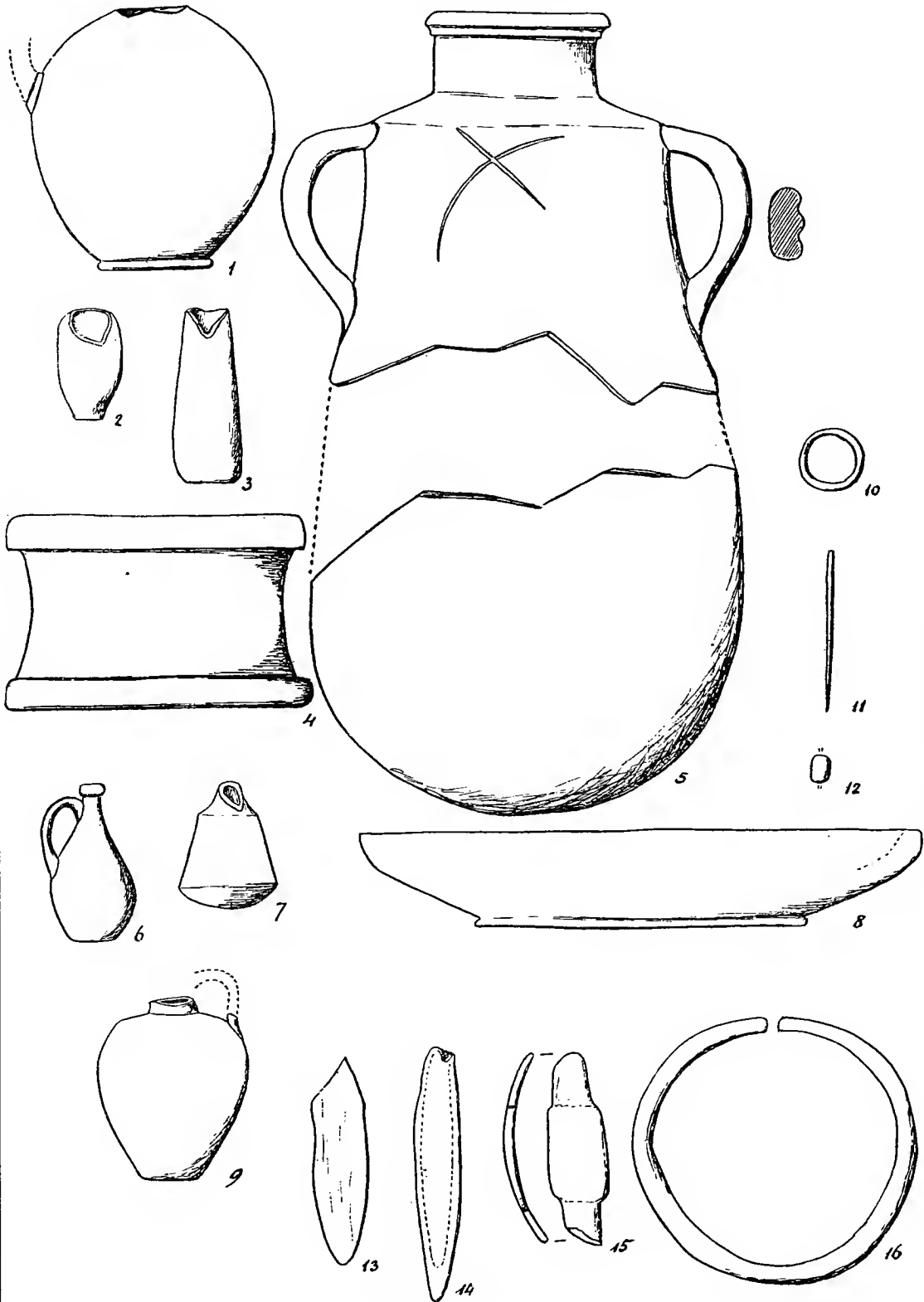
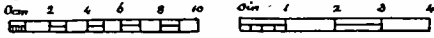







CONTENTS OF CISTERN IN IV11

*Figs. 6, 7, 9, to double scale*  
0cm 1 2 3 4      0in 1 2 3 4

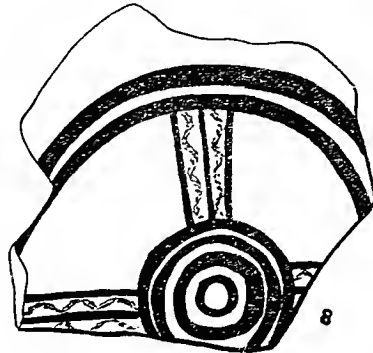
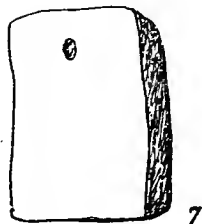
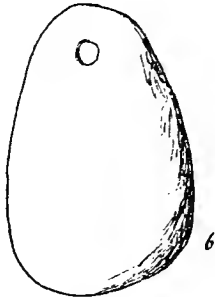
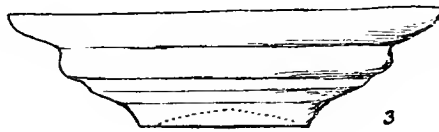
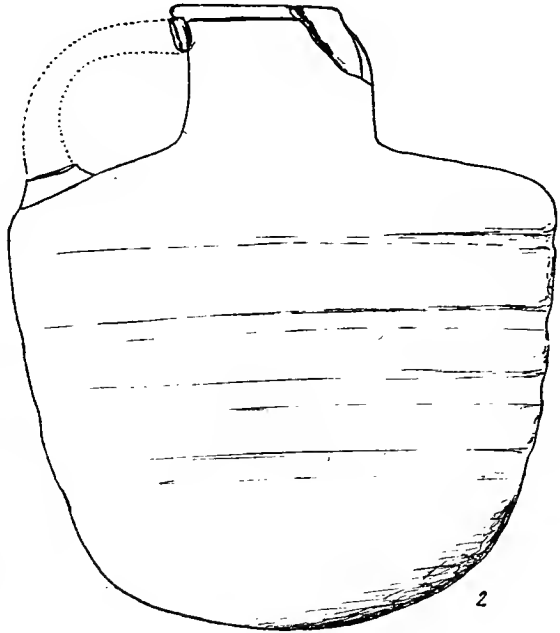
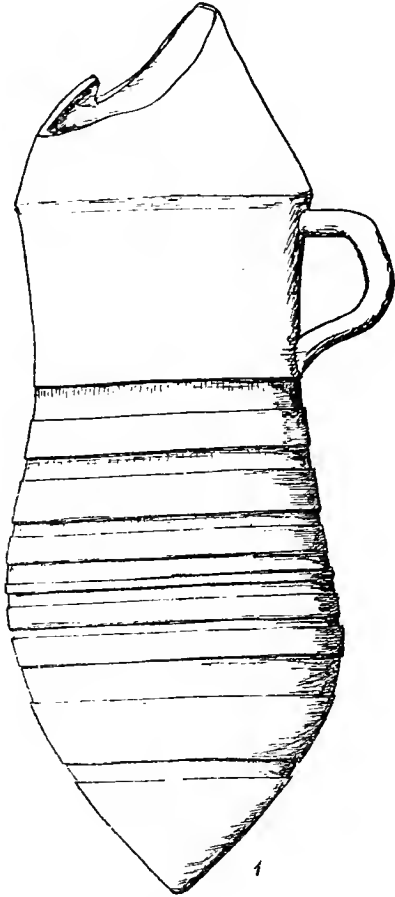

CONTENTS OF CISTERN IN IV 11

*figs. 17, 18, 20, 22, 24, 25 to double scale.*

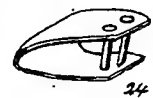
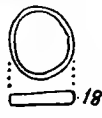
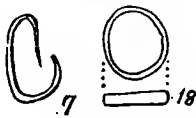
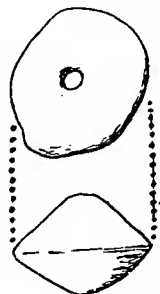
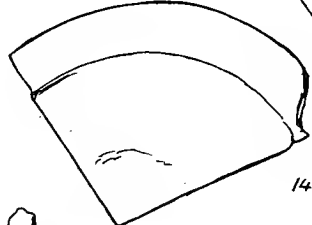
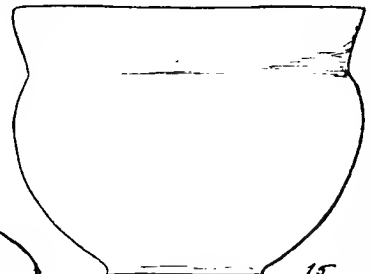
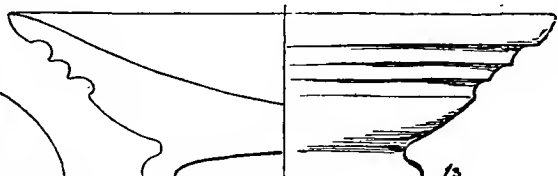
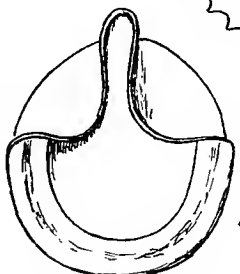
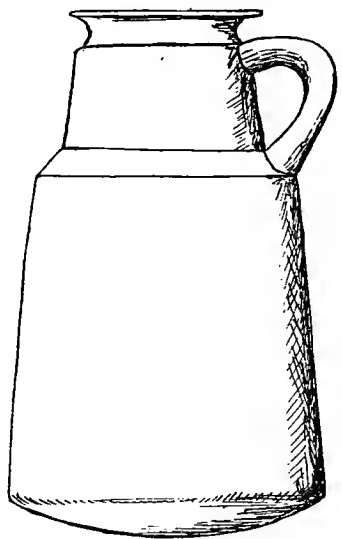
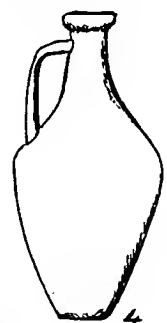
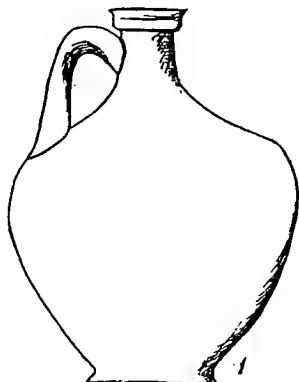
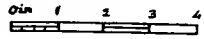
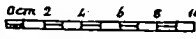





THE "CANDLESTICK" LAMP  
AND ITS VARIETIES

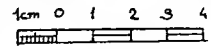
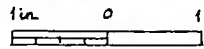
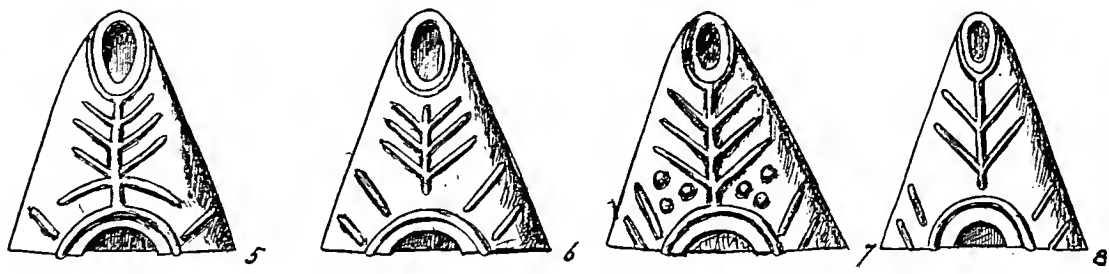
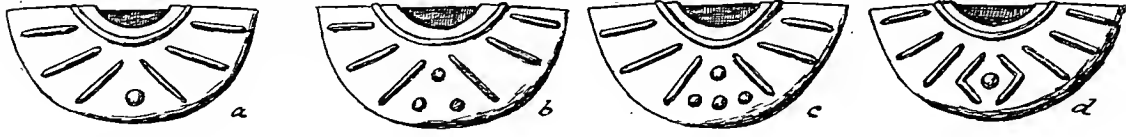
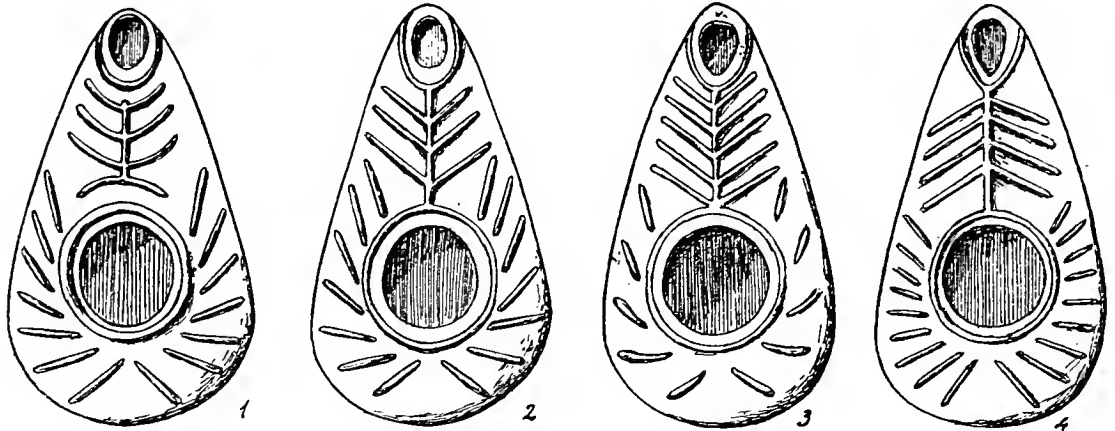

ARAB POTTERY &c.



figs. 26-36 to double scale

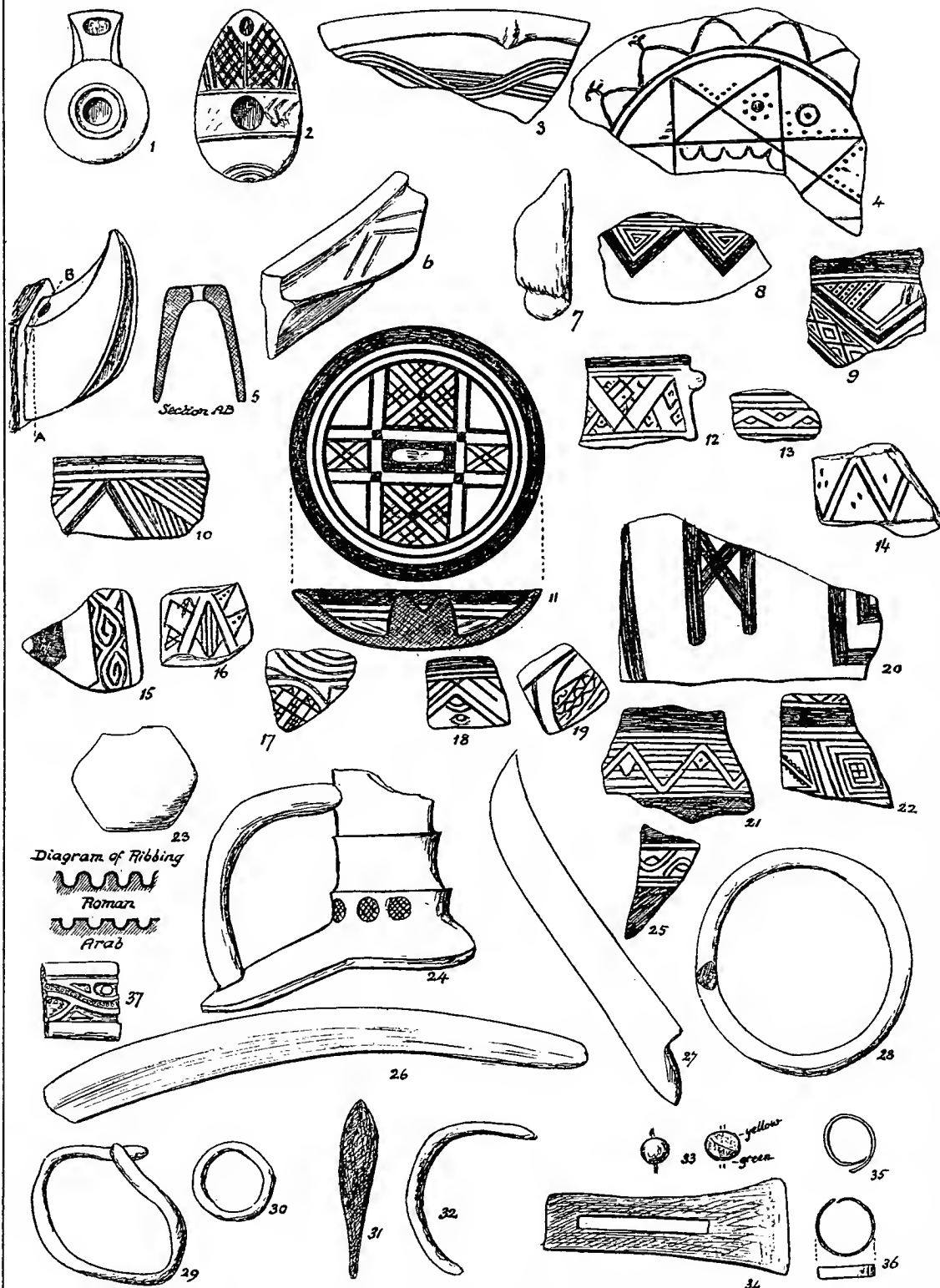







# POTTERS' MARKS



# JAR-STOPPERS

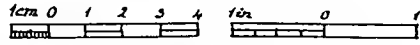
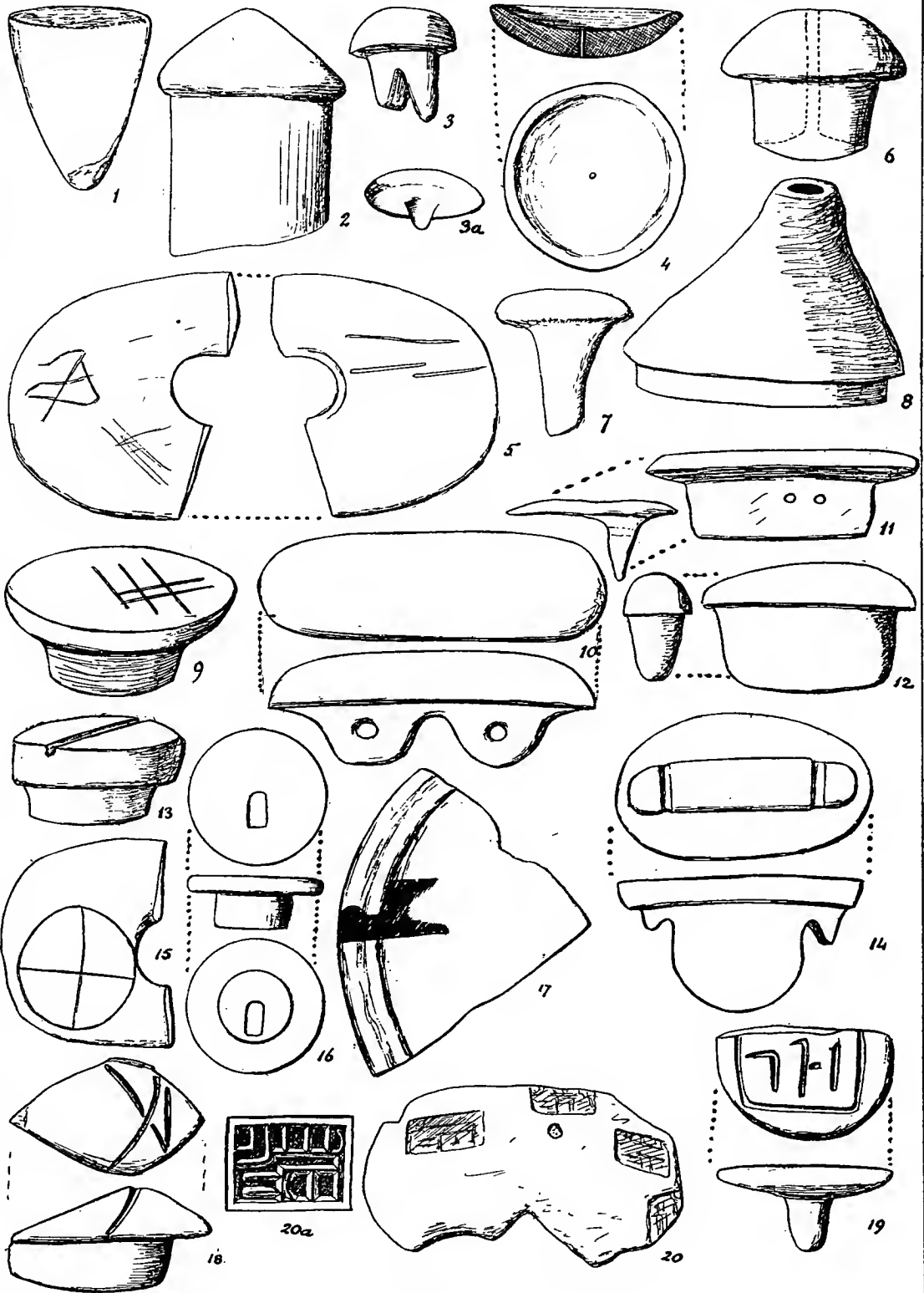

fig. 1 to half scale







# BRONZE AXE-HEADS

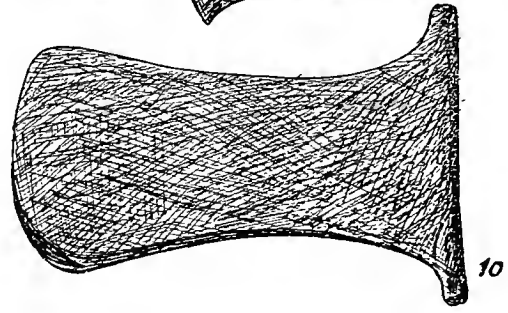
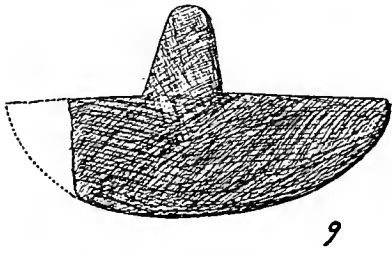
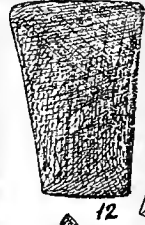
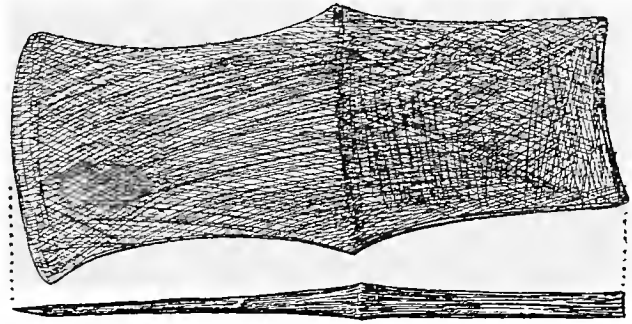
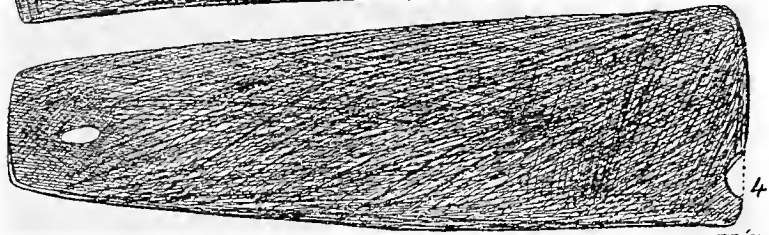
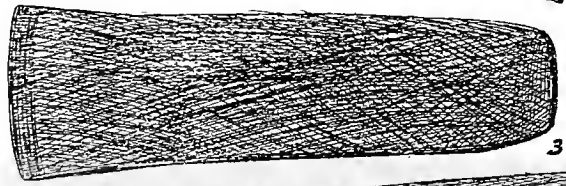
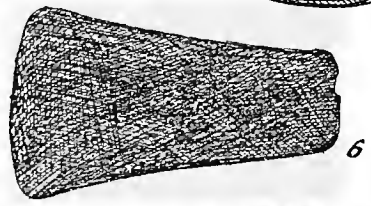
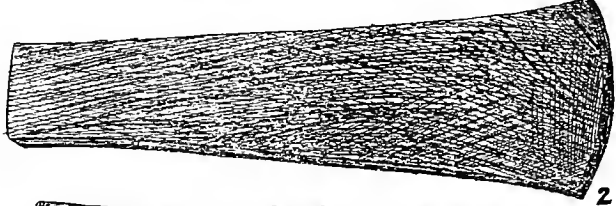
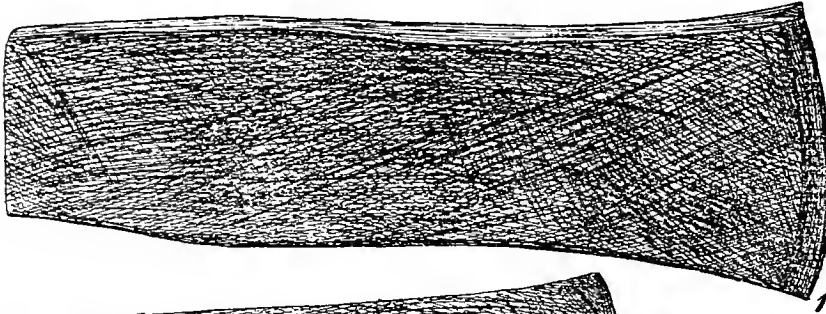
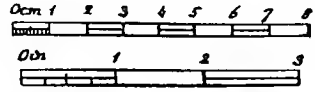

CARPENTERS' TOOLS

Figs. 2, 11, to half scale

0cm 1 2 3 4 5

0in 1 2

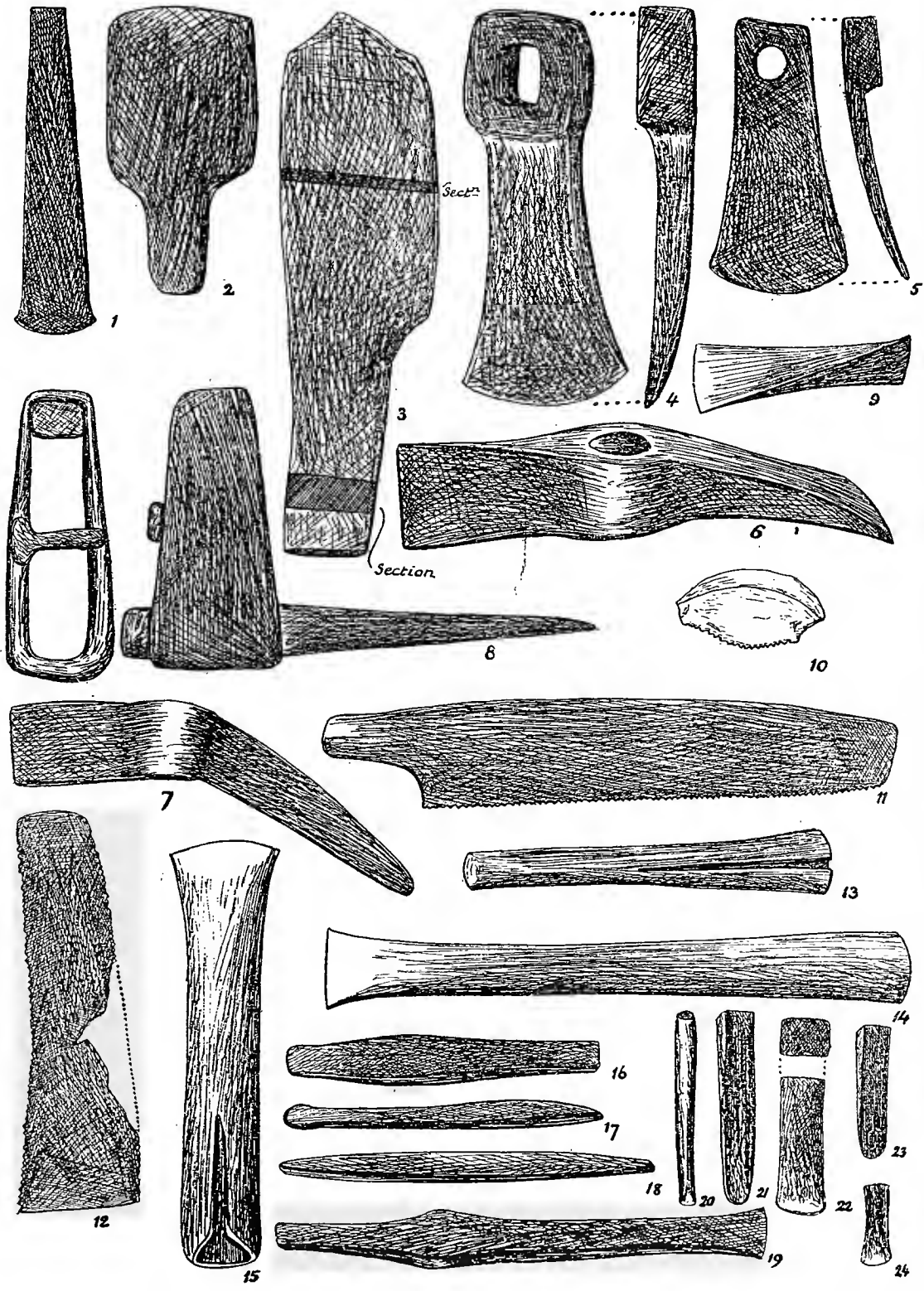







# CARPENTERS' TOOLS

0cm 1 2 3 4 5 6

0in 2

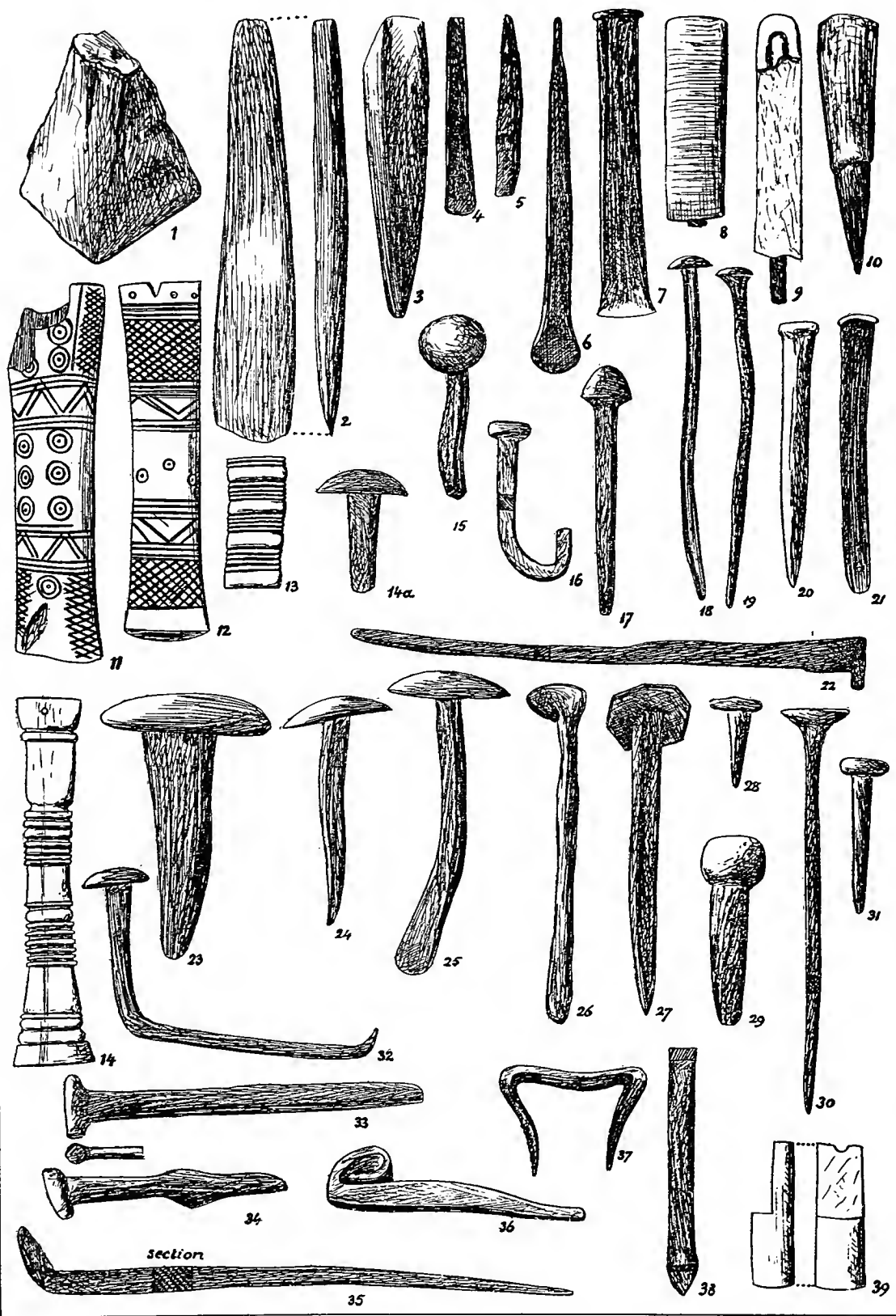

# INLAYS

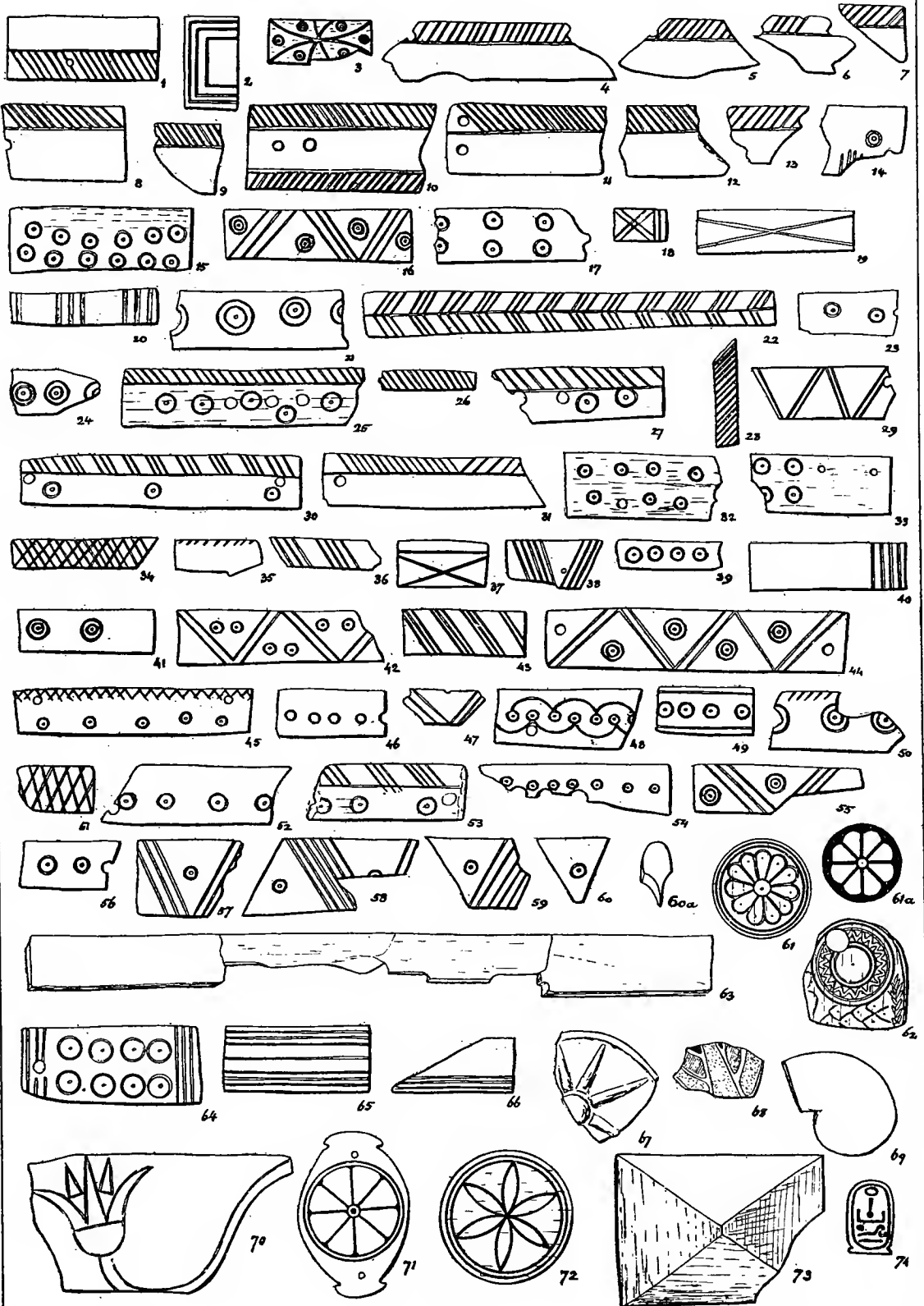
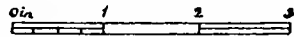
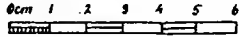





STONE MISCELLANEA



*figs 2, 5, 14, 15, 19 to half scale*

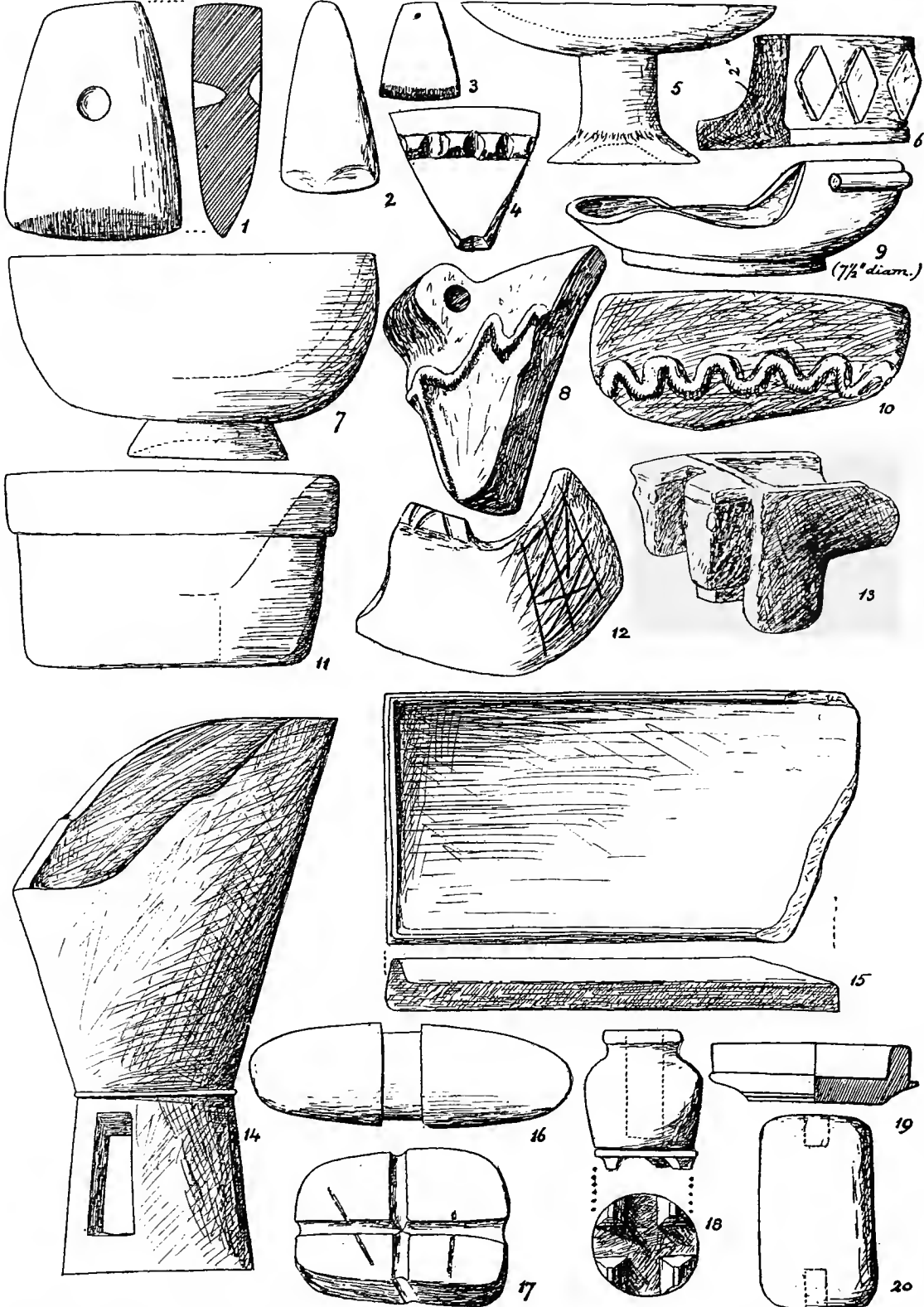

METAL MISCELLANEA (1-27 BRONZE 28-41 IRON)

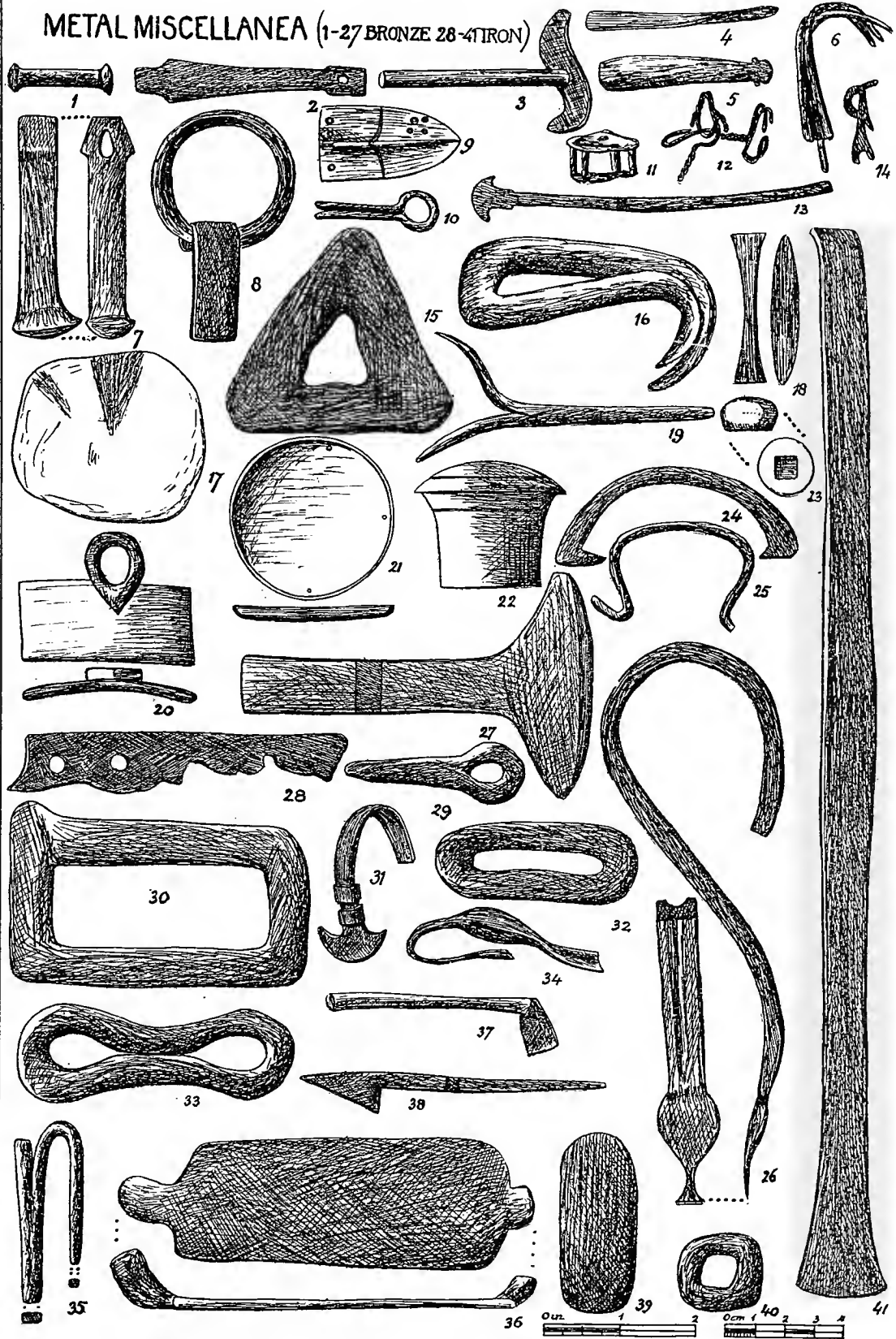







# KNIVES (BRONZE)

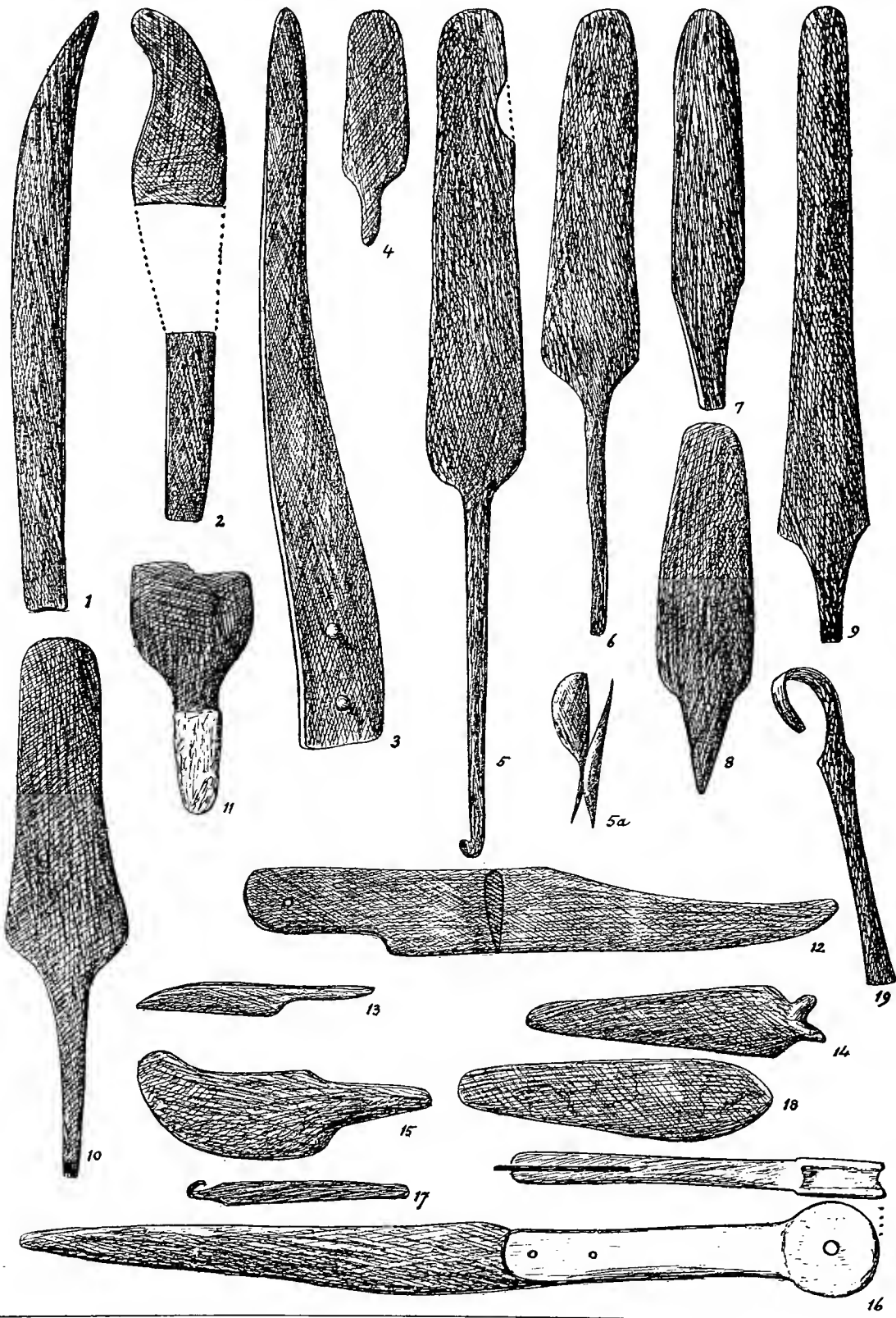
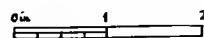
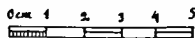

# KNIVES (IRON)

fig 7 to half scale  
0cm 1 2 3 4 5

0cm 1 2

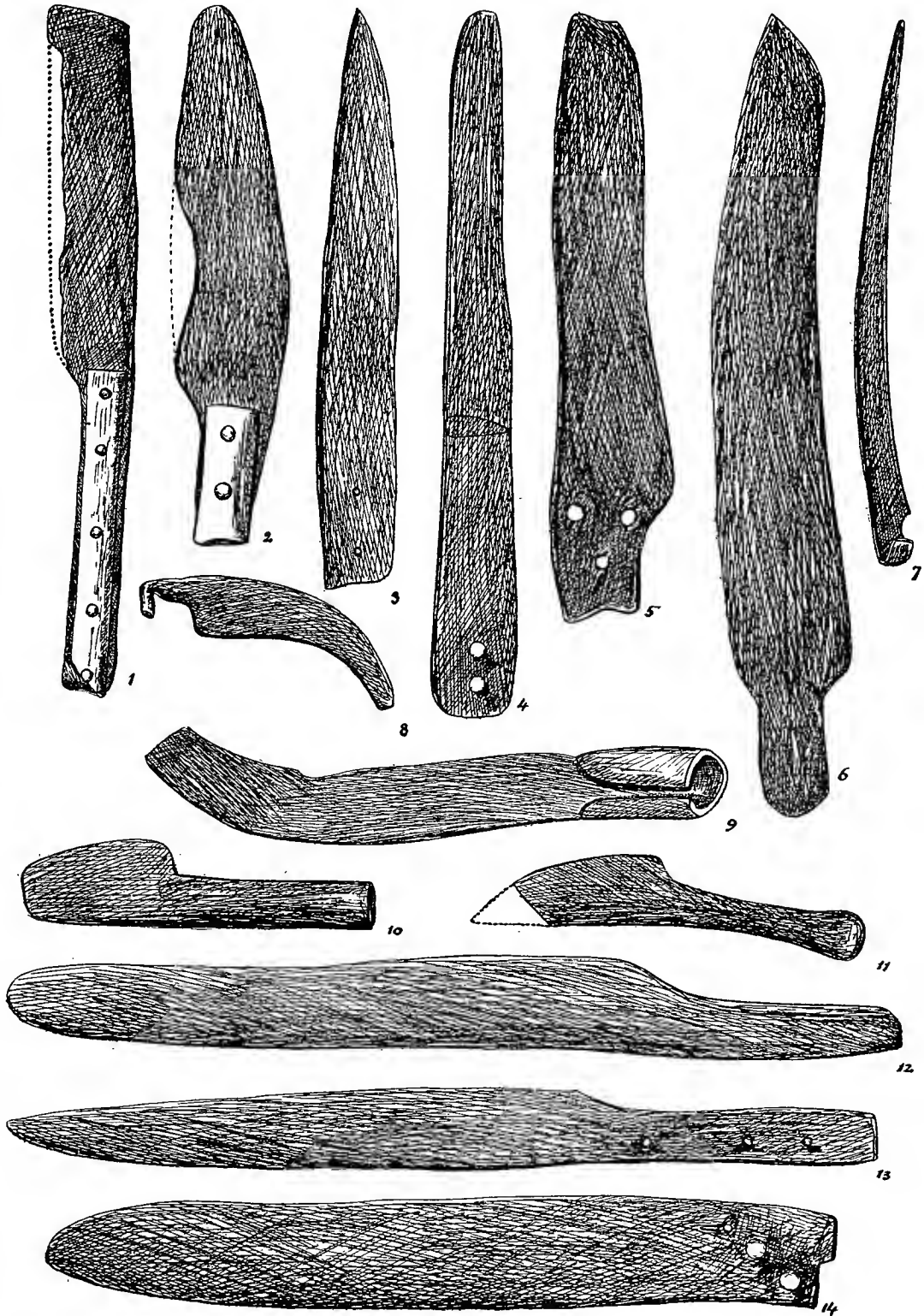





SEALS

Figs. 32-36, 38-48, 50, 51 to half scale  
0 1 2 cm



# DRAUGHT-BOARDS

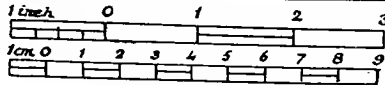

figs 1,4,6,8,9 to half scale

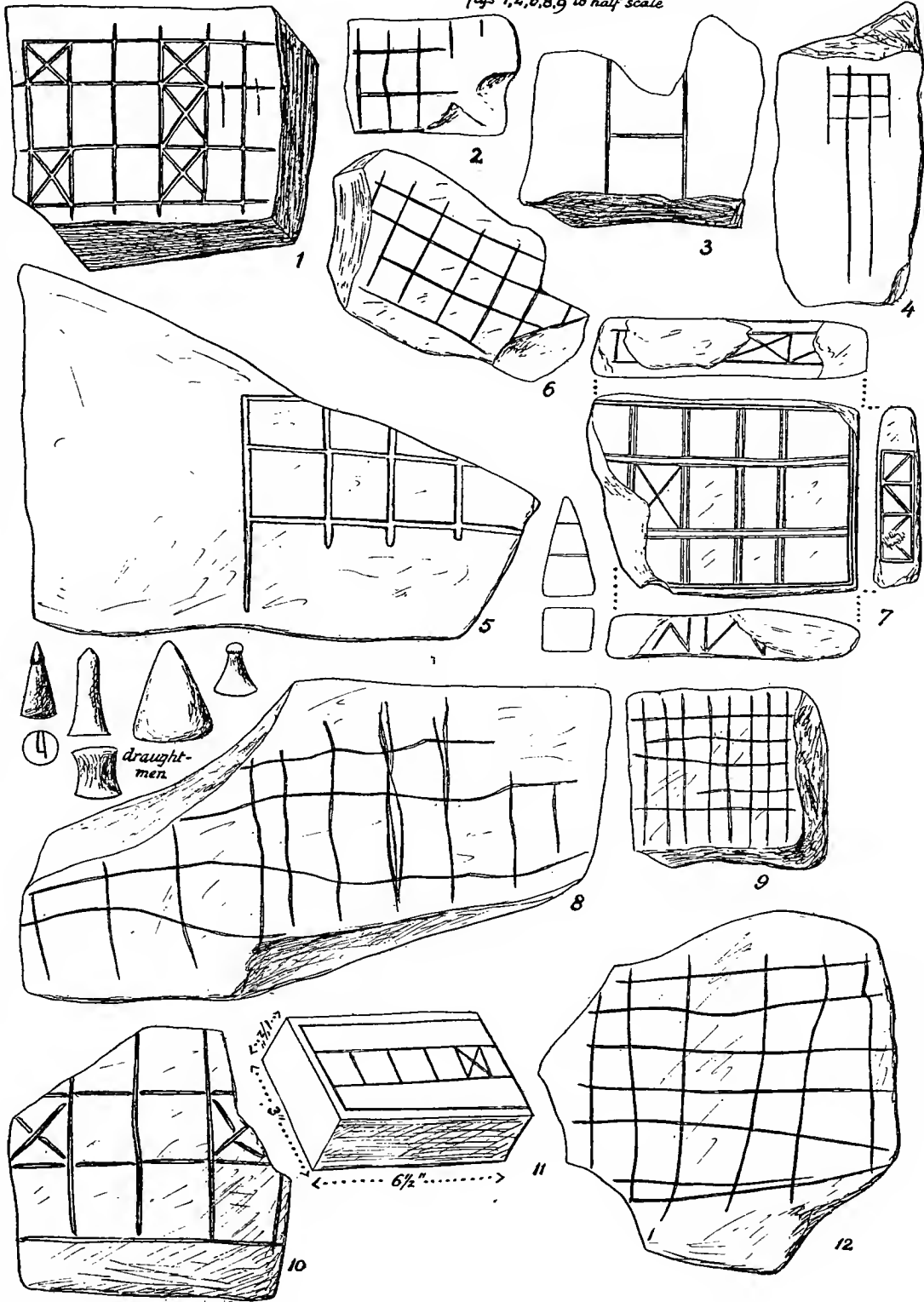







Plate ccii a

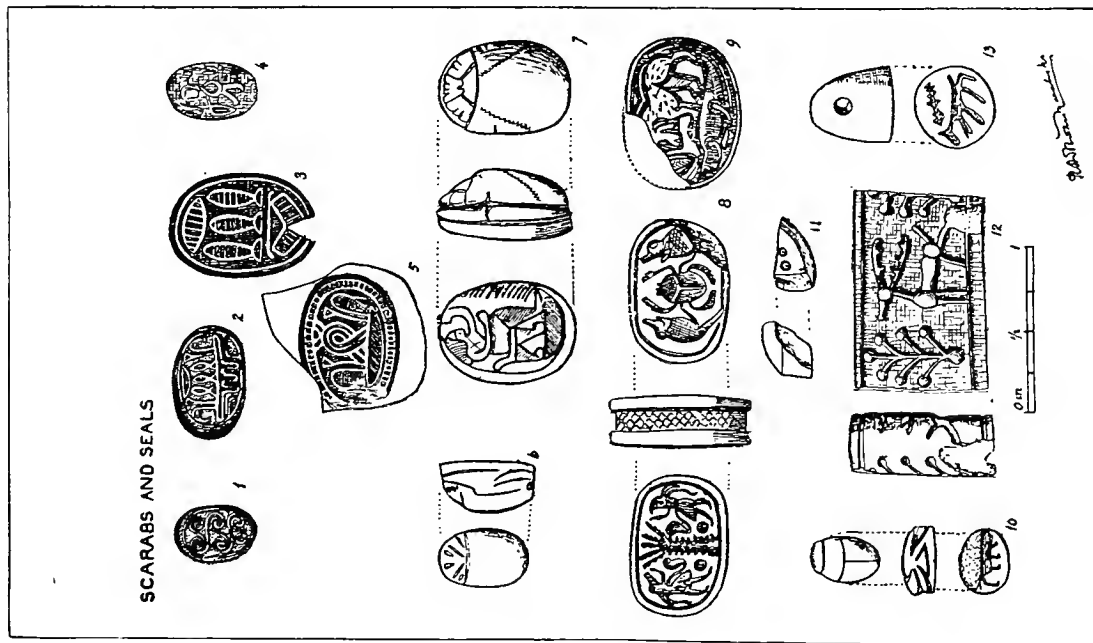
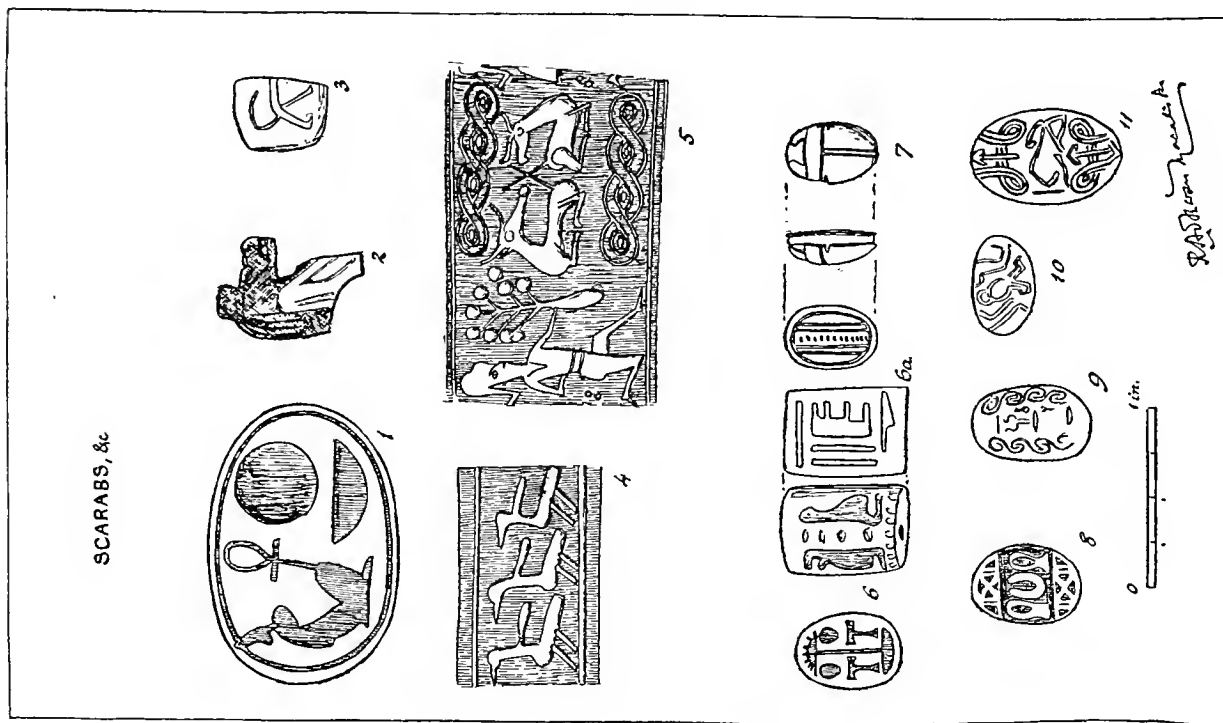

Plate ccii b









SCARABS (1-8) & SCARAB SEALS

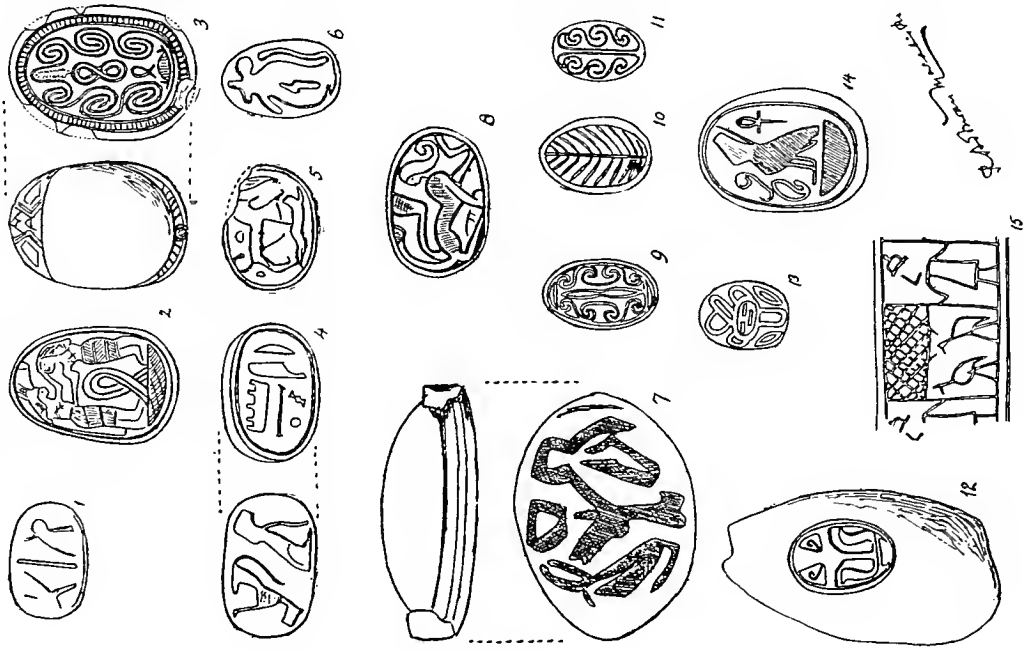
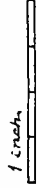

SCARABS

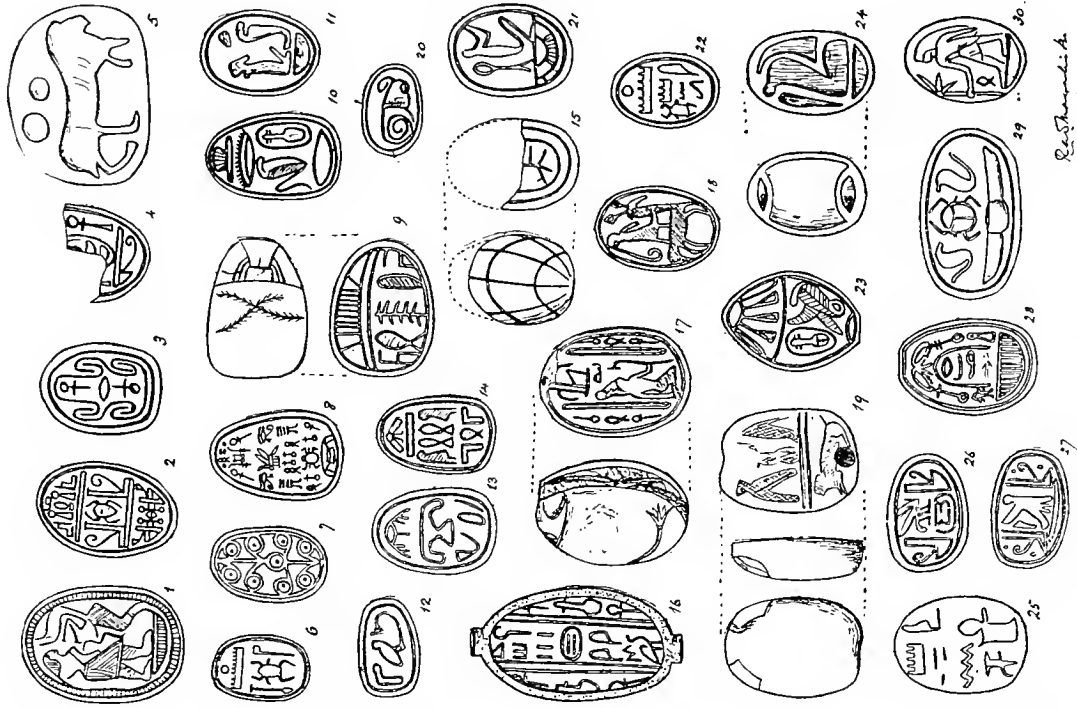

Reisner, A.

PORCELAIN SAUCER

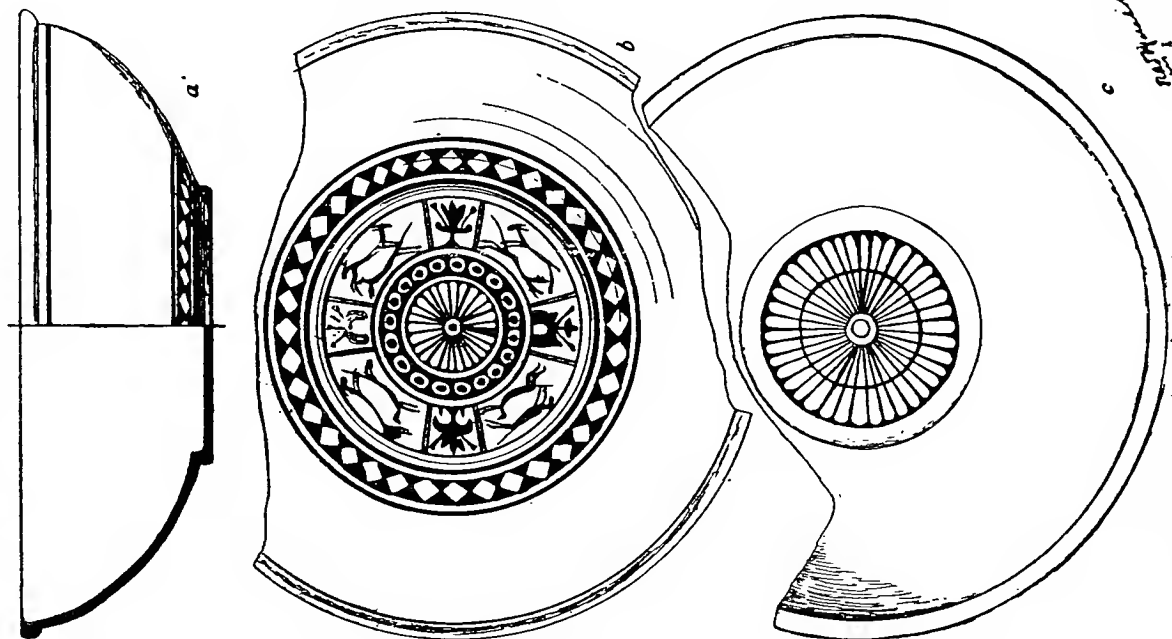

*Brinckman*

SCARABS

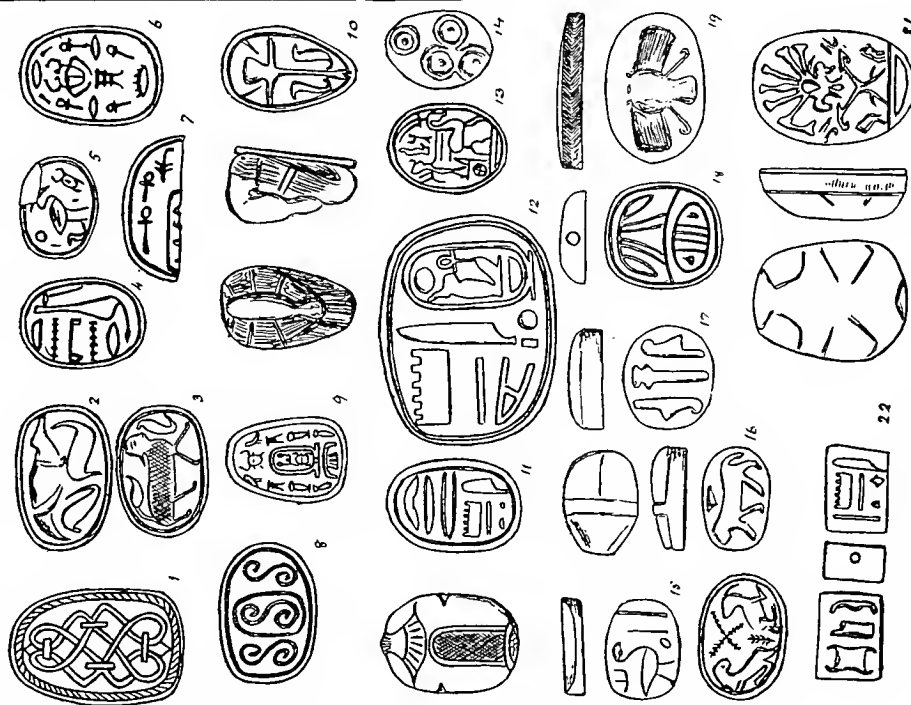

*Reinhardt*







# SCARABS

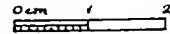
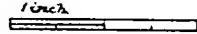

# SCARABS

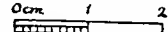
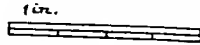

figs 30, 31 to 1/2 scale

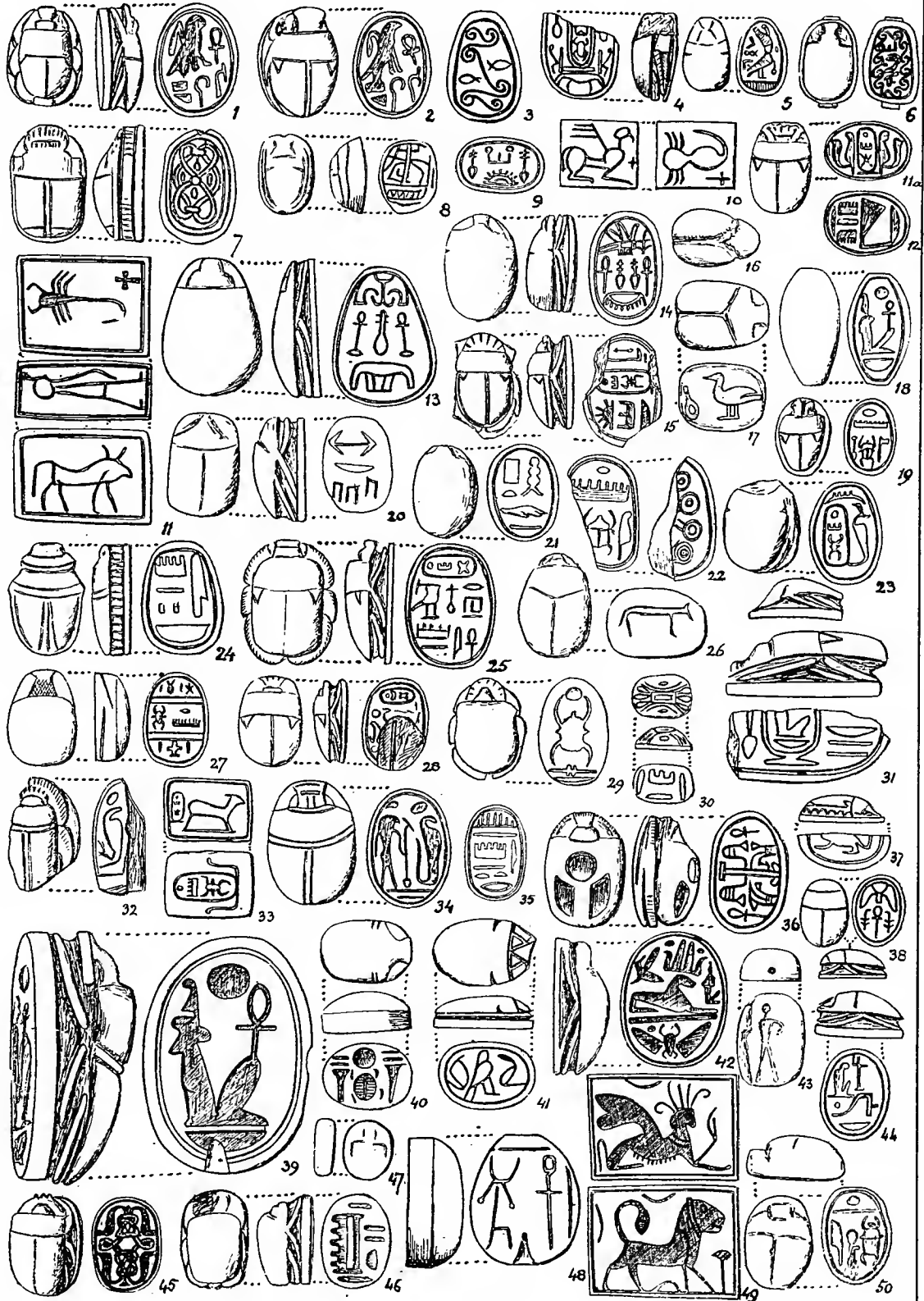





SCARABS



figs 25, 26, 38, 40, 48, 53 to 1/2 scale



# SCARABS &c

0cm 1 2      cm. 2 3 4 5  
figs 1-17 to double scale, fig 95 to 1/2









# EGYPTIAN AMULETS &c

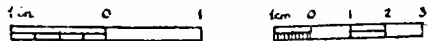

Figs 3, 4, 10, 11, 13, 14, 52, 55 to double scale: 77 to 2 1/2 scale

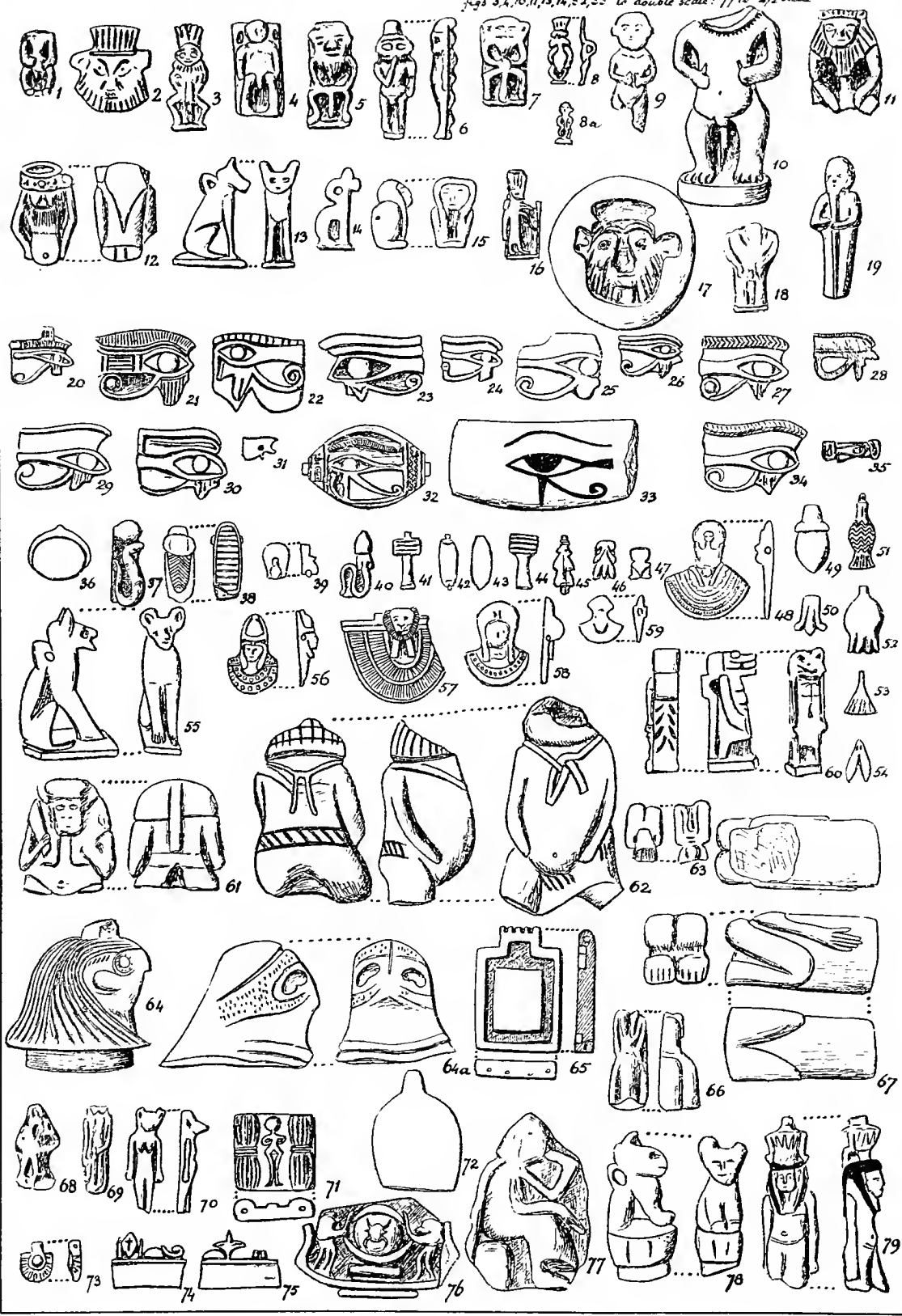

# EGYPTIAN FIGURES & FAÏENCE

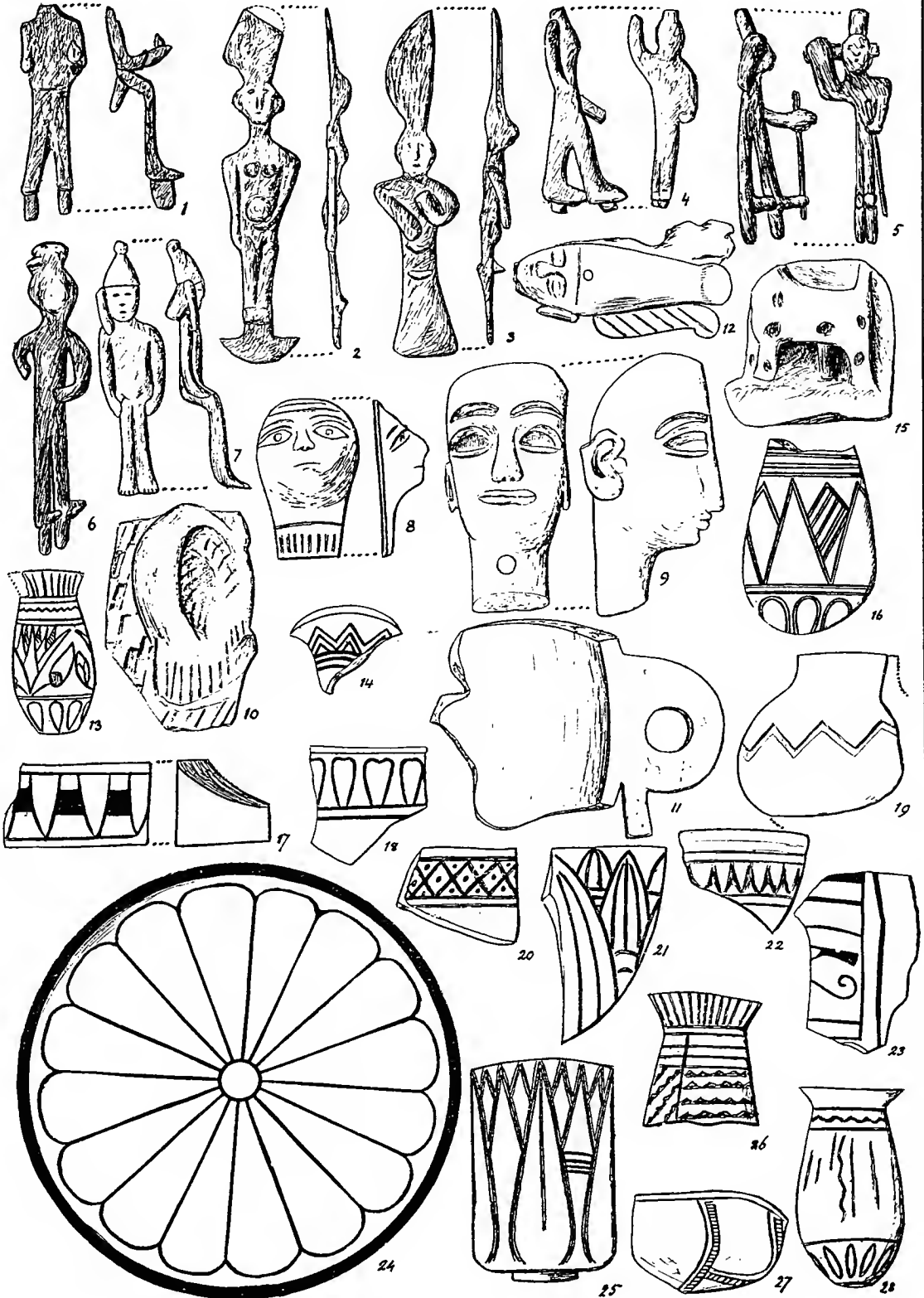
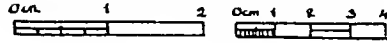





# ALABASTER

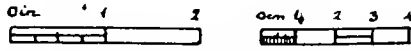

figs 5, 6 to half scale

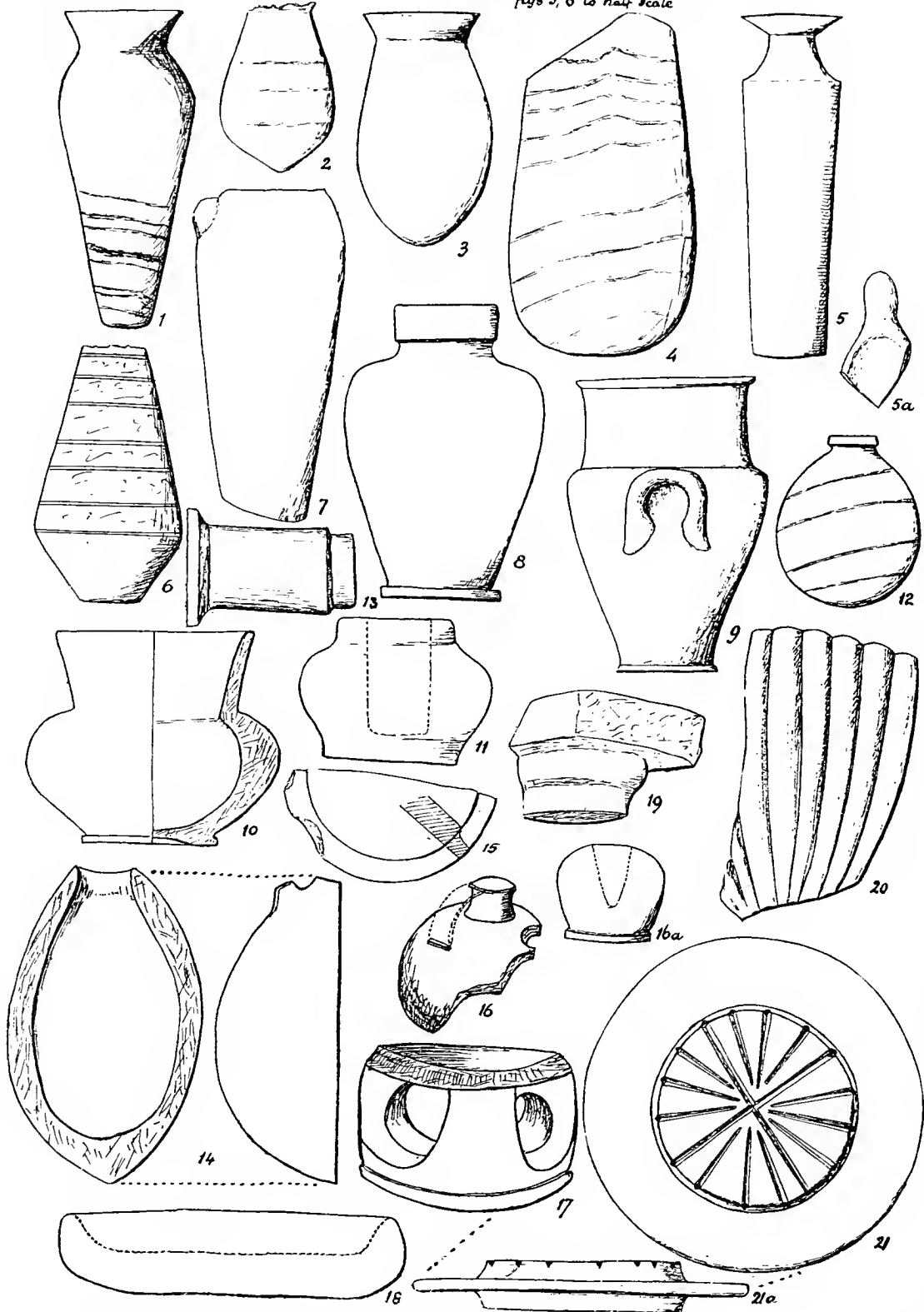

STONE SAUCERS



(dimensions of figs. 11, 19 in *Waterpress*)

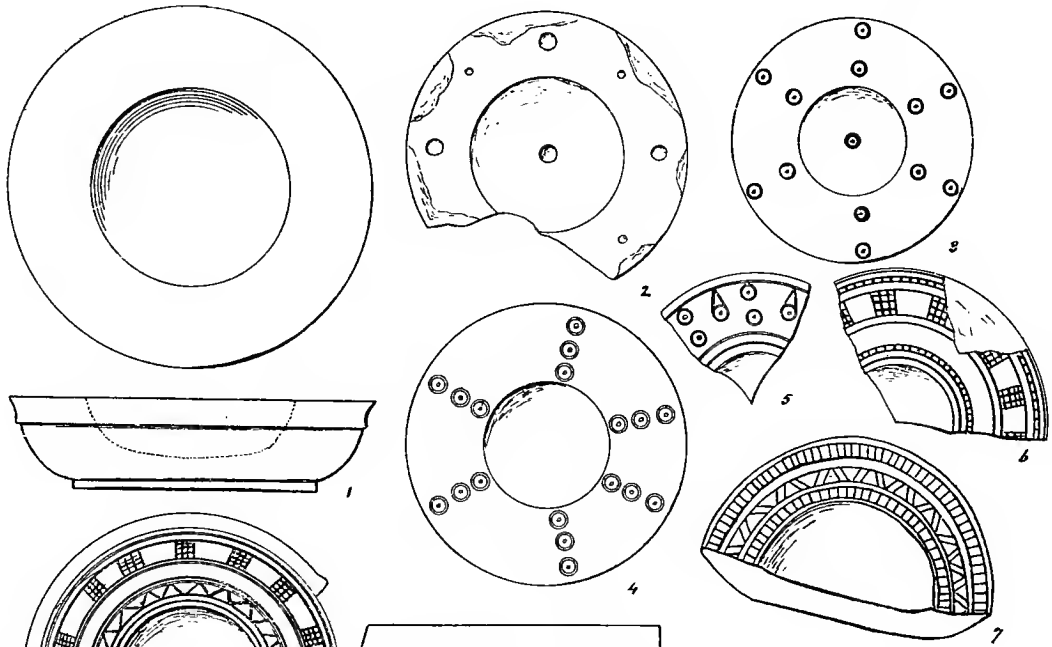

ALABASTER









CYLINDERS &c.

double scale: 4, 7, 8, 11, 14, 9, 23-26, 28

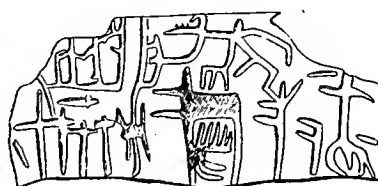
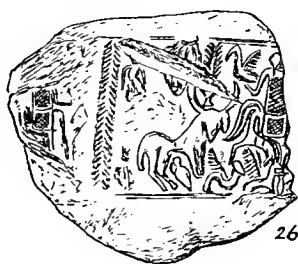
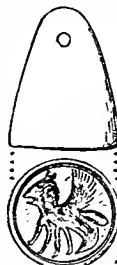
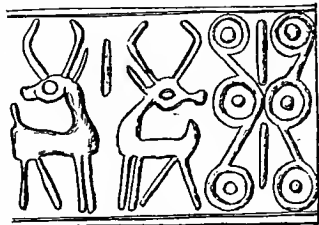
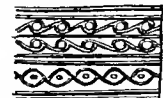
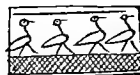
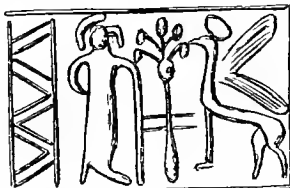
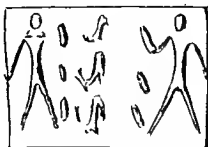
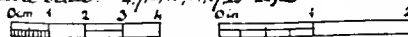

# ARROW AND JAVELIN HEADS

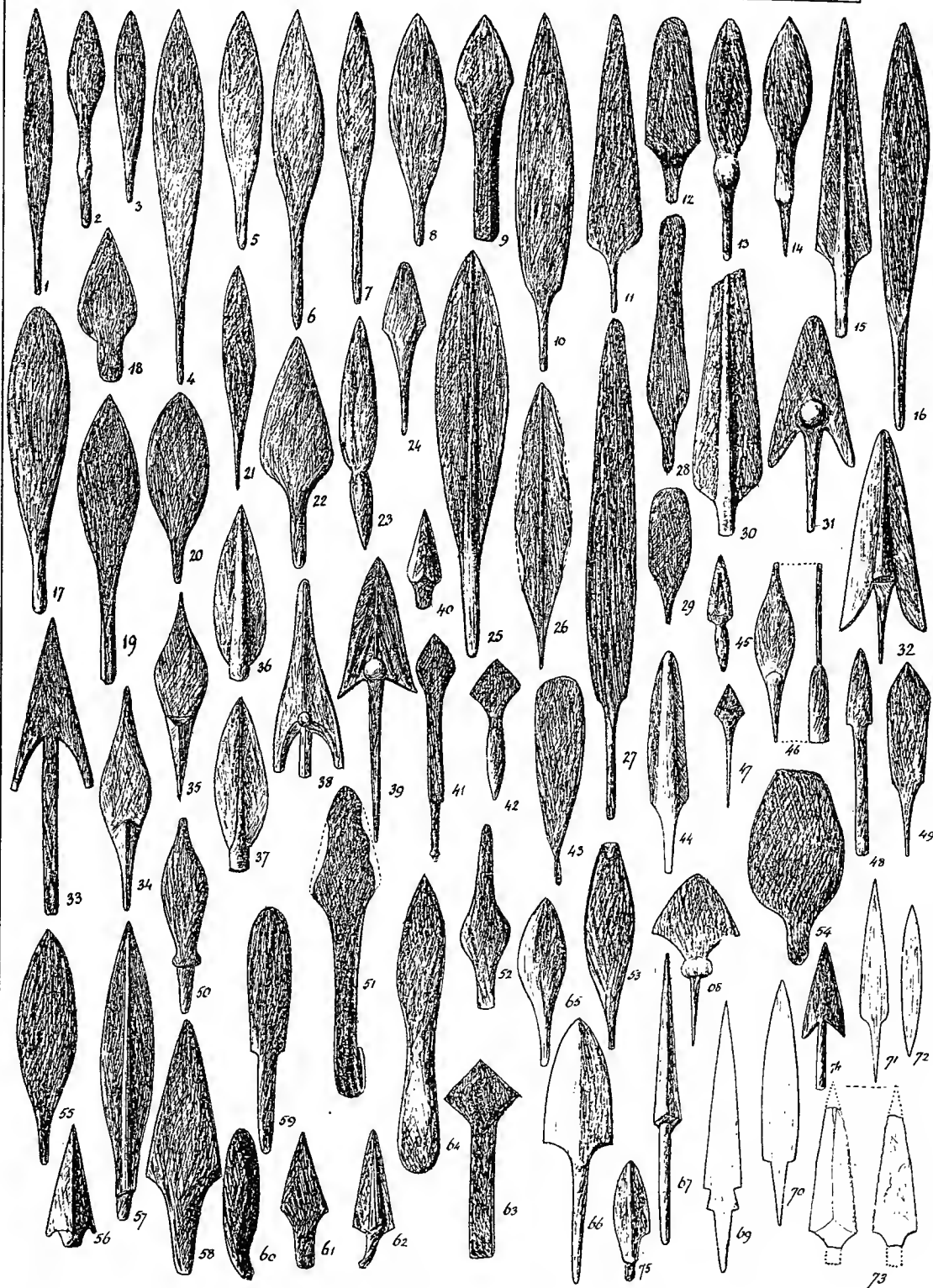
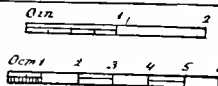





# BRONZE SPEARHEADS

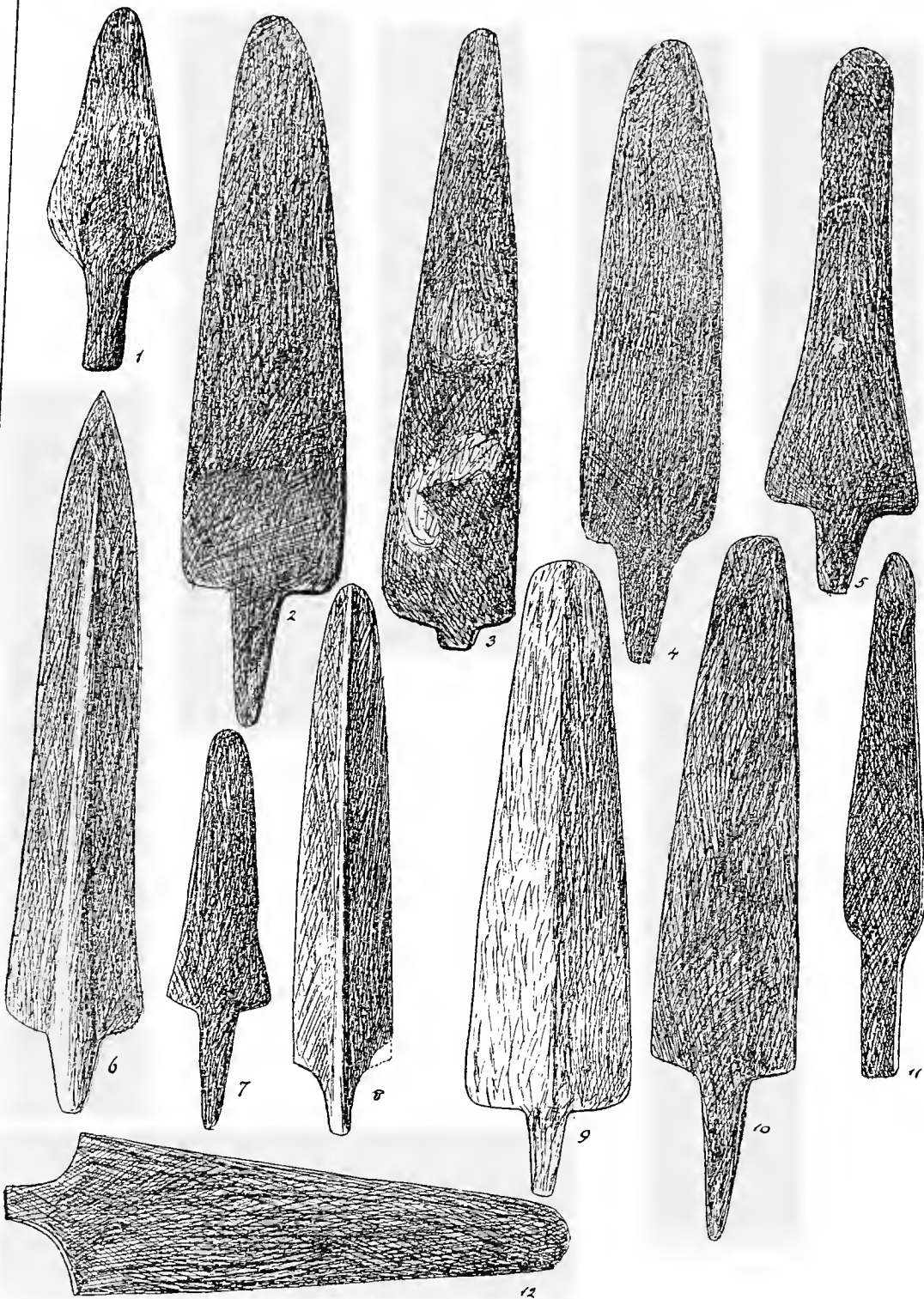
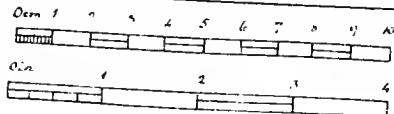

# SPEARHEADS

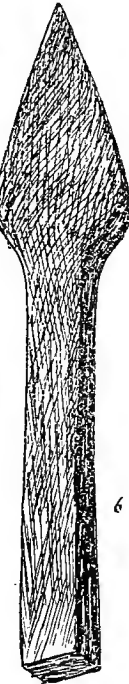
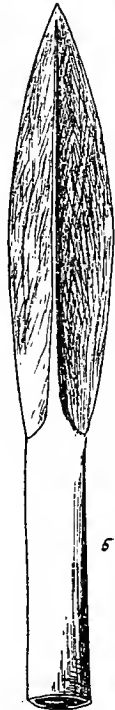
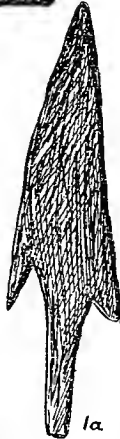
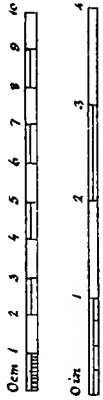







SWORDS &c.

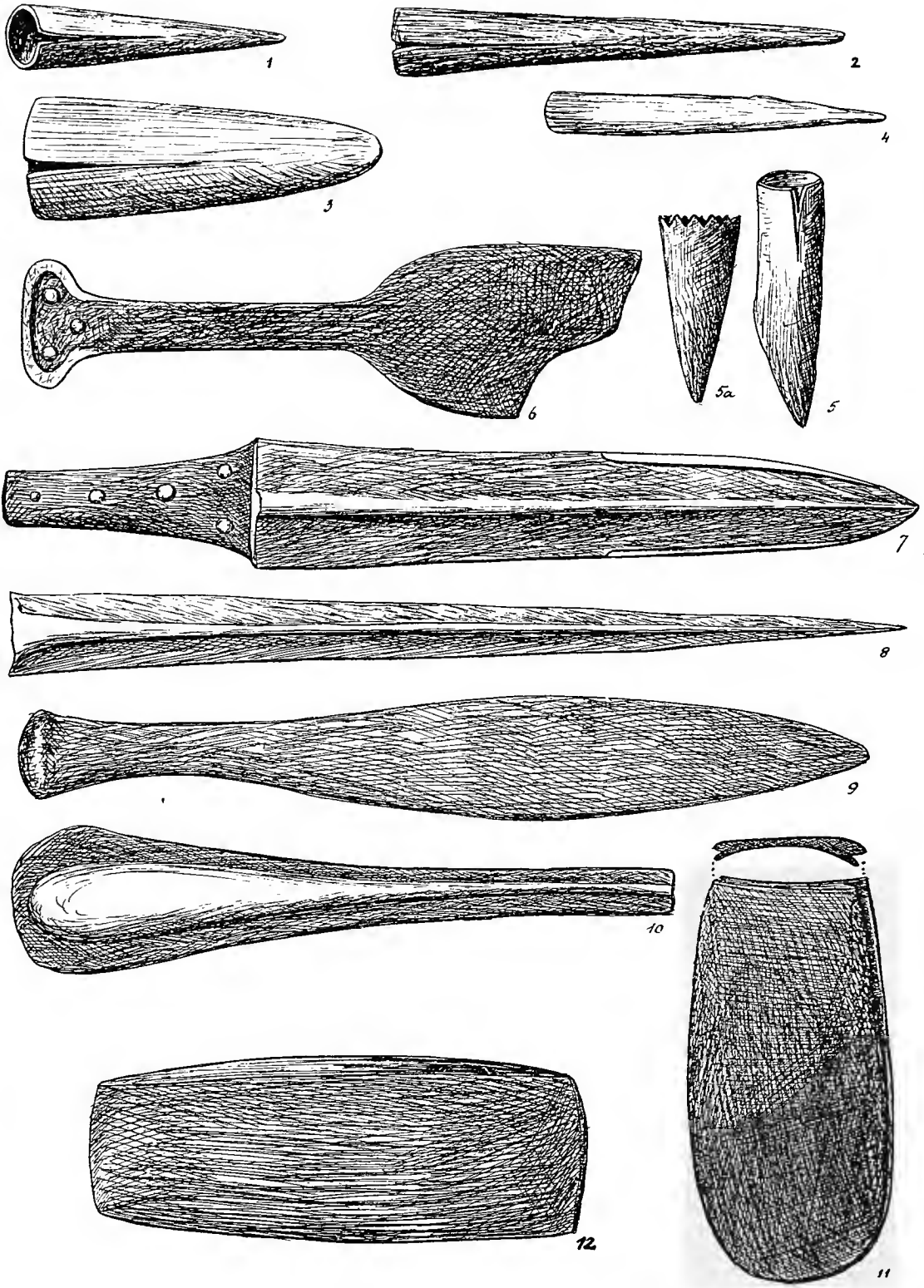

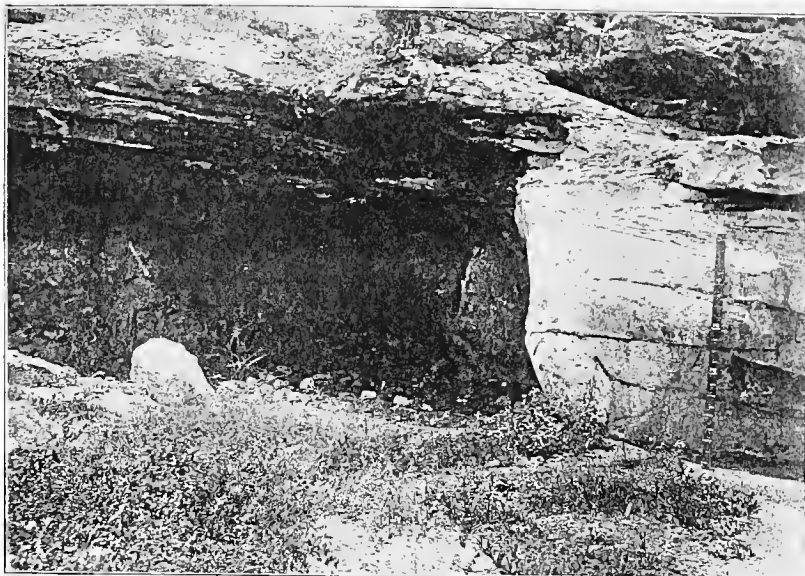

VIEW OF SHAKIF EZ-ZUTT

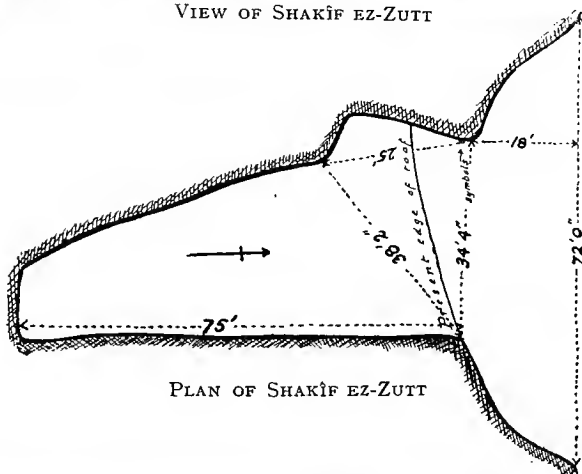

PLAN OF SHAKIF EZ-ZUTT



ROCK SURFACE AT ENTRANCE TO SHAKIF EZ-ZUTT, SHOWING CARVED SYMBOLS



# HATHOR-ASHTORETH PLAQUES

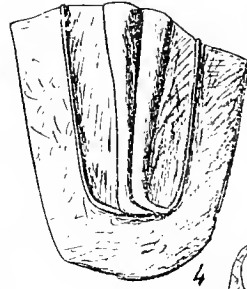
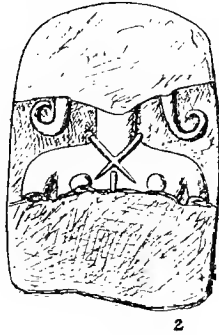
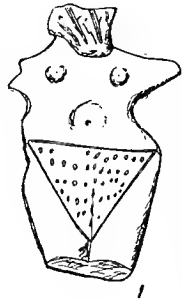

5a.



5

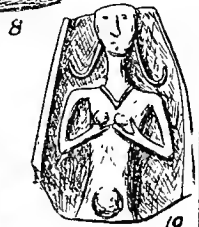
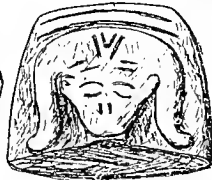
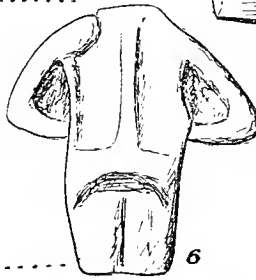
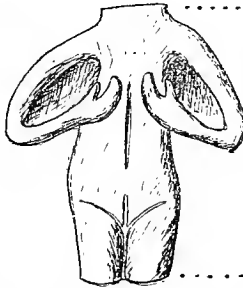

19



11



12



13



14



20

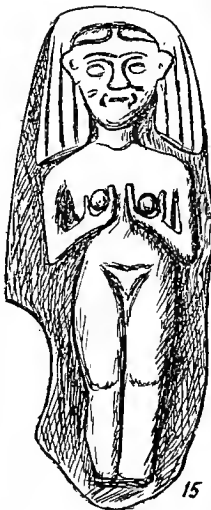

15



16



17

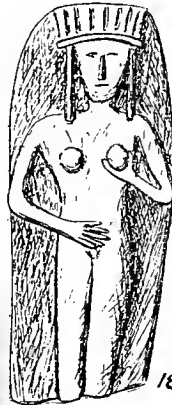

18



21

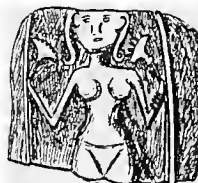

22



23





HATHOR-ASHTORETH PLAQUES, &c

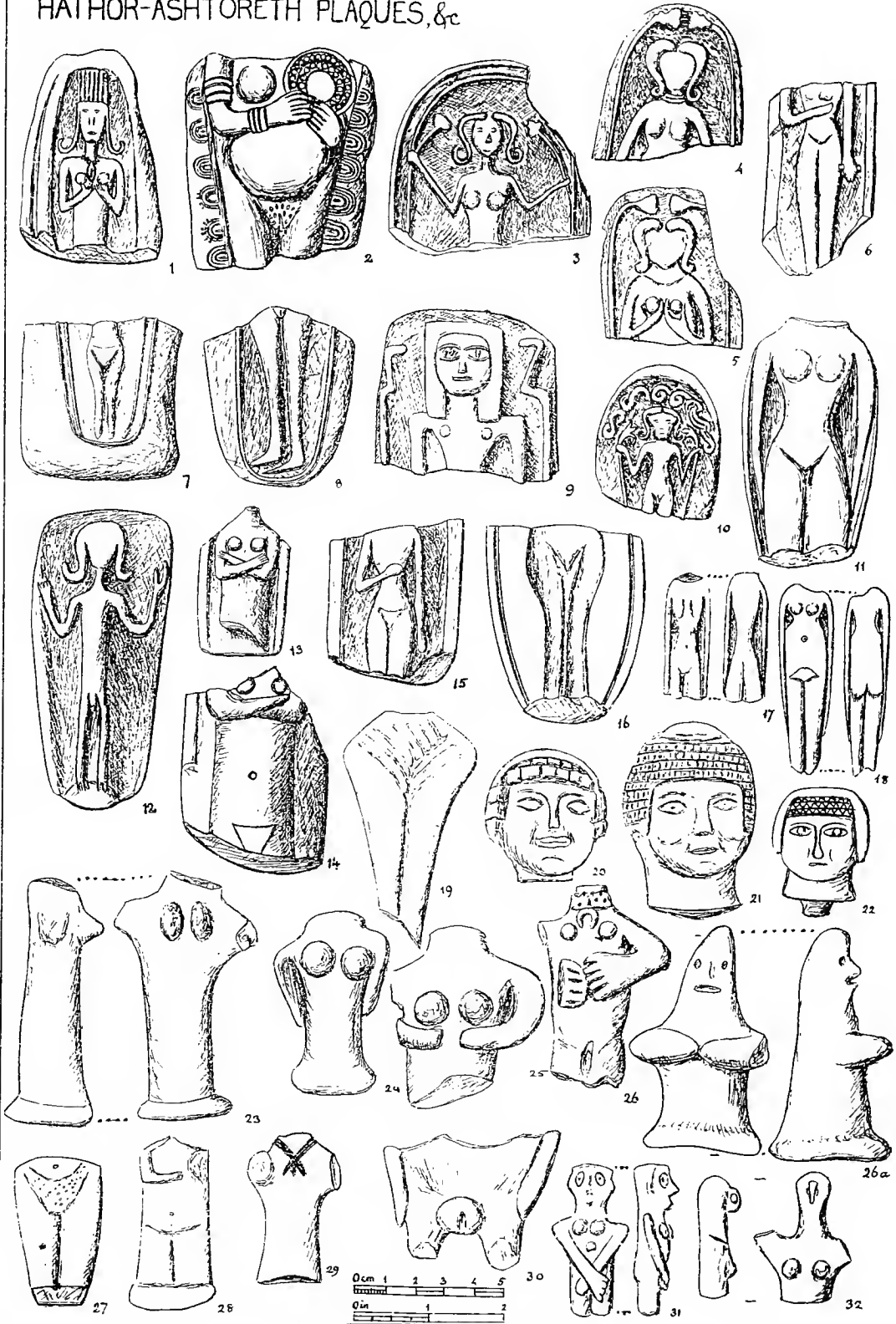



# LIMESTONE FIGURES

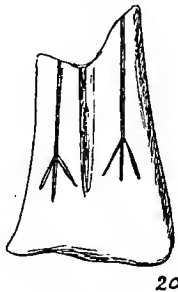
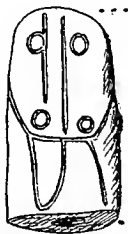
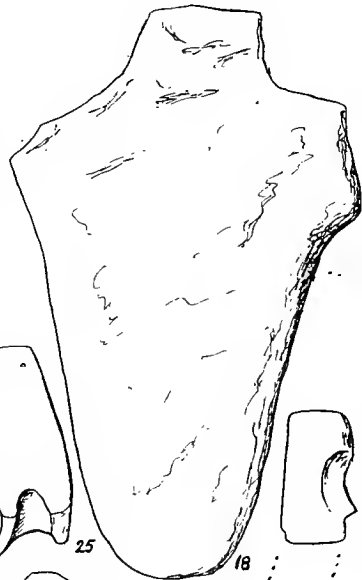
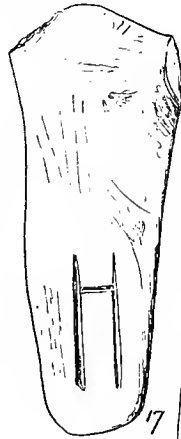
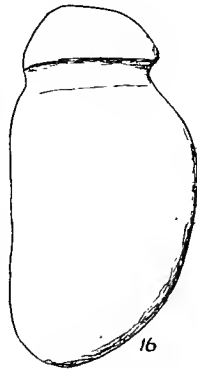
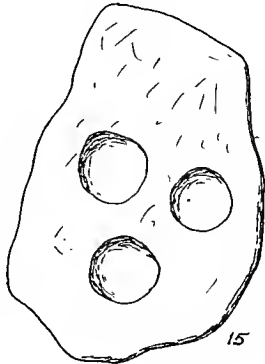
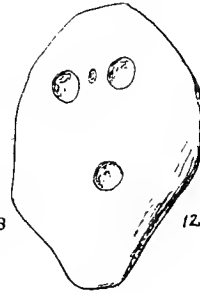
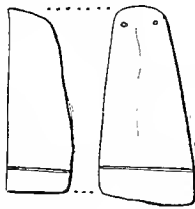
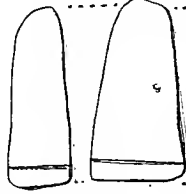
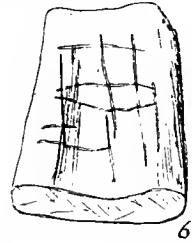
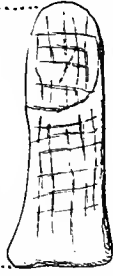
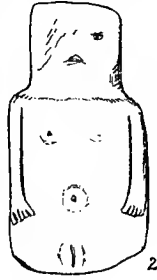
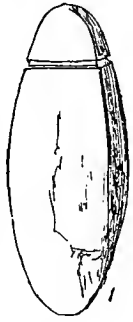
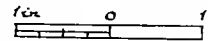
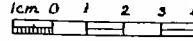







LIMESTONE FIGURES &c.

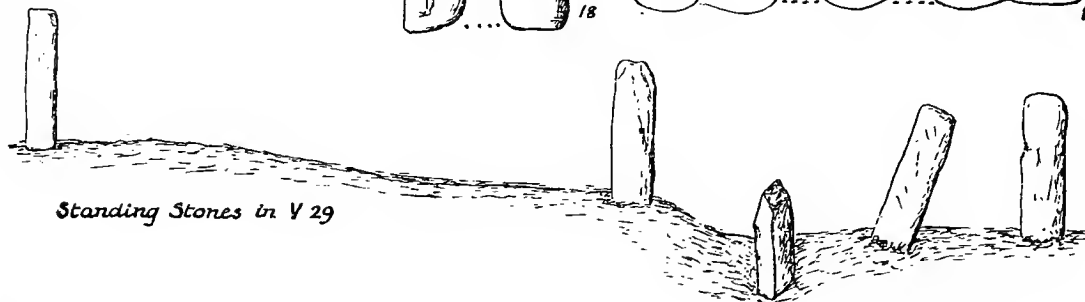
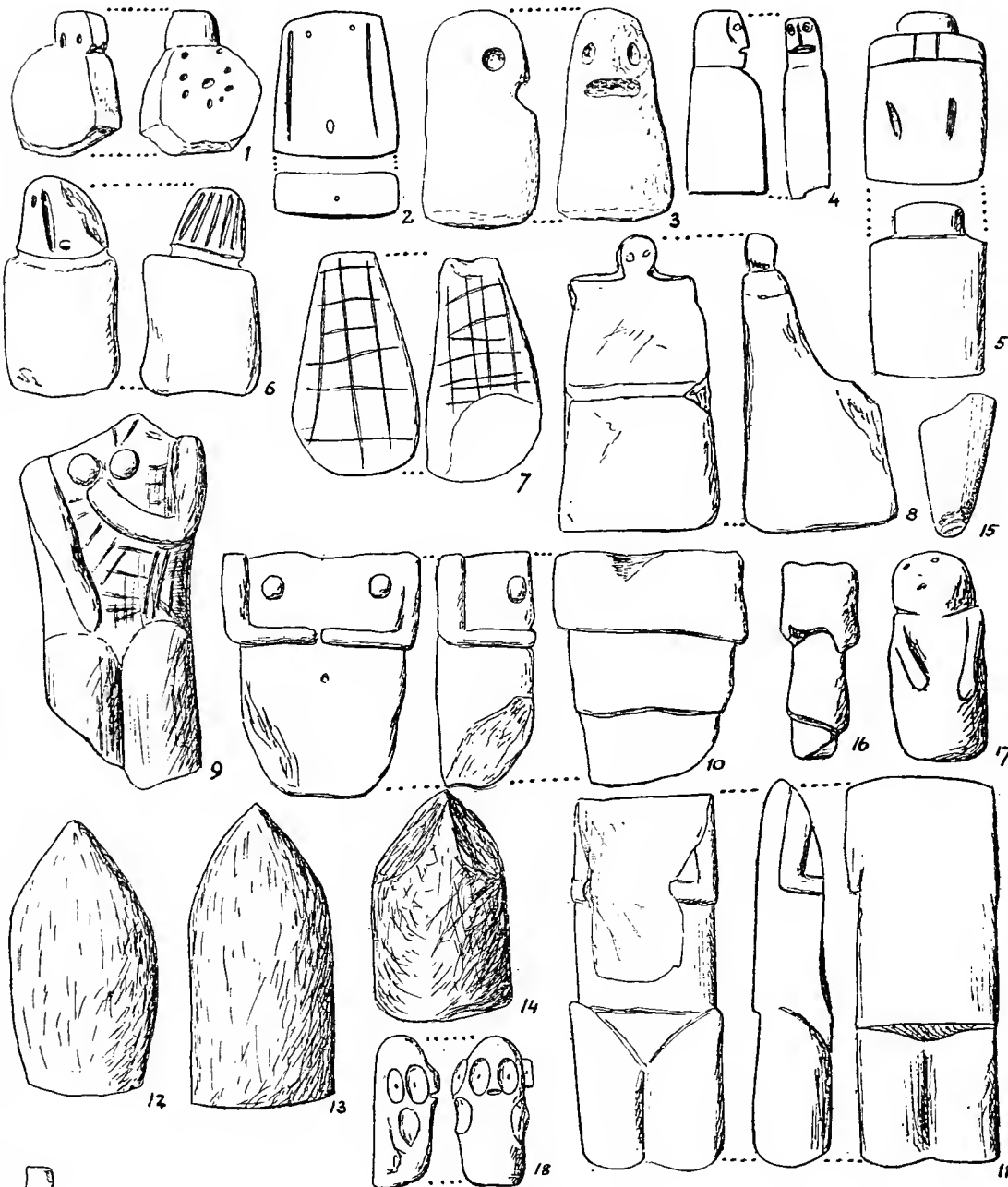
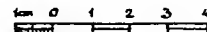
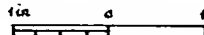

Standing Stones in V 29

# TABLES OF OFFERINGS

0cm 1 2 3 4 5

scale for figs 1,3,6,8-10

2,4,7,11 7/8 scale

0 in. 1 2

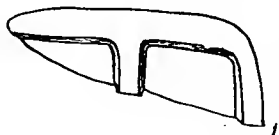

20-3 cm ( 8 in. )

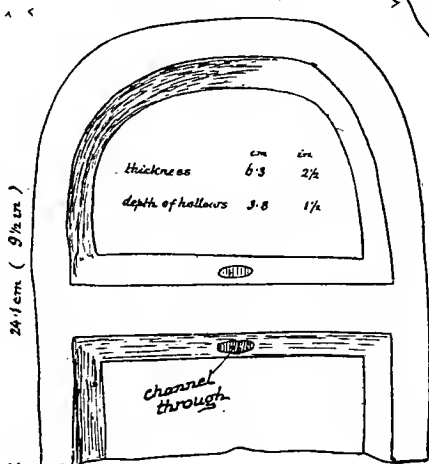
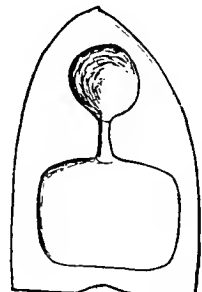
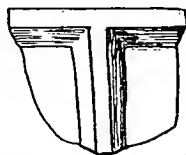
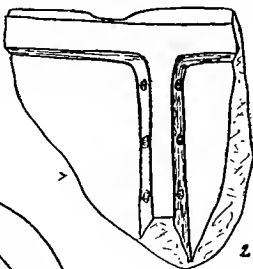

24.1 cm ( 9 1/2 in. )

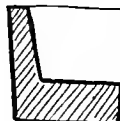

Section of 3

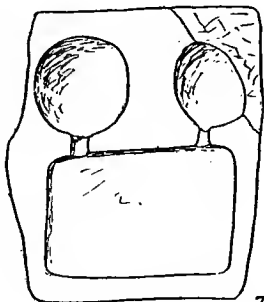
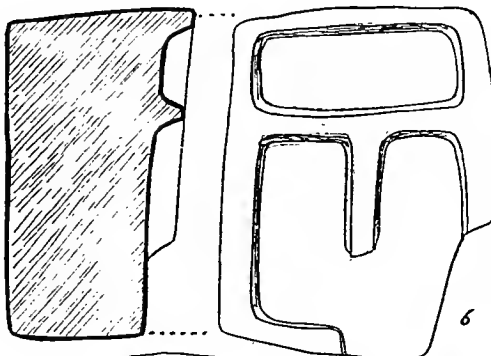

11.4 cm ( 4 1/2 in. )

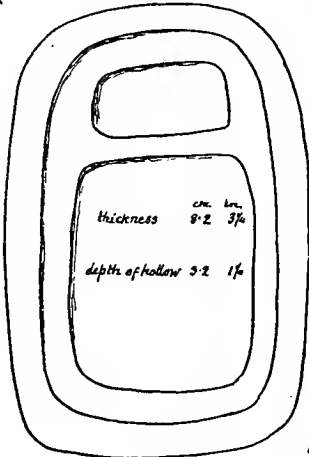
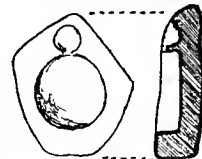
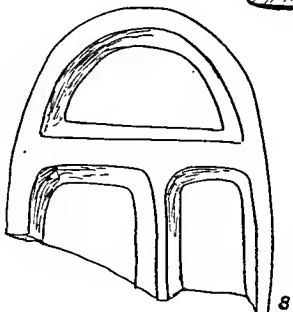

17.7 cm ( 7 in. )

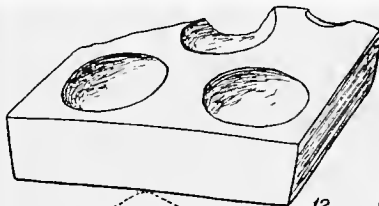

12

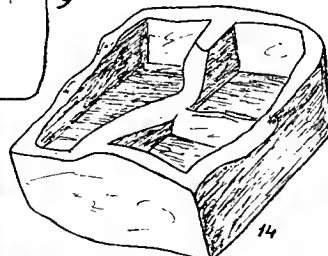

14

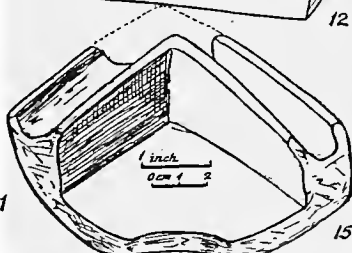

1 inch  
0cm 1 2

15

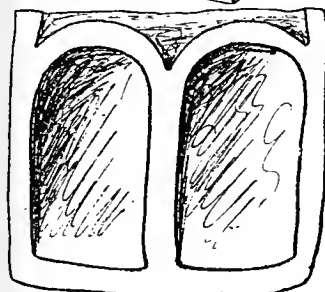

13





EX VOTO OFFERINGS &c.

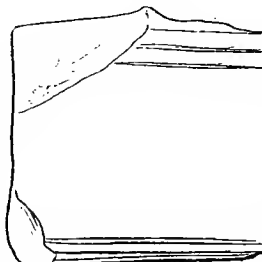
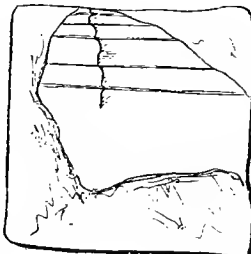
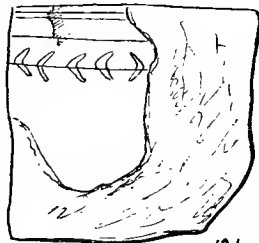
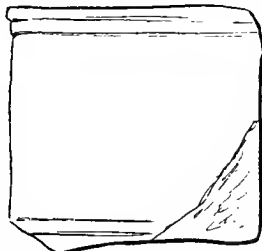
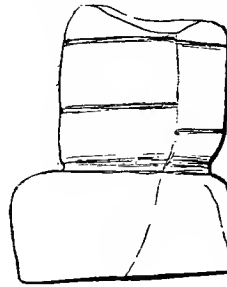
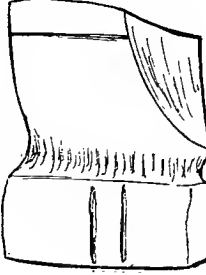
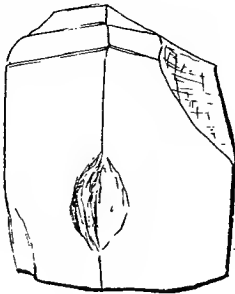
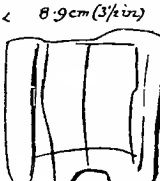
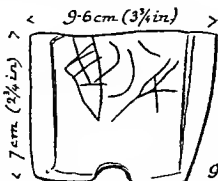
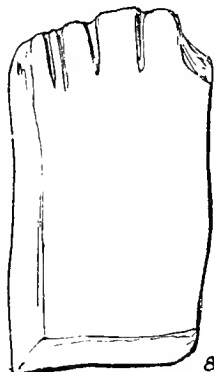
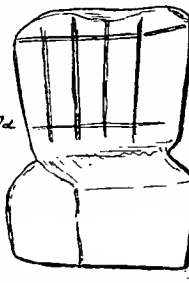
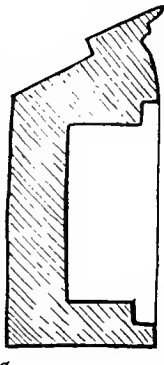
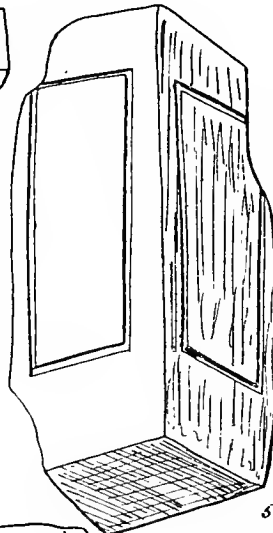
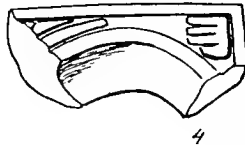
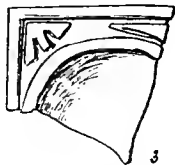
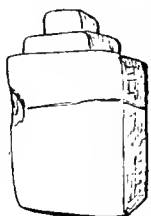
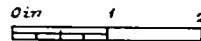
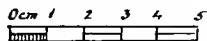

# AMULETS

